

**ROTAI**  
荣泰



# 荣泰RT-8902按摩椅维 修资料

# 目录

## CONTENTS

**Chapter 01:** Disassembly &  
Assembly Methods

**Chapter 02:** Component Schematic  
Diagrams

**Chapter 03:** Maintenance Tools & Multimeter Usage

**Chapter 04:** Troubleshooting & Repair

# 1. 按摩椅的拆装方

- ①. 小腿安装方法
- ②. 扶手拆卸方法
- ③. 头罩拆卸方法
- ④. 扶手按键板拆卸方法
- ⑤. 扶手充电板拆卸方法
- ⑥. 电控柜拆卸方法
- ⑦. 小腿底盖拆装
- ⑧. 小腿侧盖拆卸方法
- ⑨. 小腿伸缩电机拆卸方法
- ⑩. 小腿铁架拆卸方法
- ⑪. 下小腿上盖拆卸方法

# 1.1 Calf (Legrest)

## 第一步

Step 1: Install the left and right calf mounting ear sleeves/bushings.

## 第二步

Step 2: Install the 2 fixing screws for the left and right calf.

## 第三步

Step 3: Connect the calf air hose and electrical connectors/plugs.

## 第四步

Step 4: Zip up the zipper connecting the calf to the cape/cover.

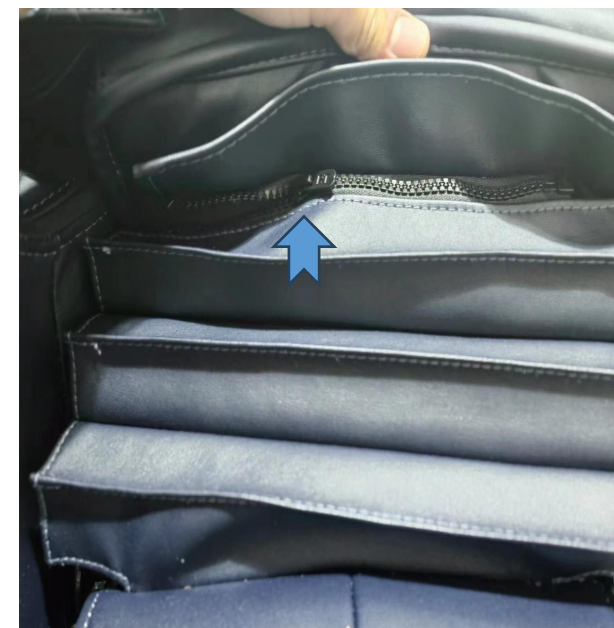
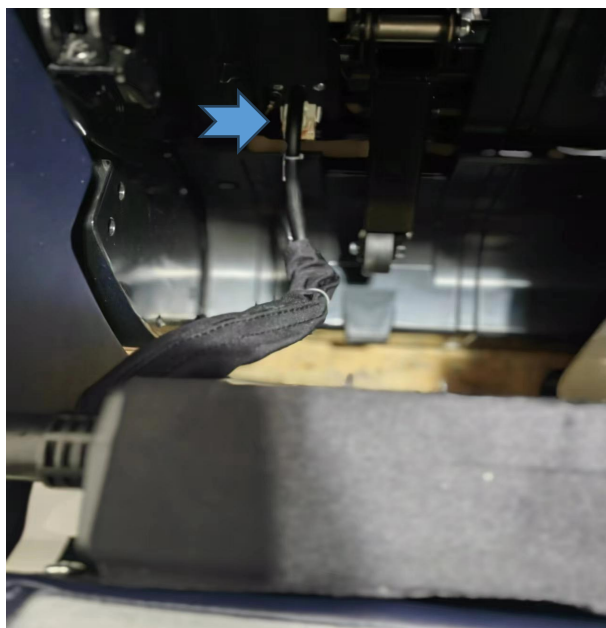

# 1.2 Armrest Disassembly

## 第一步

Step 1: Unplug connectors and air hoses. Remove the fixing screw at the front of the armrest.

## 第二步

Note: During installation, the iron bracket on the armrest must slot into the host's catch/groove.

## 第三步

Step 2 & 3: (Images showing removal process).

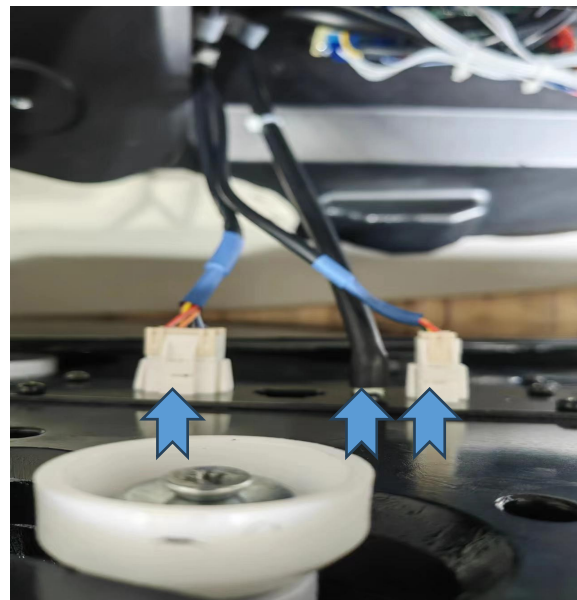

# 1.3 Head Hood/Cover Disassembly

## 第一步

Step 1: Remove the screws marked on the rear cover.



## 第二步

Step 2: Unzip the shoulder airbag leather zipper.

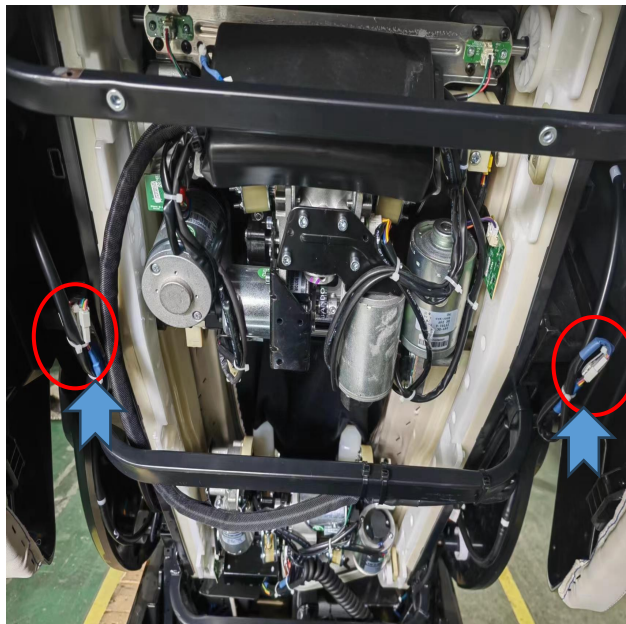

## 第三步

Step 3: Cut the cable ties and unplug the connectors.



## 第四步

Step 4: Remove the screws marked on the shoulder area and remove the head hood.



# 1.4 Armrest Keypad (Control Panel) Disassembly

## 第一步

Step 1: Lift/Open the armrest keypad.

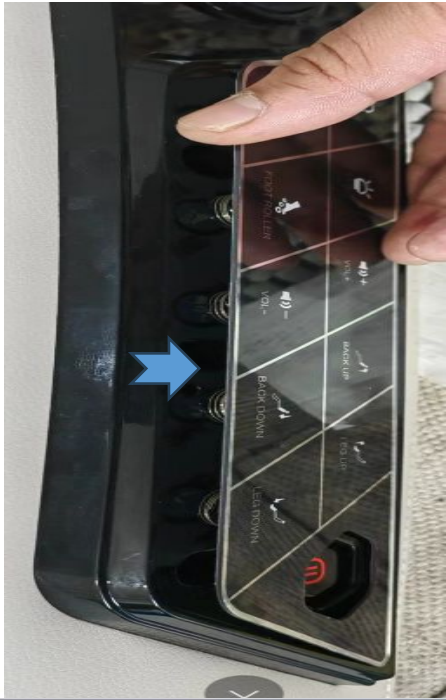

## 第二步

Step 2: Remove the marked screws.



## 第三步

Step 3: Remove the screws marked on the keypad plastic casing.



## 第四步

Step 4: Unplug the armrest keypad connector.



# 1.5 Armrest Motor Disassembly

## 第一步

Step 1: Unzip the armrest leather cover zipper.

## 第二步

Step 2: Remove the 2 marked screws.

## 第三步

Step 3: Remove the 4 marked screws on the sensor board.

## 第四步

Step 4: Unplug the marked connector.

## 第五步

Step 5: Remove the 3 marked screws on the armrest iron frame.

## 第六步

Step 6: Remove the staples/nails from the leather cover.

## 第七步

Step 7: Remove the 4 marked screws on the outer cover.

## 第八步

Step 8: Remove the motor.



# 1.6 Power Box Cover Disassembly

## 第一步

**Step 1:** Remove the 3 marked screws and the 2 marked screws.



## 第二步

取下标记的3颗螺丝



# 1.7 Calf (Legrest) Bottom Cover Disassembly

## 第一步

Step 1: Remove the 2 fixing screws on the calf bottom cover.



## 第二步

Step 2: Remove the calf bottom cover decoration piece.



## 第三步

Step 3: Unplug the calf bottom cover anti-pinch connector.



## 第四步

Step 4: Remove the 4 fixing screws on the calf bottom cover.



# 1.8 Calf Side Cover Disassembly

## 第一步

Step 1:  
Remove the 4 fixing screws on the calf side cover.

## 第二步

Step 2:  
Remove the calf wheel protection cover.

## 第三步

Step 3:  
Remove the 8 fixing screws on the calf rear cover.

## 第四步

Step 4:  
Remove the calf wheel fixing screw.

## 第五步

Step 5:  
Remove the calf side cover fixing screw.

## 第六步

Step 6:  
Unplug the calf anti-pinch connector.

## 第七步

Step 7:  
Remove the calf side cover cable guard. Pull the calf wire harness out through the side cover hole.

## 第八步

把小腿线束从侧盖孔中取出

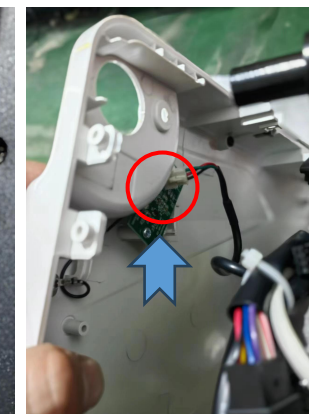
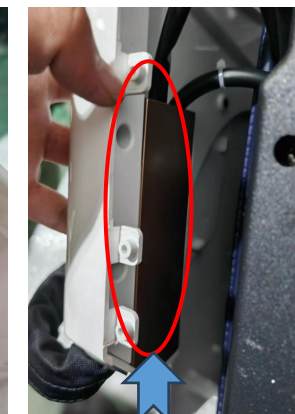
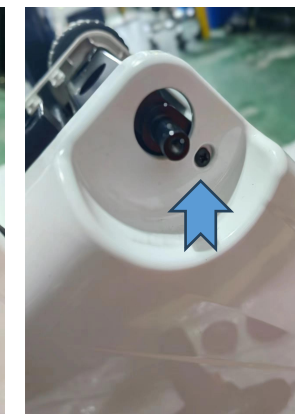
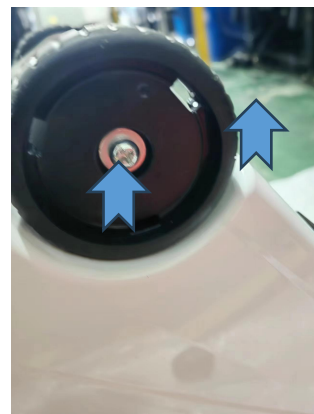
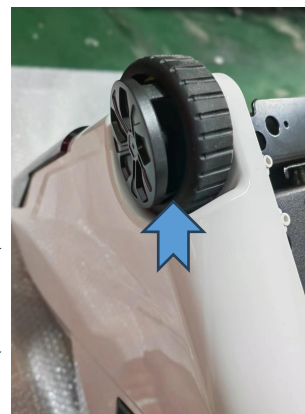
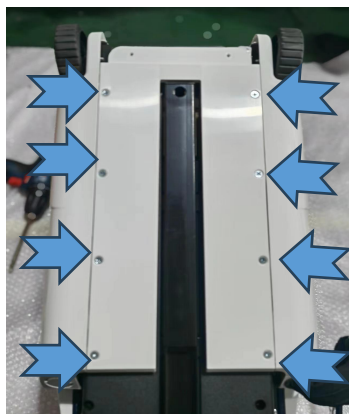
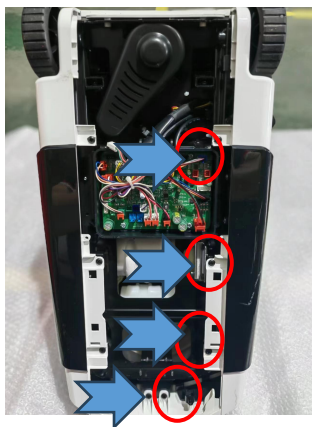

# 1.9 Calf Extension Motor Disassembly

## 第一步

取下小腿伸缩电机保护盖4颗固定螺丝



## 第二步

掉扎带，拔掉伸缩电机插件

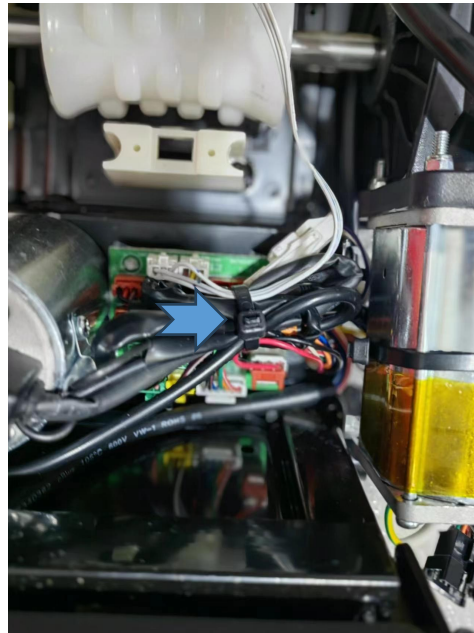

## 第三步

取下伸缩皮带



## 第四步

取下伸缩电机4颗固定螺丝

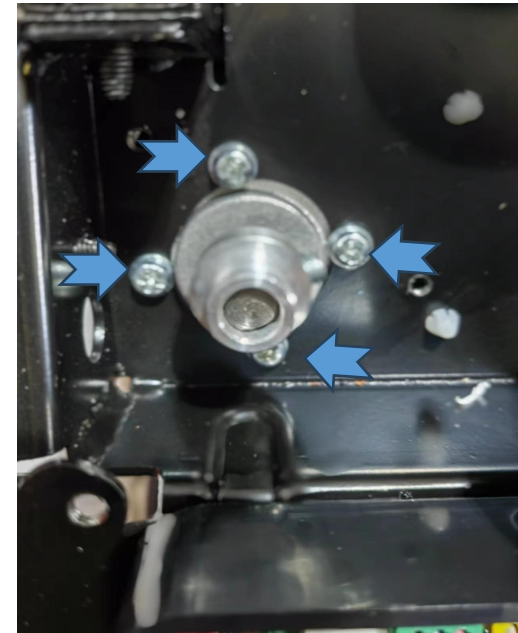

# 1.10 Calf Iron Frame Disassembly

## 第一步

**Step 1:** Cut cable ties, unplug air hoses and connectors (as shown in Figure 1)



## 第二步

**Step 2:** Remove the 4 connecting screws between the calf iron frame and the upper calf (as shown in Figure 2)

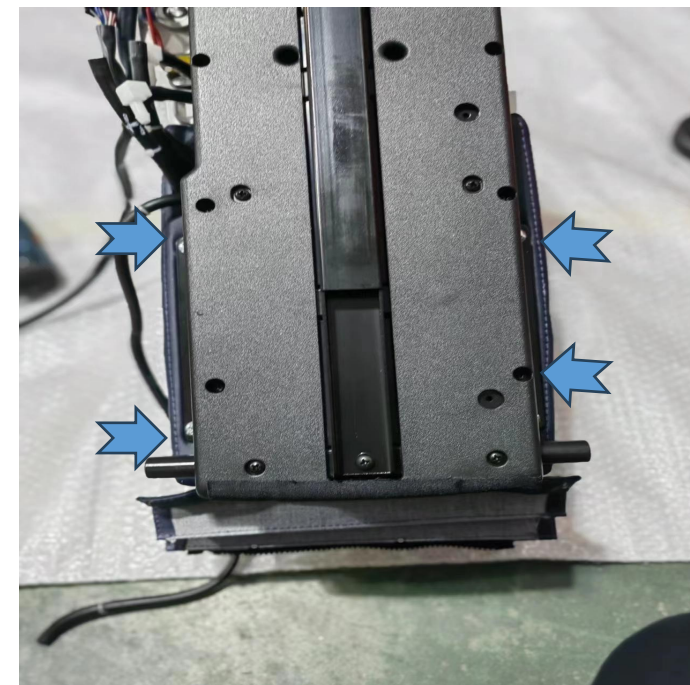

# 1.11 Lower Calf Upper Cover Disassembly

## 第一步

**Step 1:** Remove the 4 fixing screws between the iron frame and plastic parts.

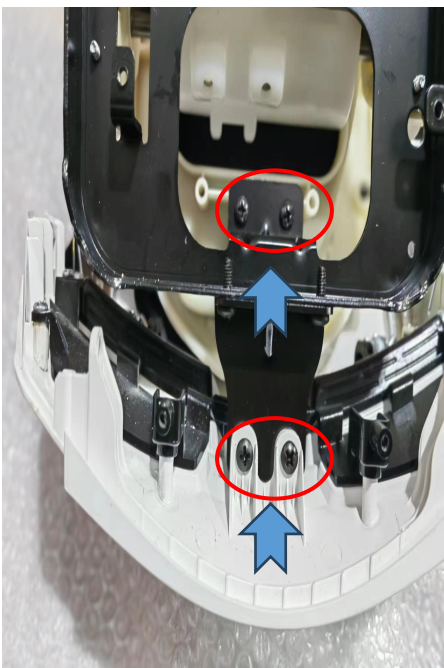

## 第二步

**Step 2:** Move the lower calf plastic part aside and unplug the connector.



## 第三步

**Step 3:** Remove the 8 fixing screws between the calf inner liner and the lower calf upper cover.



## 第四步

**Step 4:** Remove the 9 fixing screws between the lower calf front cover and upper cover. Then remove the 12 fixing screws on the lower calf front cover.

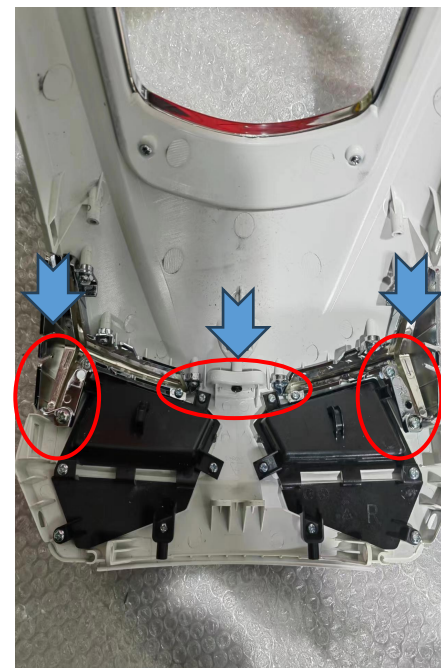

## 第四步



Inputs/Power: DC24V Input ,  
5V Power Supply.

Actuators (Linear Motors): Right Calf Push  
Rod , Zero Gravity Push Rod , Front Slide  
Push Rod , Left Calf Push Rod , Backrest Push  
Rod (White).

Sensors/Counters (Positioning): Front Slide Count  
, Zero Gravity Count , Left Calf Count , Backrest  
Count , Right Calf Count.

Safety (Anti-Pinch): Left Foot Cover  
Anti-pinch , Right Foot Cover Anti-pinch ,  
Rear Foot Cover Anti-pinch , Calf Rear  
Anti-pinch.

Communication/Other: Left Armrest 24V , Cape Heating DC24V , Right  
Side Air Valve , Left Side Air Valve , Right Armrest/Calf Comm ,  
APP Comm , 5V Comm , Voice Signal , Cape Heating NTC (Temp Sensor)  
, Air Pump Comm , Mainboard Comm , Left Armrest/Calf Comm ,  
Mechanism Comm.

⑥. 左右扶手控制板

⑦. 上下机芯宽中窄板, 3D限位  
/计数板示意图

⑧. 脚底转接板, 机芯行程板, 压杆感应板

⑨. 彩灯转接板机, 芯行程限位板, 压杆感应板  
插件示意图

⑩. 电源整流板示意图

⑪. 蓝牙板, 5V电源板示意图

⑫. 扶手信号转接板, 心电检测板示意图

⑬. 上机芯示意图

⑭. 下机芯示意图

## 2.2 Mainboard Connector Distribution

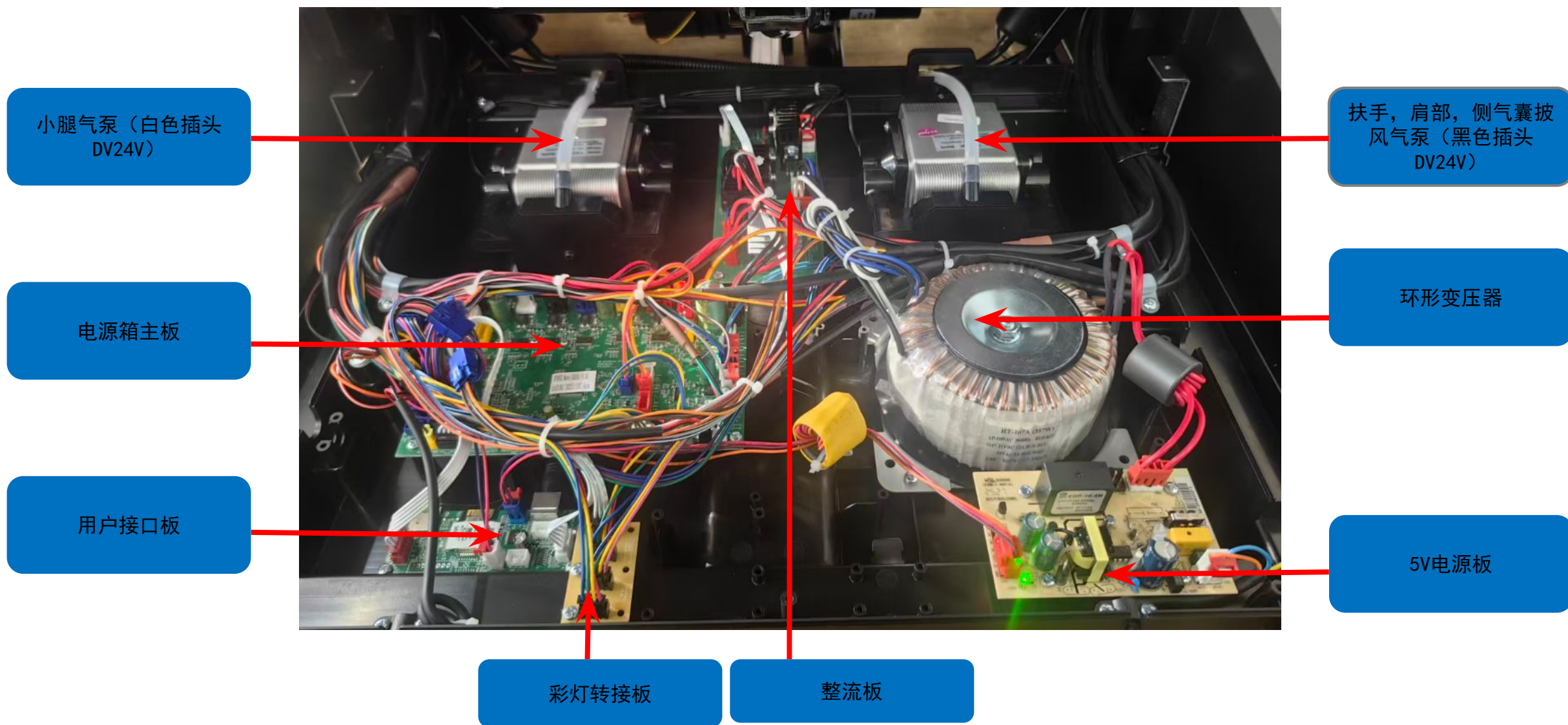

## 2.2 Mainboard Connector Distribution

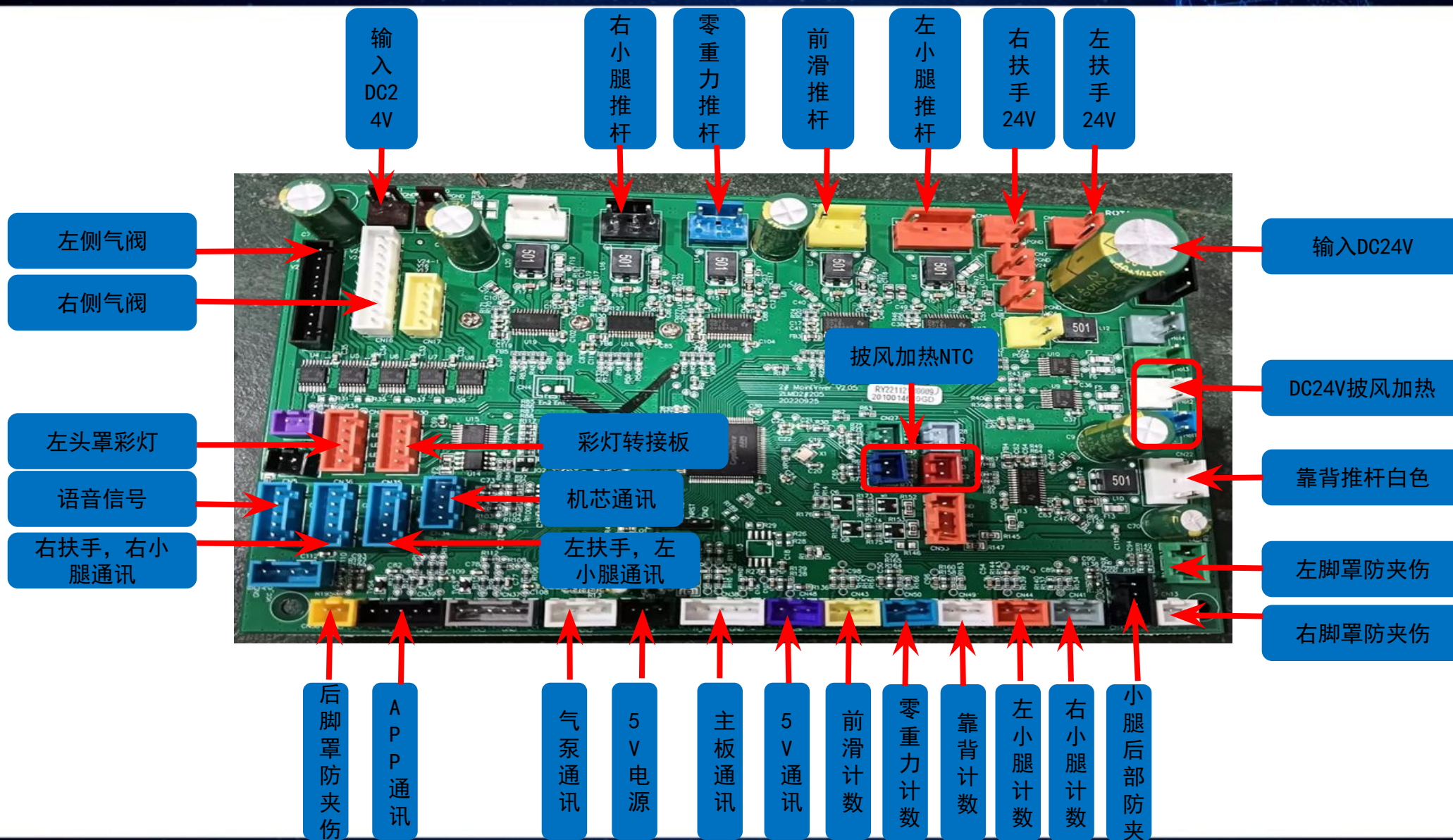

## 2.3 Upper Core (Mechanism) Diagram

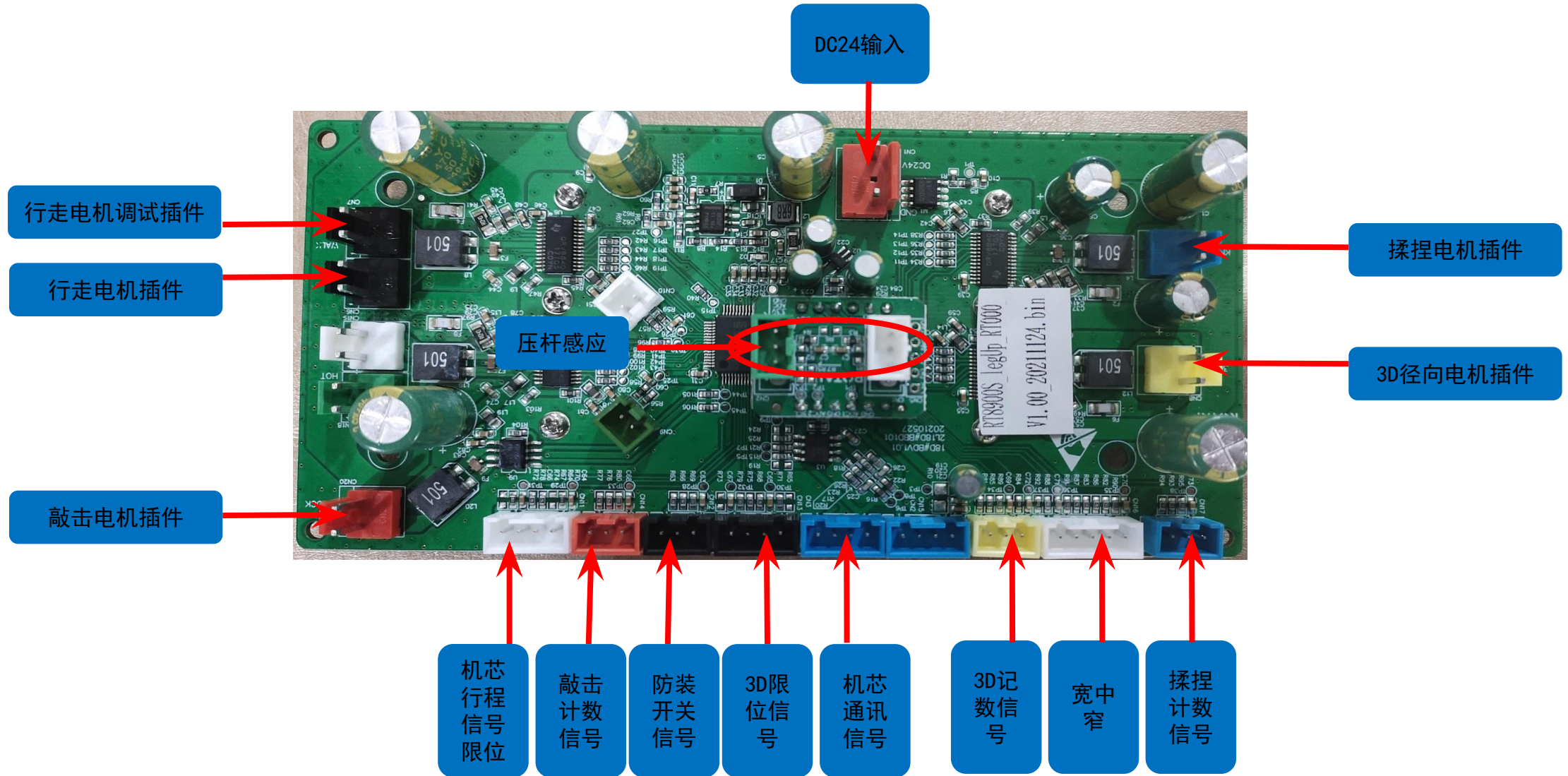

## 2.4 Lower Core (Leg) Diagram

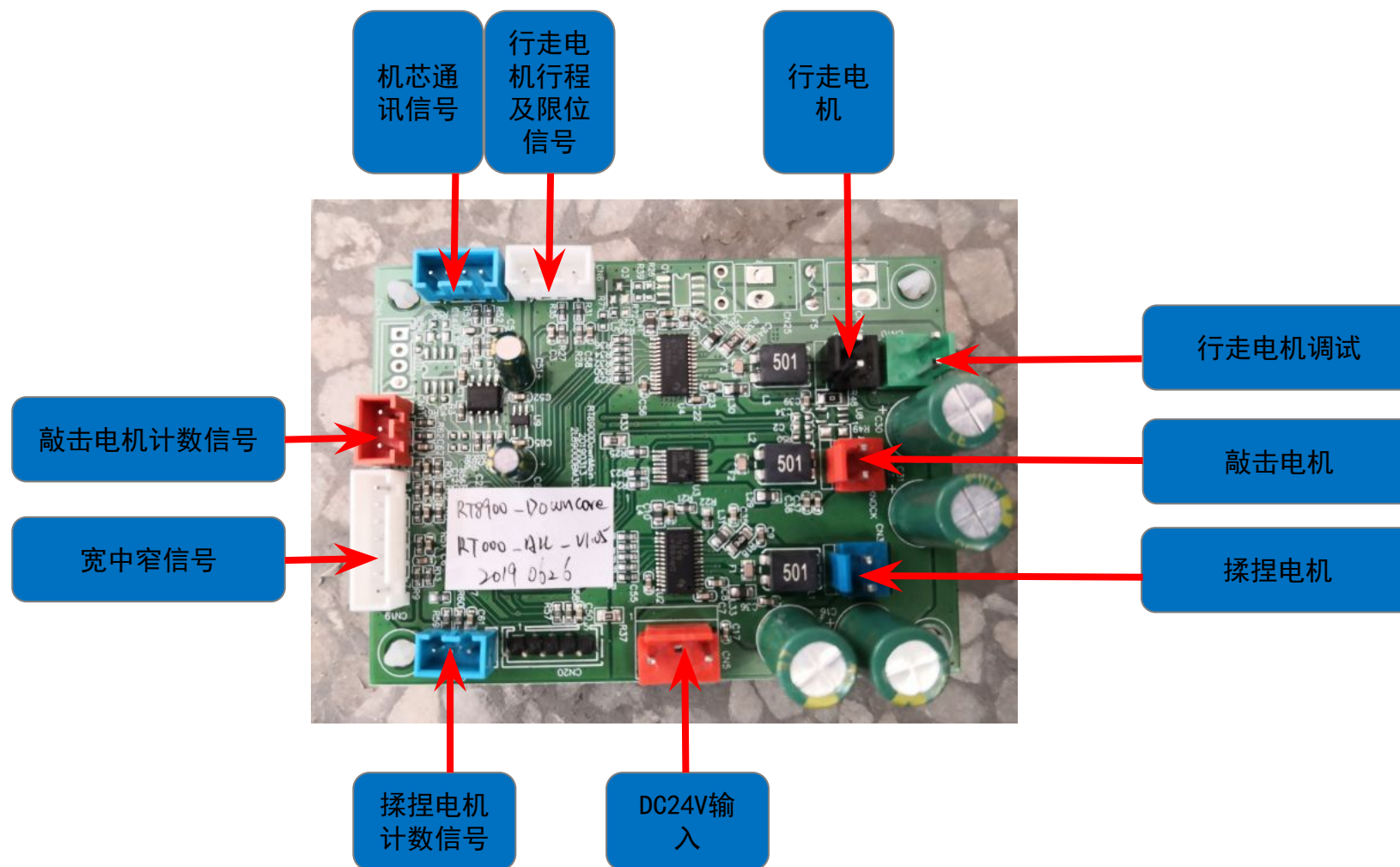

## 2.5左右小腿主板插件示意图

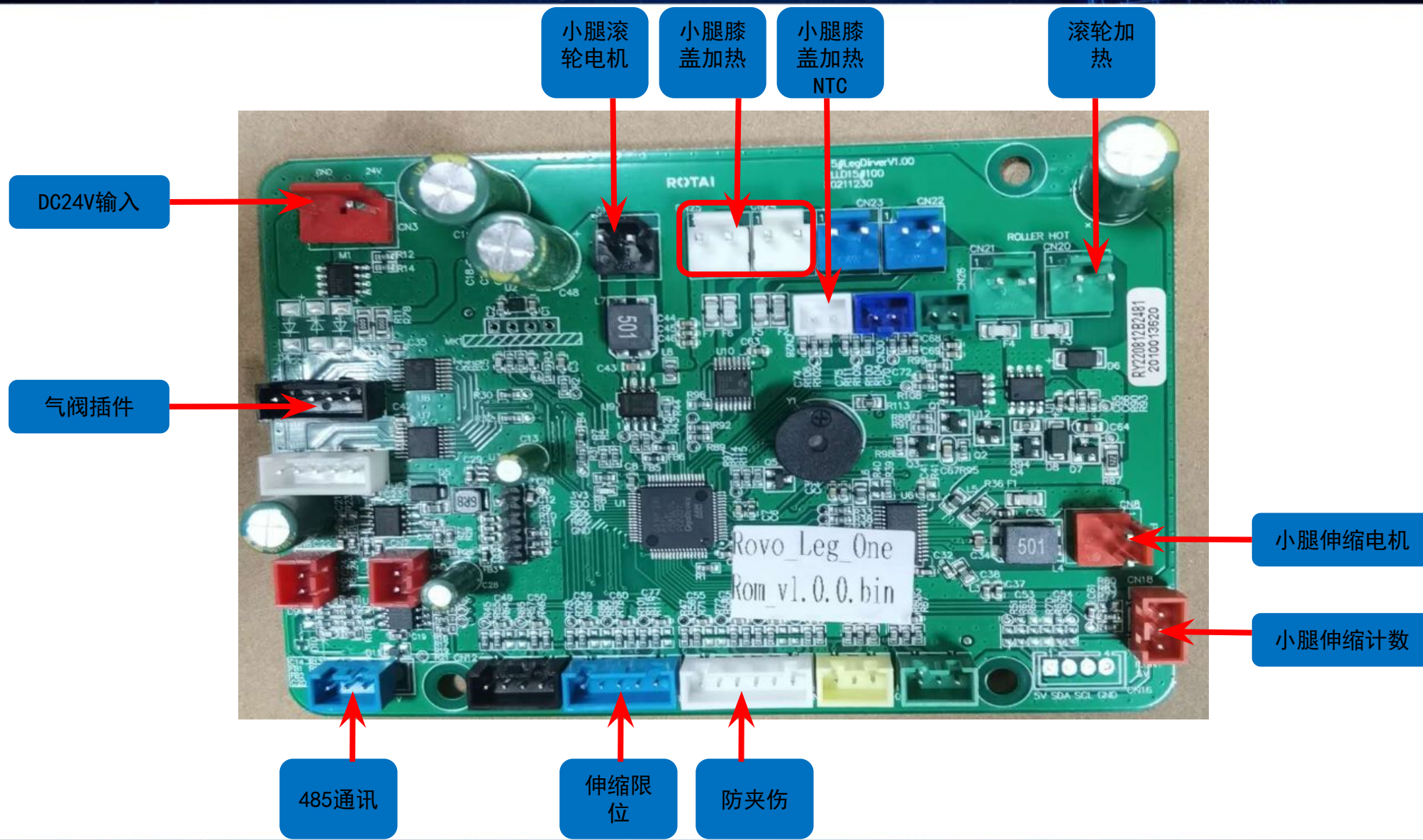

## 2.6 Armrest Control Board: Armrest Motor , 485 Comm , Air Valve , 24V Input , 24V Charging.



扶手电机

485通讯输入

扶手气阀插件

DC24V输入

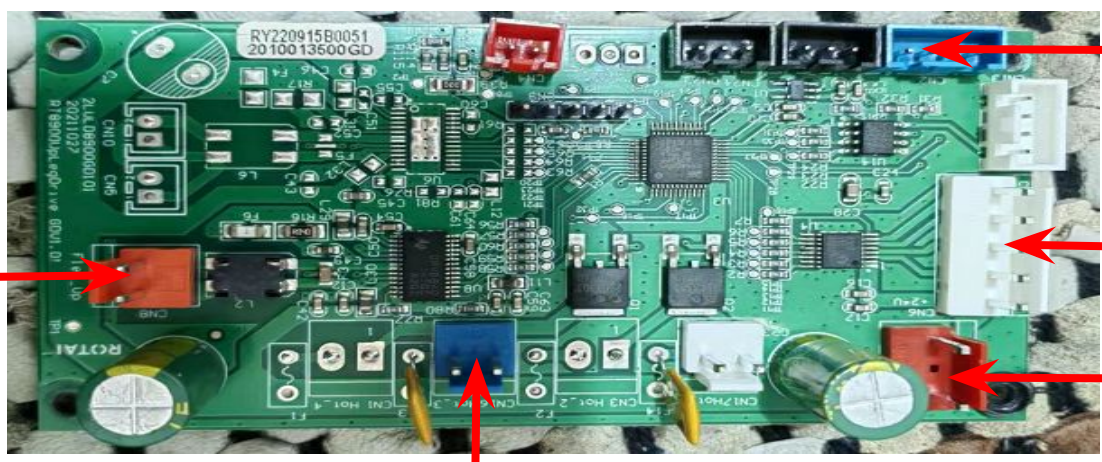

扶手电机

485通讯输入

扶手气阀插件

DC24V输入

DC24V充电

## 2.7 上下机芯宽中窄板, 3D限位板, 3D计数板示意图

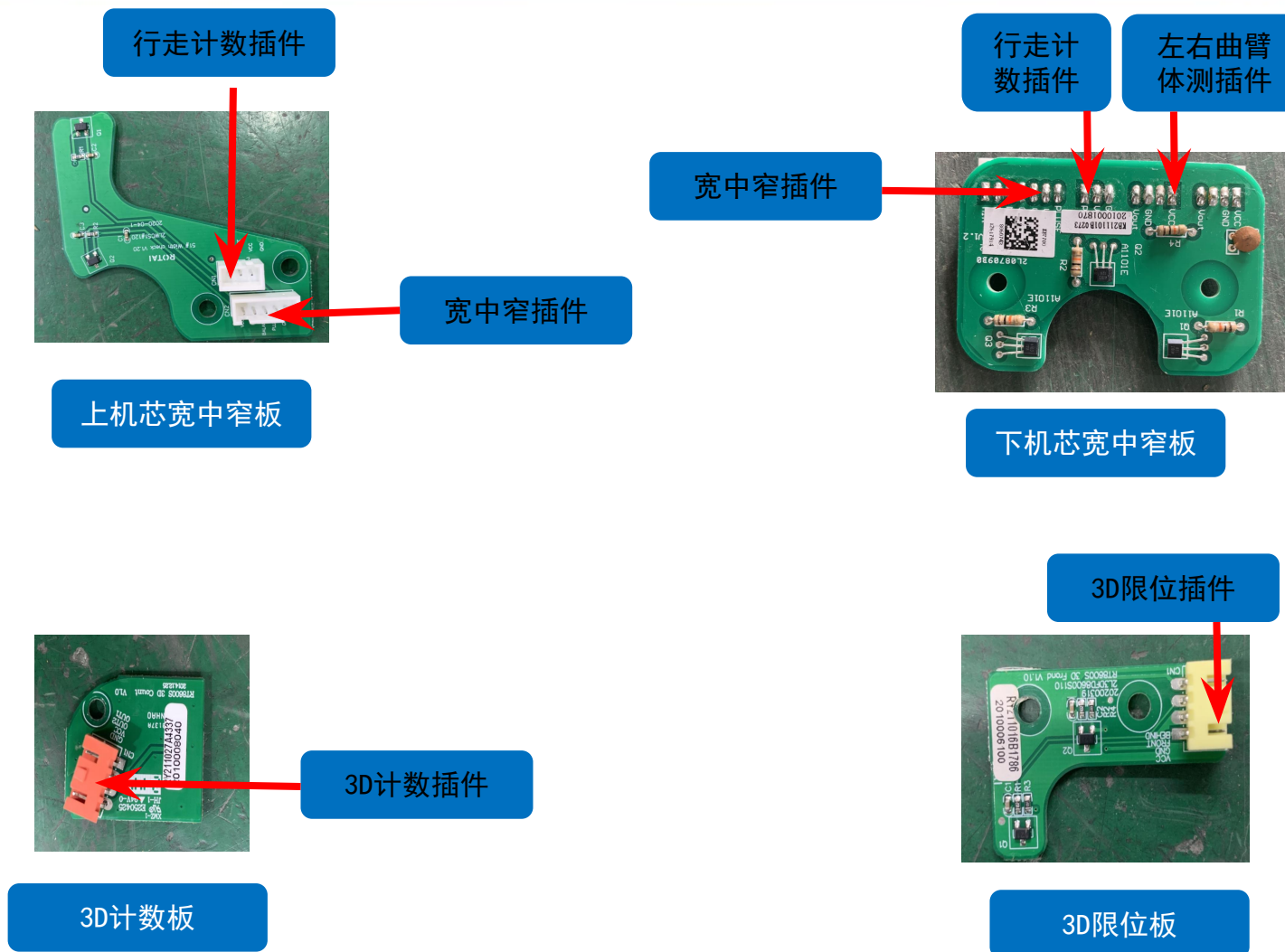

## 2. 8脚底转接板, 机芯行程限位板, 压杆感应板示意图

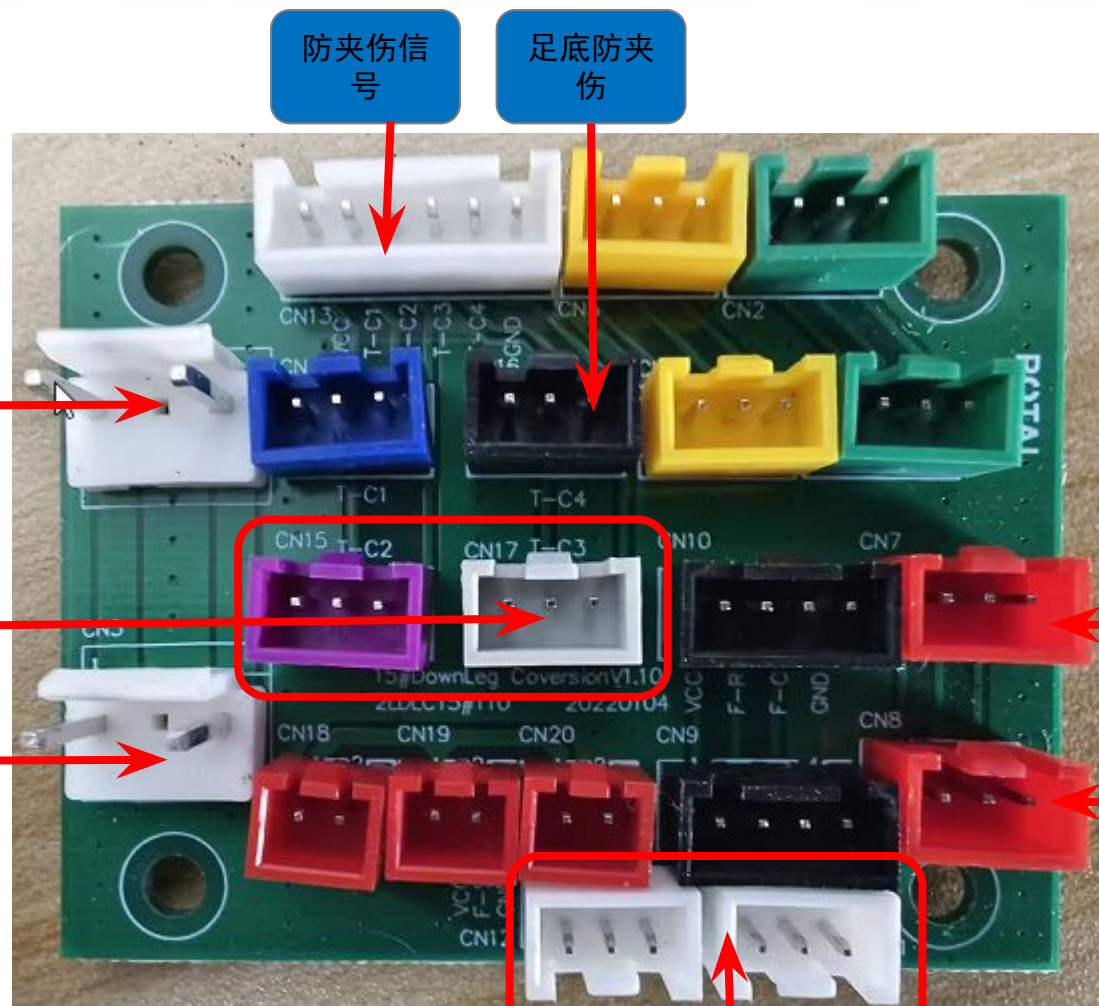

上机芯行程限位板插件



上机芯行程限位板

下机芯行程限位板插件

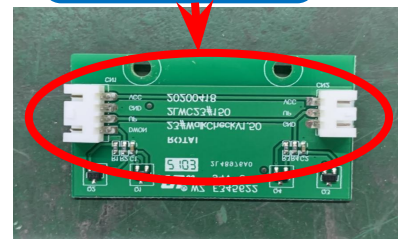

下机芯行程限位板

压杆感应插件



压杆感应插件

## 2.9 Light Adapter Board: Left Armrest Light , Mainboard Comm , Right Armrest Light , Right Head Hood Light.

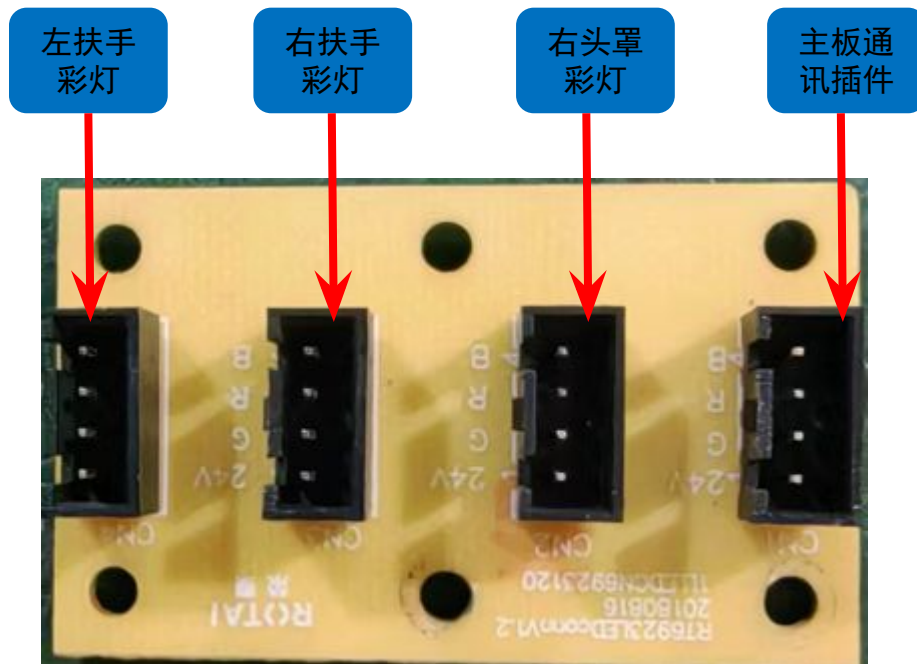

上机芯行程限位板插件



上机芯行程限位板

下机芯行程限位板插件

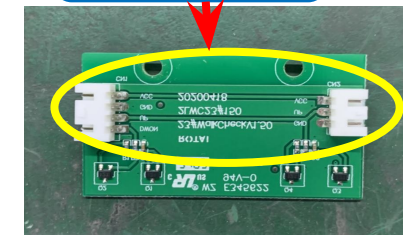

下机芯行程限位板

压杆感应插件



压杆感应插件

2.10 Power Rectifier Board: DC24V Mainboard , Calf Air Pump , Host Air Pump , Transformer Plugs , DC24V Mechanism , Air Pump Comm , Mainboard Valve 24V ,

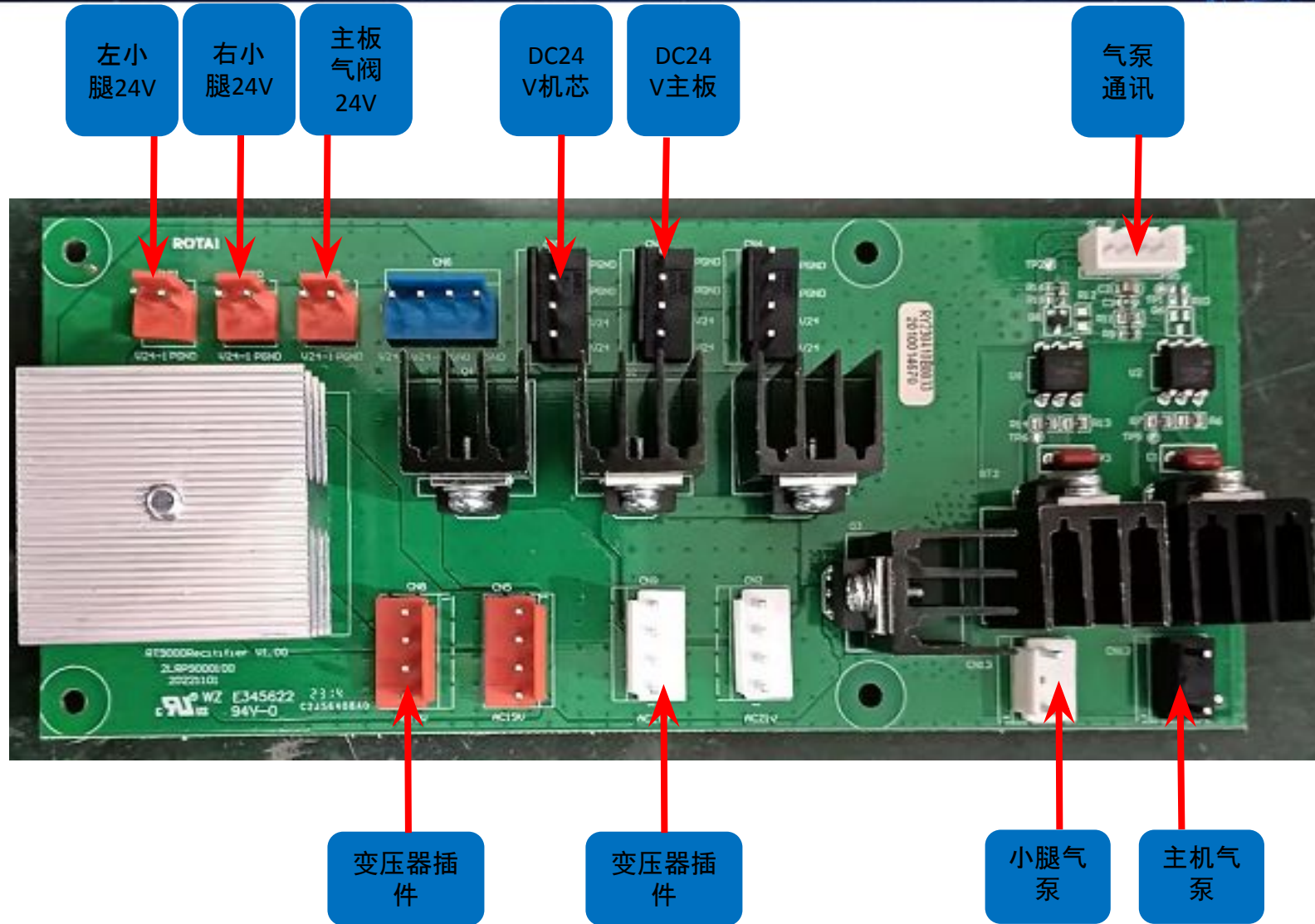

2.11 Bluetooth Board: APP Signal , Remote Socket , Left/Right Speaker. 5V Power Board: AC220V Input , 5V Output , AC220V Output.

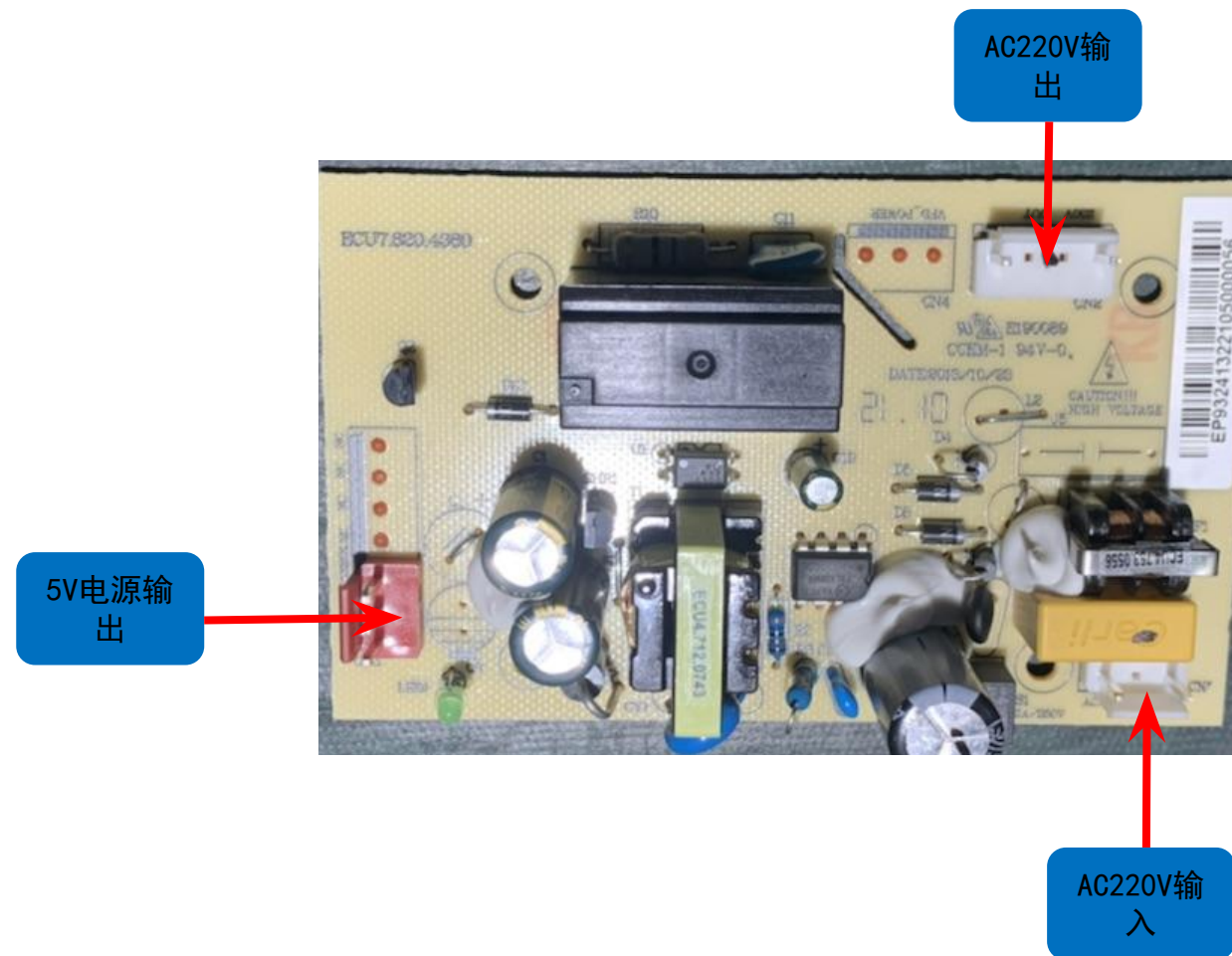
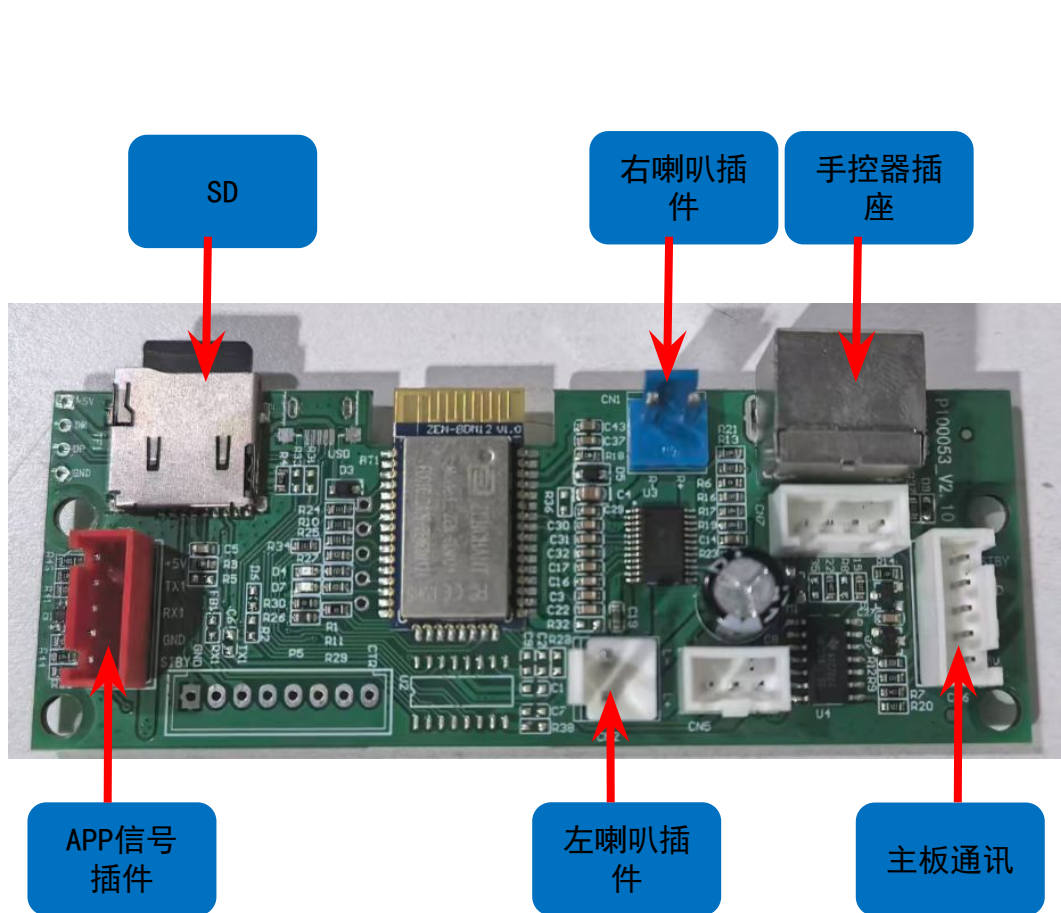

## 2.12 扶手信号转接板，心电检测板示意图

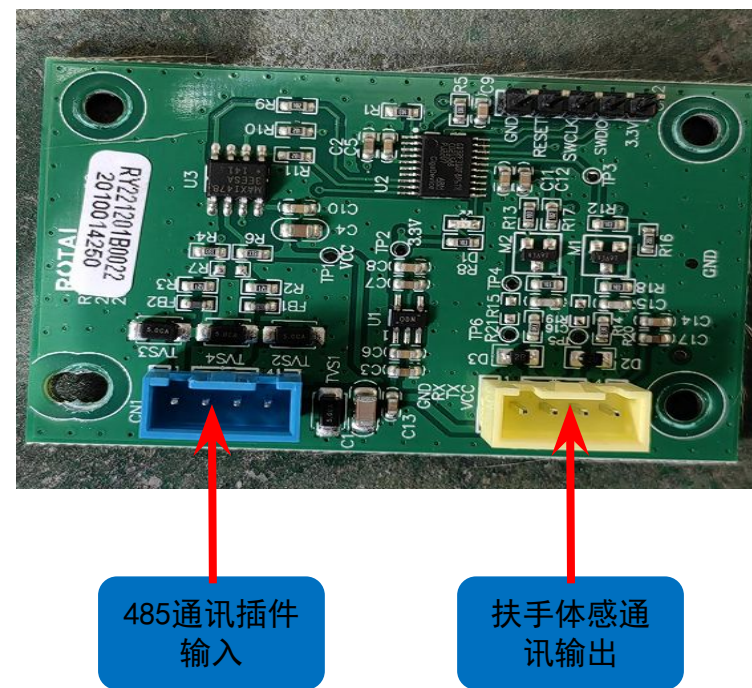
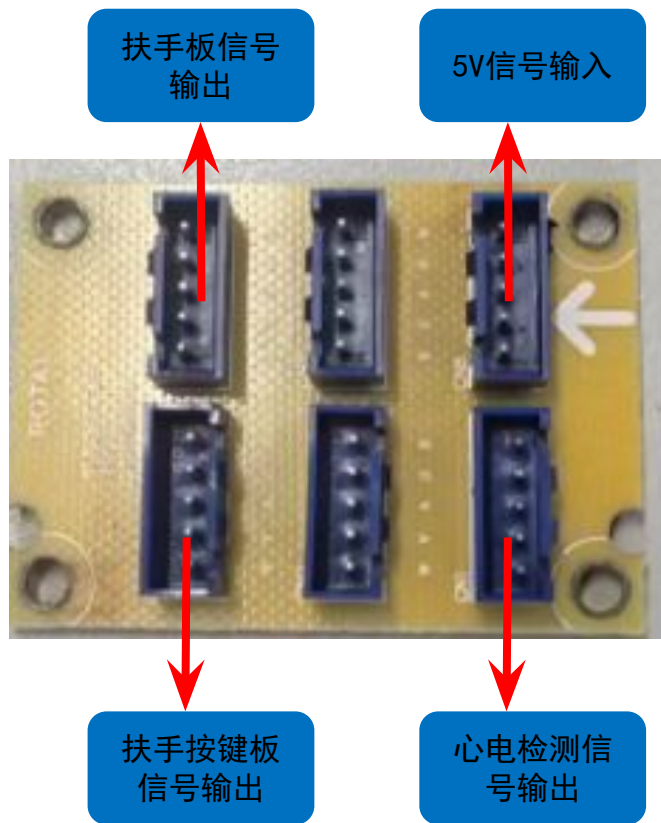

## 2.13 上机芯示意图

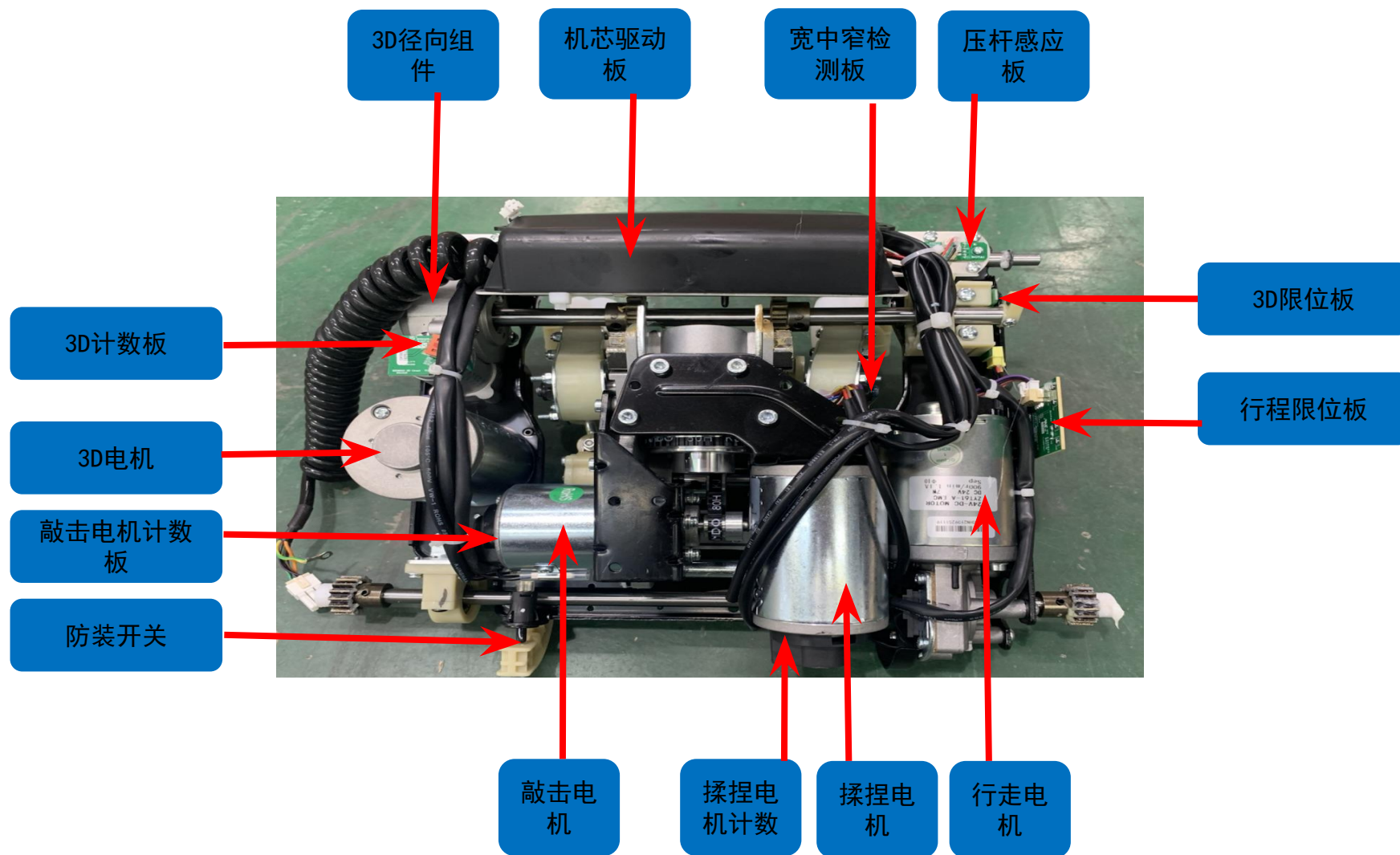

## 2.14 下机芯示意图

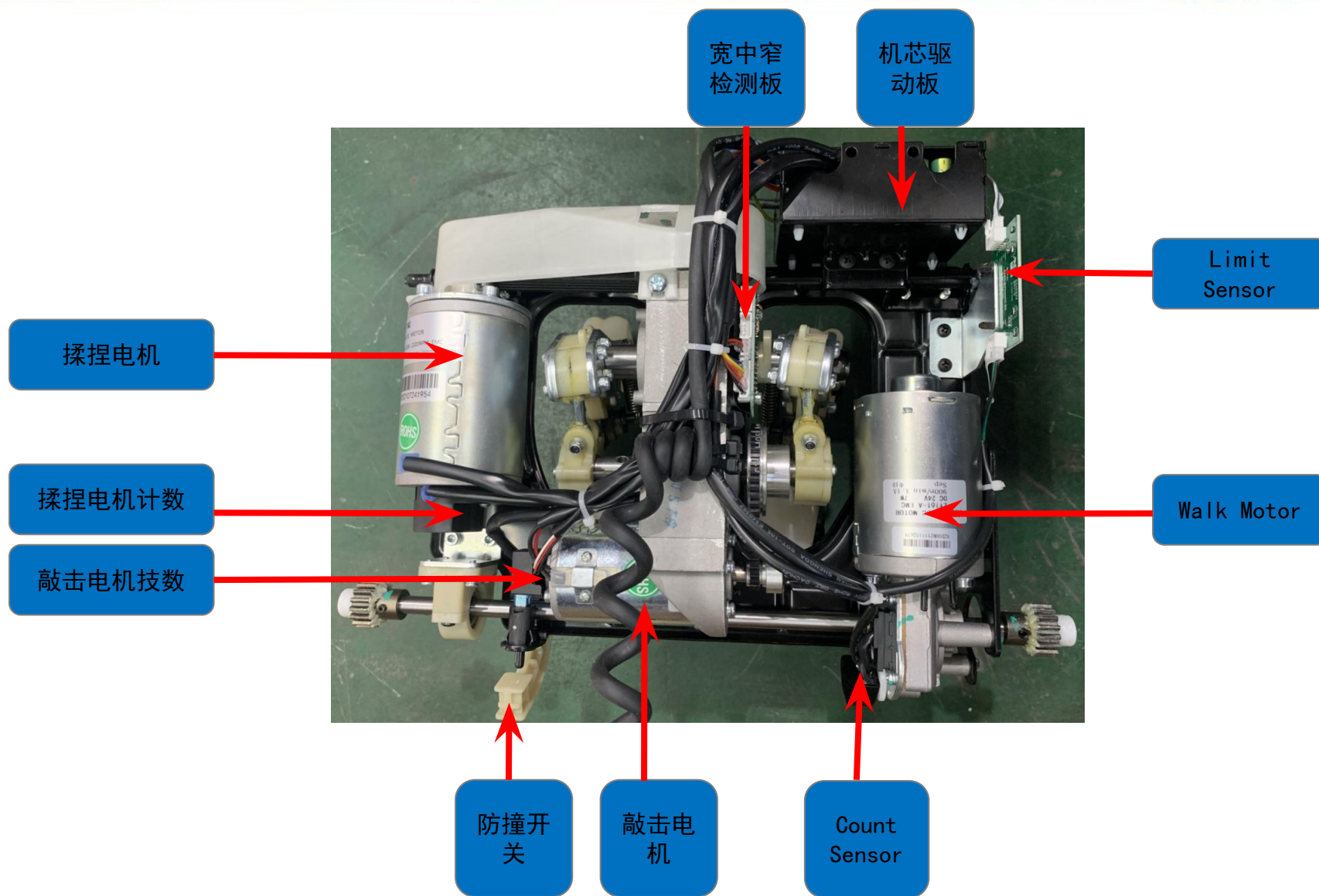

- ①. 维修工具介绍
- ②. 万用表介绍
- ③. 万用表各功能介绍
- ④. 测量线路导通的方法
- ⑤. 测量电机的方法
- ⑥. 测量交流电压的方法

## 3.1 维修工具介绍

### 配件 ACCESSORIES

1-焊锡丝

8-内六角套装 1.5 /2.0 /2.5 / 3.0 /3.5 /4.5/ 5.0/ 6.0MM

1-七合一剥线钳 7"/175MM

1-镍铁合金钢丝钳 6" /150MM

1-镍铁合金尖嘴钳 6"/150MM

1-镍铁合金活络扳手（双色柄） 8"/200MM

1-镜面抛光羊角锤（钢管柄） 0.25KG

1-钢卷尺（公制） 3m\*16mm

4-双色柄螺丝批 3\*75 - / 3\*75 + /6\*100 - / 6\*100 +

1-双色柄磁性套筒接杆

10-旋具批头 5-/6-/PH1/PH2/PH3/PZ1/PZ2/H4/H5/H6

6-精密钟表螺丝批 十字：#0/#1. 一字：1.4/2.0/2.4/3MM

1-精品外热式长寿命电烙铁 30W

1-吸锡器

1-万用表 830B



## 3.2 万用表介绍

介绍



### 测试档位的功能及作用

**电源开关:** 数字万用表电源的通断。

**数据保持开关:** 对测量数据进行记忆, 便于对测试数据进行对比。

**峰鸣档:** 测量二极管好坏、线路的通断、报警作用。

**电阻档:** 测量电阻的好坏及阻值。

**直流电压档:** 测量直流电压。

**交流电压档:** 测量交流电压。

**V $\Omega$  / COM:** V $\Omega$ 测试时红表笔端口(+极), COM测试时黑表笔端口(-极)

**注:** 在进行电阻或电压测试时要选择合适的量程, 量程过小测不出, 量程过大测试误差范围大; 测量电压不知道电压大小时, 选择较大的量程测量。

## 3.4 测量线路导通的方

开路

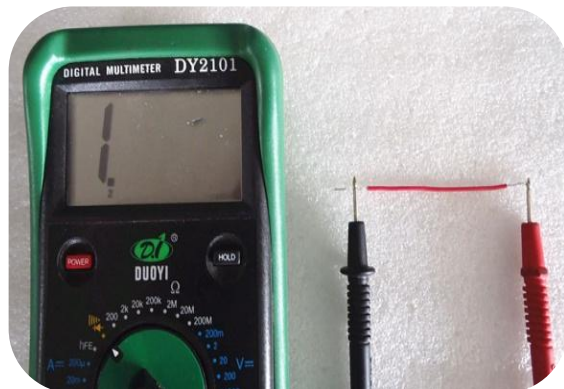

如左图所示，先将万用表打至蜂鸣档并将其电源开关打开，此时万用表显示“1.”；然后将两支表笔分布接触到图中红色电线的两端金属线头，此时万用表还是显示“1.”没有变化，则说明此电线中间有开路，即线路不通。

导通



如左图所示，跟上述一样方法测试，如万用表显示“.003”或是说“.00N”的数字并发出警报声，则说明此导线是导通的。

## 3.5 测量电机的方法

测量电机



万用表显示



判断结果

如左图所示显示为“1”，说明电机内部线圈已经开路不良。

如左图所示显示结果为“3-42.5”Ω，在正常阻值范围内，说明此电机是好的。

### 3.6 测量交流电压的方

测量家用插板电源  
(220V)



万用表  
量程选660



万用表显示



判断结果

如左图所示显示为“225”，说明此刻此组插座实际电压为225V。

如左图所示显示结果为“000”，说明此刻此组插座实际电压为0V。

## Chapter 4: Troubleshooting & Repair

- ①. 按摩椅无法开机
- ②. 机芯体形检测不过大纲
- ③. 行走电机不工作
- ④. 揉捏电机不工作
- ⑤. 敲击电机不工作
- ⑥. 3D不工作
- ⑦. 检测不到宽中窄
- ⑧. 靠背电动缸不工作
- ⑨. 小腿电动缸不工作
- ⑩. 前滑电动缸不工作
- ⑪. 零重力电动缸不工作
- ⑫. 小腿滚轮电机不工作
- ⑬. 小腿伸缩电机不工作
- ⑭. 气囊局部/某个部位不充气
- ⑮. 语音、音乐不工作
- ⑯. 无线不充电
- ⑰. 扶手按键不工作
- ⑱. 氛围灯不工作

# 4.1 按摩椅无法开机

按摩椅无法开机

查看主板灯是否亮起

主板灯亮

主板灯不亮

测量主板上蓝牙板插件上  
有无DC5V输出

测量主板电源插件有  
无DC5V输入

有输出

无输出

有输入

无输入

用万用表测量蓝牙板  
手控器插上有无DC5V  
输出

主板版

主板故障

用万用表测量电源板  
有无AC220V输入

有输出

无输出

有输入

无输入

测量蓝牙板控制器插件到平  
板连接线速是否通断

蓝牙板故障

电源板不良

保险丝不良

正常

不正常

平板故障

线束故障

5V输出插  
件



220V输入  
插件

主板灯  
蓝牙板  
插件

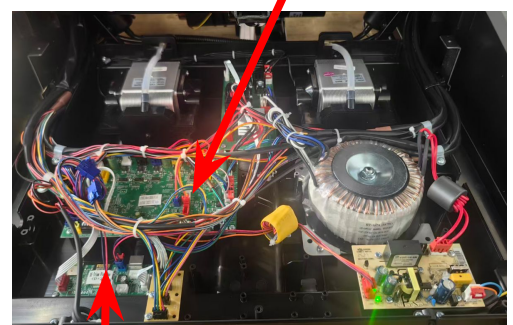
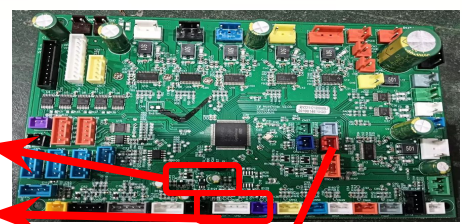

主板通  
讯插件

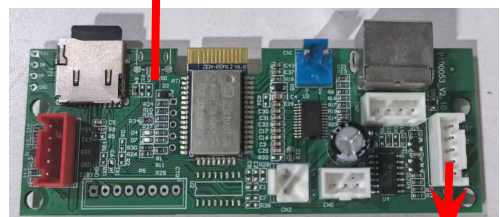

## 4.2 Body/Shape Detection Failure

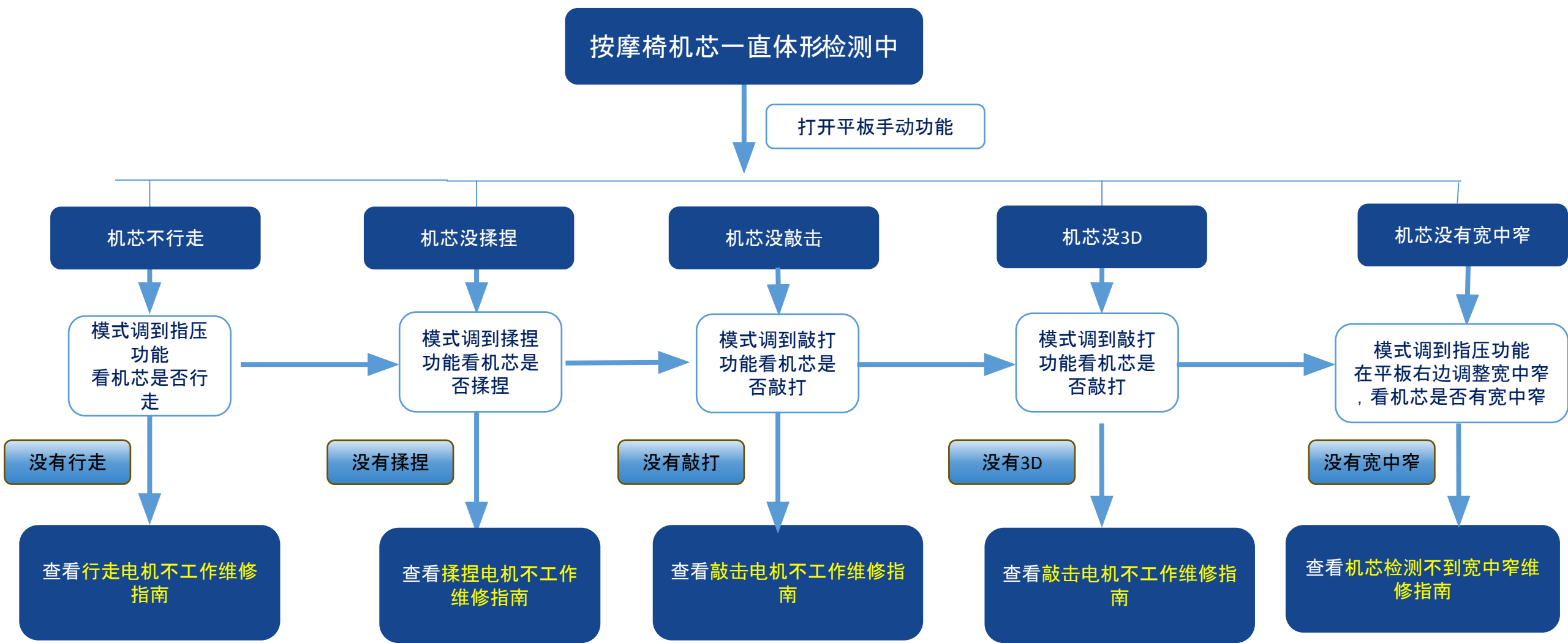

# 4.3 Walking (Up/Down) Motor Not Working

按摩椅行走电机不工作

打开平板手动指压功能, 选择定点模式, 按机芯上下键, 查看手控器声音

滴滴滴(连续快声)

滴、滴、滴(慢声)

万用表测量机芯板行程检测插件到行程检测板线束是否通断

机芯板行走电机插件与敲击电机插件对换

正常

不正常

行走

不行走

行程检测板故障

连接线故障

机芯板故障

行走电机故障

行走电机插件

敲击电机插件

敲击电机插件

行走电机插件

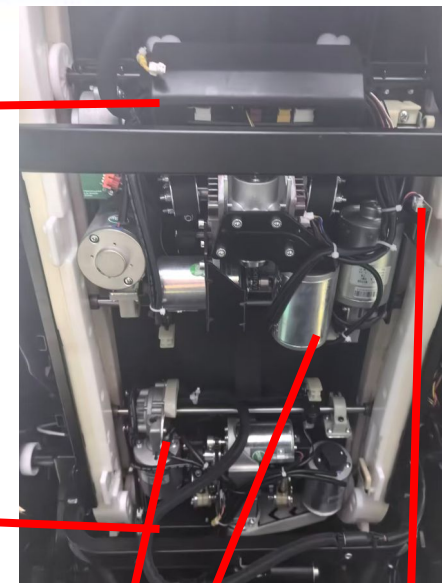
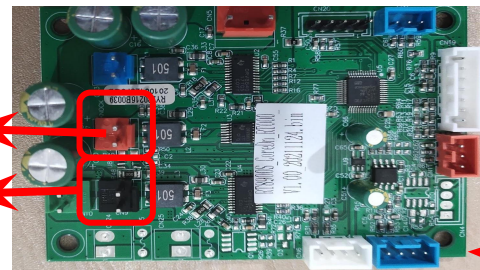
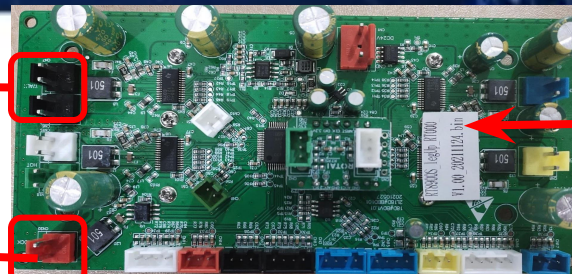

# 4.4 Kneading Motor Not Working

按摩椅揉捏电机不工作

打开平板手动功能, 选择揉敲手法, 把机芯主板上的揉捏电机插件插到3D电机插件, 调节3D功能看是否有揉捏

有揉捏

没有揉捏

机芯板故障

揉捏电机故障

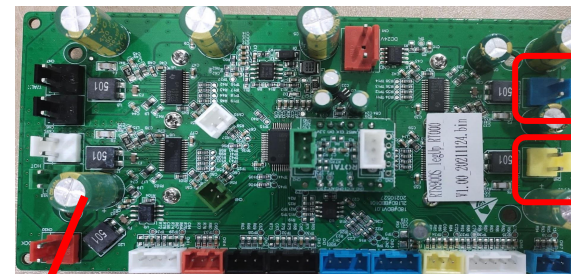

揉捏电机插件

3D电机插件

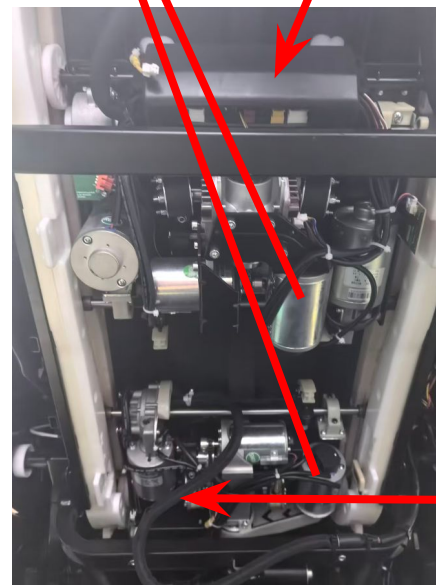

揉捏电机插件

敲击电机插件

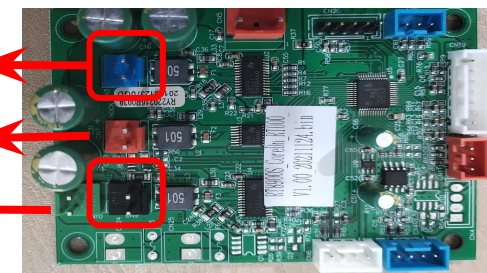

# 4.5 Tapping Motor Not Working

按摩椅敲击电机不工作

打开平板手动功能, 选择定点指压手法, 把机芯主板上的敲击电机插件插到行走电机插件, 看是否有敲击

有敲击

没有敲击

机芯板故障

敲击电机故障

行走电机插件

敲击电机插件

敲击电机插件

行走电机插件

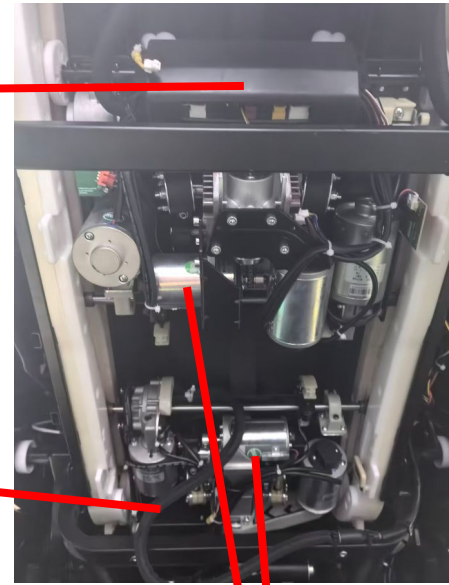

# 4.6 3D Motor Not Working

按摩椅敲击电机不工作

打开平板手动功能，选择揉敲手法，把机芯主板上的3D电机插件插到揉捏电机插件，选择3D功能，看是否有3D

有敲击

机芯板故障

没有敲击

敲击电机故障

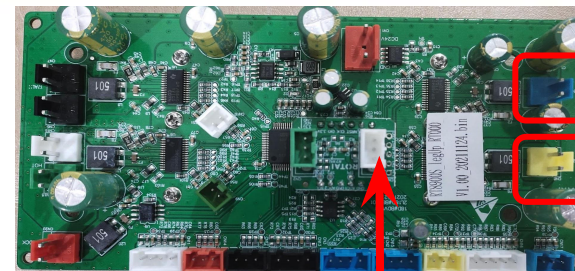

揉捏电机插件

3D电机插件

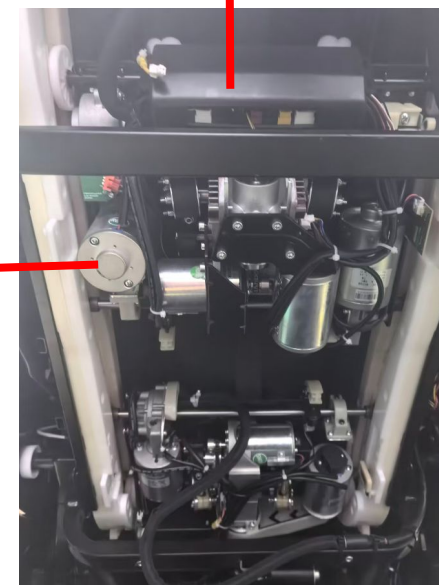

# 4.7 Width (Wide/Medium/Narrow) Detection Fail

按摩椅机芯检测不到宽中窄

按摩椅机芯检测不到宽中窄

万用表测量机芯板上揉捏计数插件上的VCC与GND有无3-5V输出

万用表测量机芯板上宽中窄检测插件上的VCC与GND有无3-5V输出

没有输出

有输出

没有输出

有输出

机芯板故障

揉捏计数故障

机芯板故障

宽中窄检测板故障

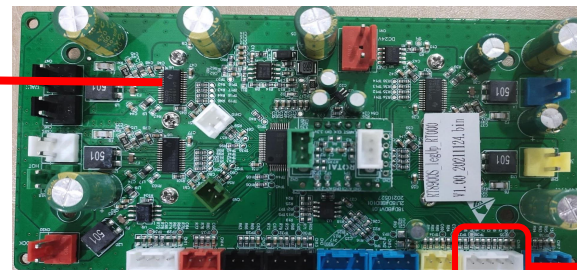
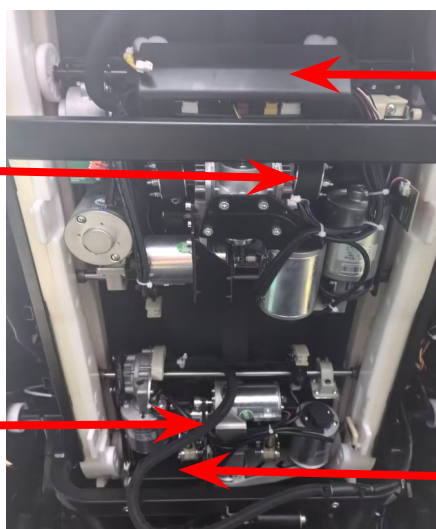
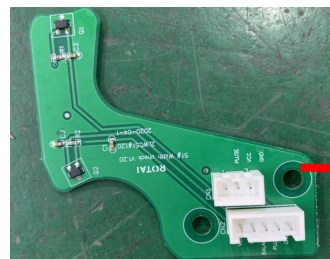

宽中窄信号

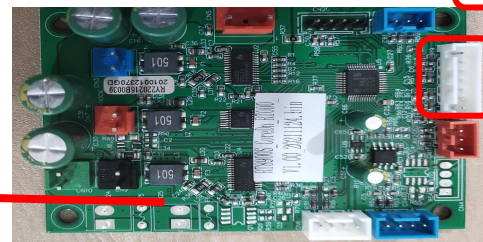

宽中窄信号

# 4.8 - 4.11 Actuators (Electric Cylinders) Not

按摩椅靠背电动缸不工作

打开平板, 开启零重力,  
万用表测量主板上电  
动缸插件有无DC24V输  
出

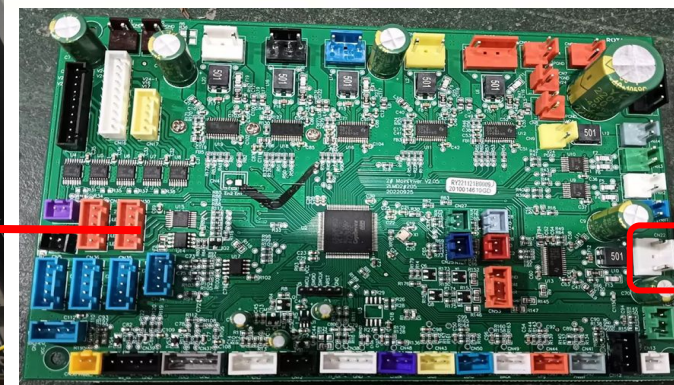
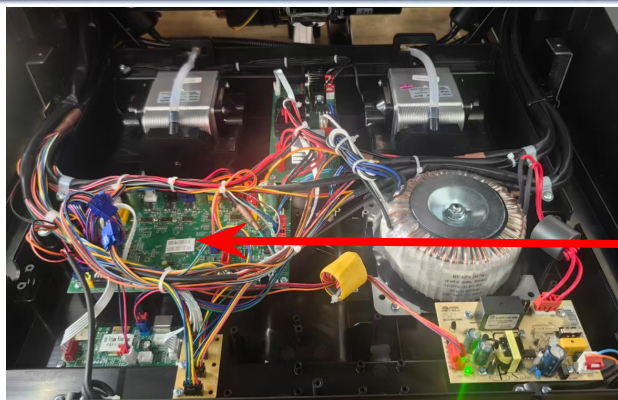

靠背电动缸

没有输出

有输出

主板故障

测量主板电动缸插件到  
电动缸连接线束是否通  
断

线束正常

线束不正常

电动缸故障

连接线故障

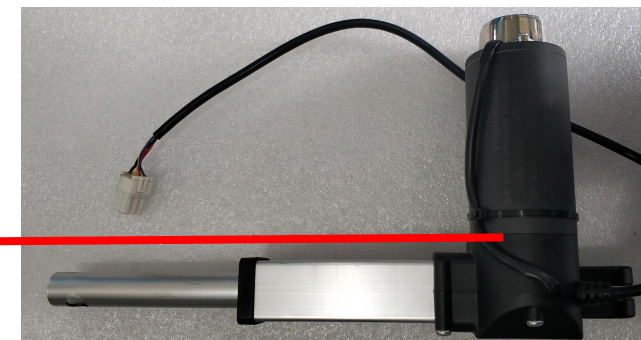
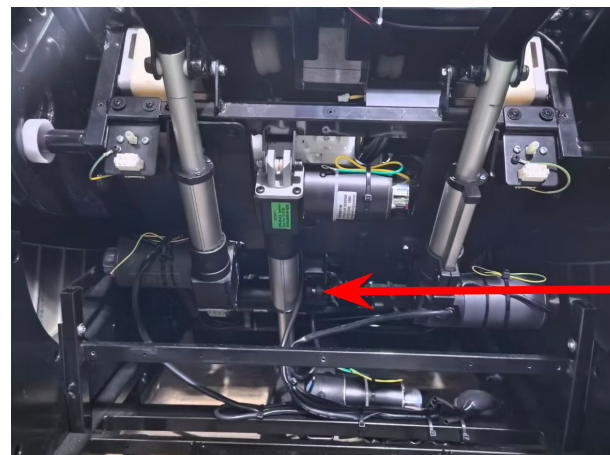

# 4.9 小腿电动缸不工作

右小腿电动缸

左小腿电动缸

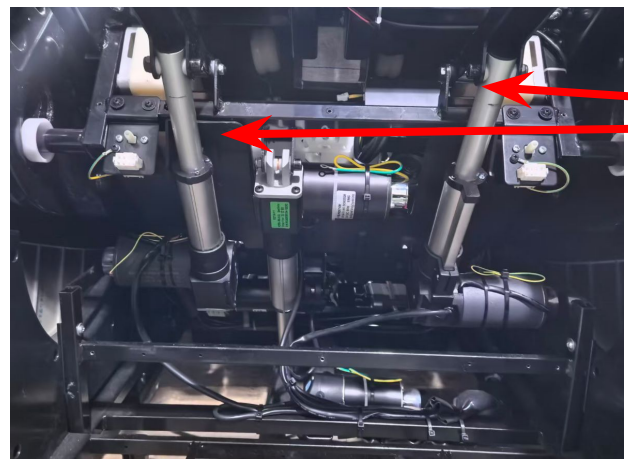
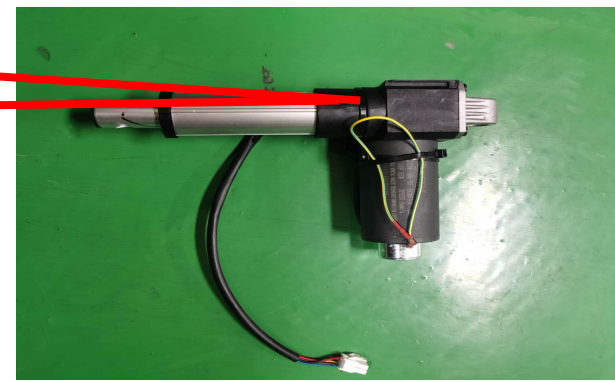
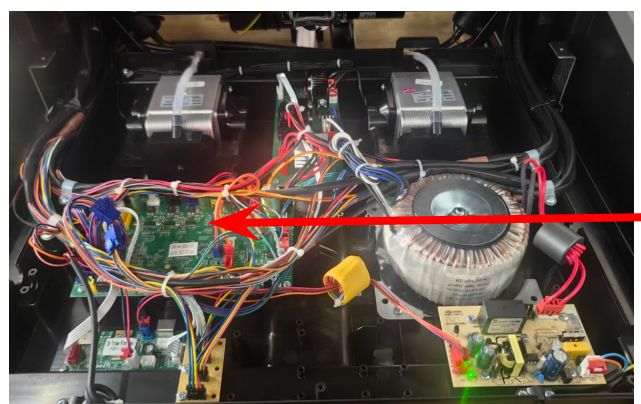
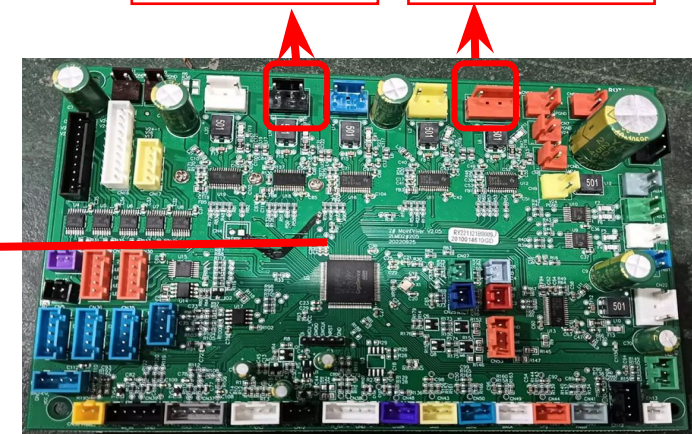

按摩椅靠背电动缸不工作

打开平板, 开启零重力, 万用表测量主板上电动缸插件有无DC24V输出

没有输出

有输出

主板故障

测量主板电动缸插件到电动缸连接线束是否通断

线束正常

线束不正常

电动缸故障

连接线故障

# 4.10 前滑电动缸不工作

按摩椅靠背电动缸不工作

打开平板, 开启零重力, 万用表测量主板上电动缸插件有无DC24V输出

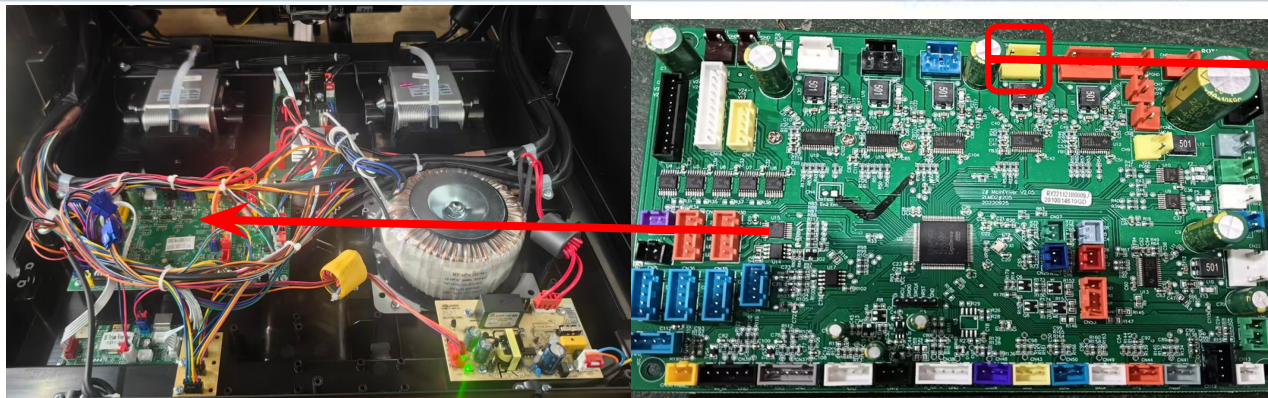

前滑电动缸

没有输出

有输出

主板故障

测量主板电动缸插件到电动缸连接线束是否通断

线束正常

线束不正常

电动缸故障

连接线故障

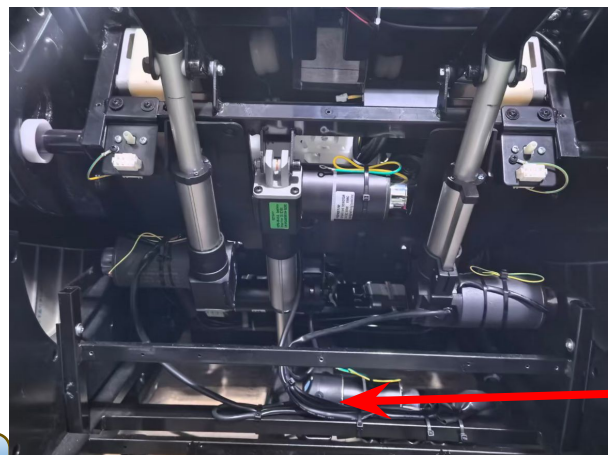

# 4.11 零重力电动缸不工作

按摩椅靠背电动缸不工作

打开平板, 开启零重力, 万用表测量主板上电动缸插件有无DC24V输出

没有输出

有输出

主板故障

测量主板电动缸插件到电动缸连接线束是否通断

线束正常

线束不正常

电动缸故障

连接线故障

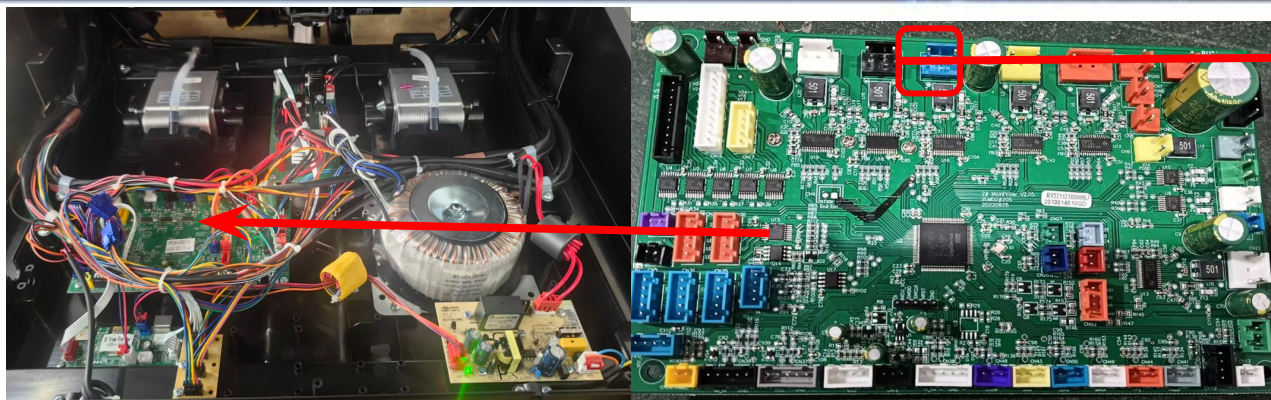

零重力电动缸

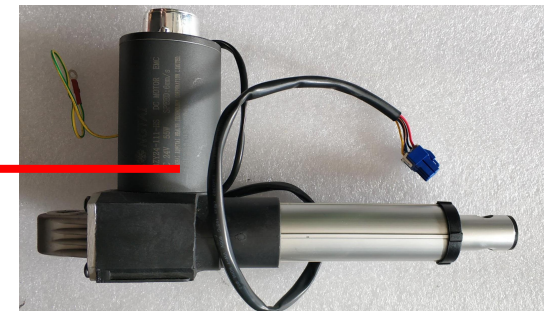
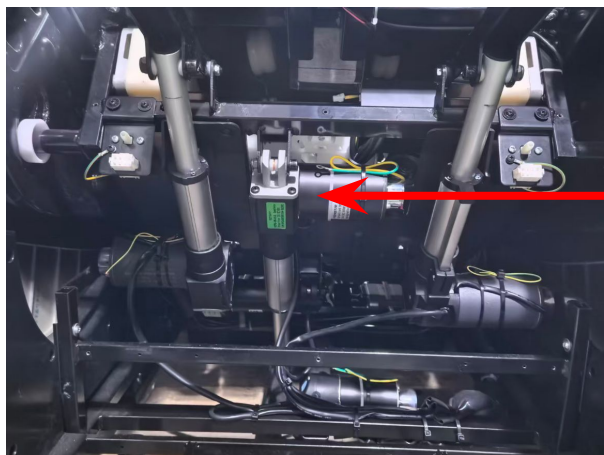

# 4.12 & 4.13 Calf Roller / Extension Motor Not

按摩椅小腿滚轮电机不工作

打开平板进入手动功能，打开小腿滚轮，用万用表测量小腿主板滚轮插件有无DC24V输出

没有输出

有输出

小腿板故障

检测小腿主板滚轮插件到滚轮电机线束及中间连接插件是否通断

线束正常

线束不正常

滚轮电机组件故障

线束故障



小腿滚轮

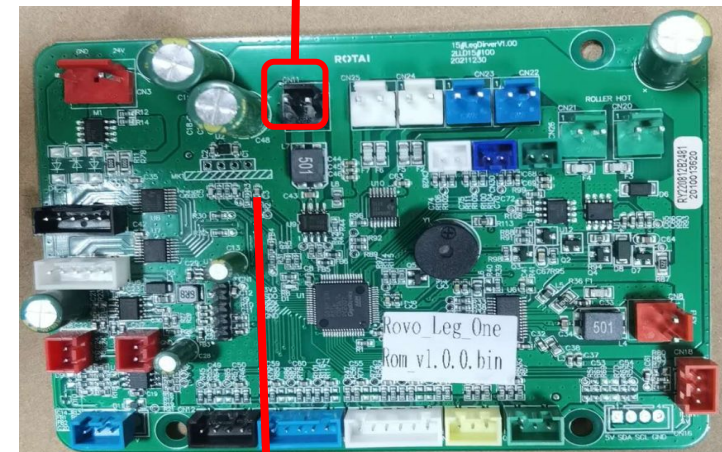

# 4.12 & 4.13 Calf Roller / Extension Motor Not

按摩椅小腿伸缩电机不工作

打开平板进入手动功能，打开小腿伸缩，用万用表测量小腿主板滚轮插件有无DC24V输出

没有输出

小腿板故障

有输出

检测小腿主板滚轮插件到滚轮电机线束及中间连接插件是否通断

线束正常

小腿伸缩电机故障

线束不正常

线束故障

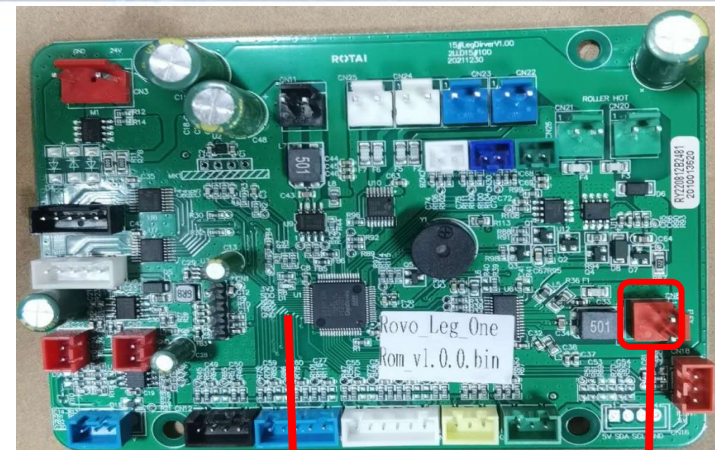

小腿伸缩



# 4.14 Airbags Not Inflating

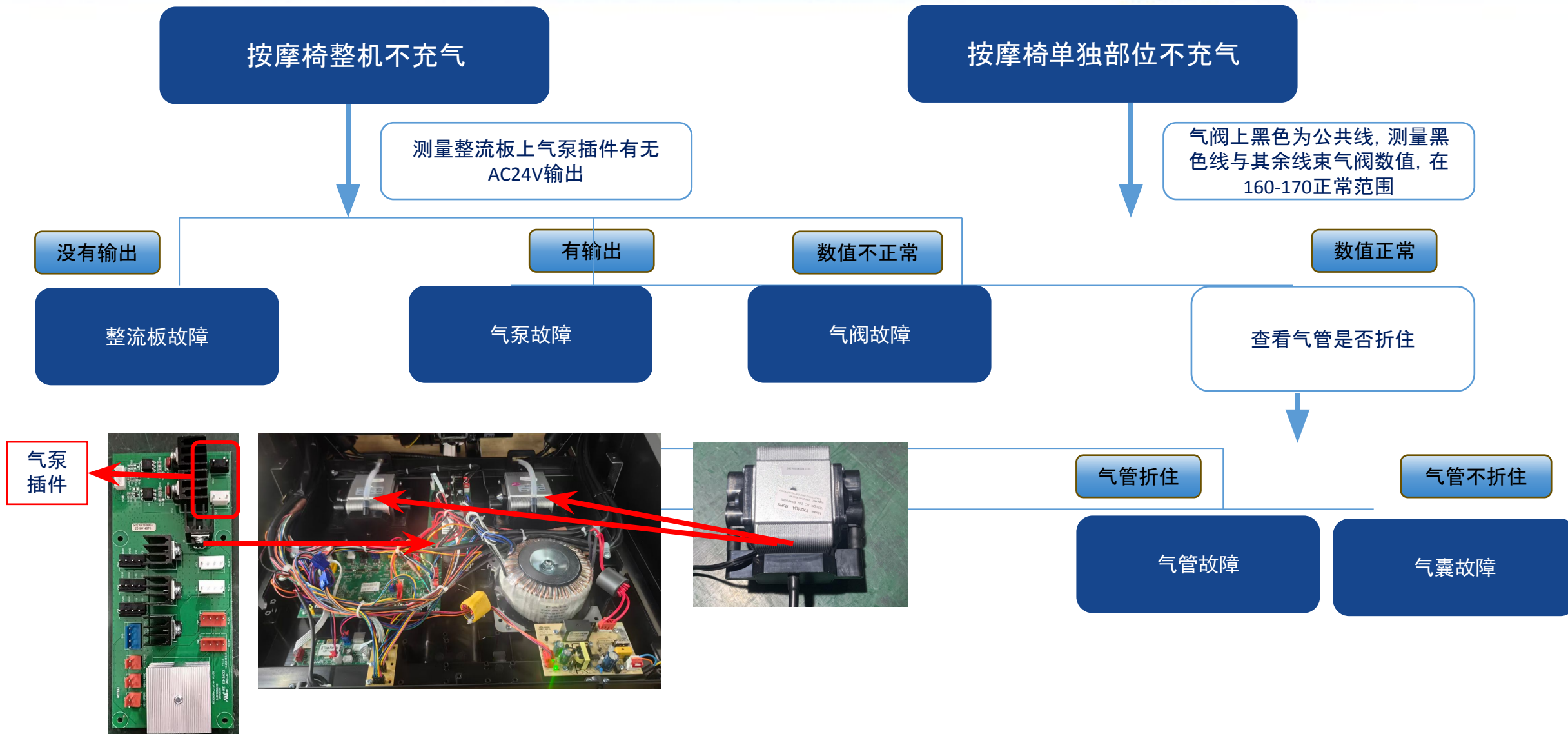

# 4.15 Sound/Music Issues

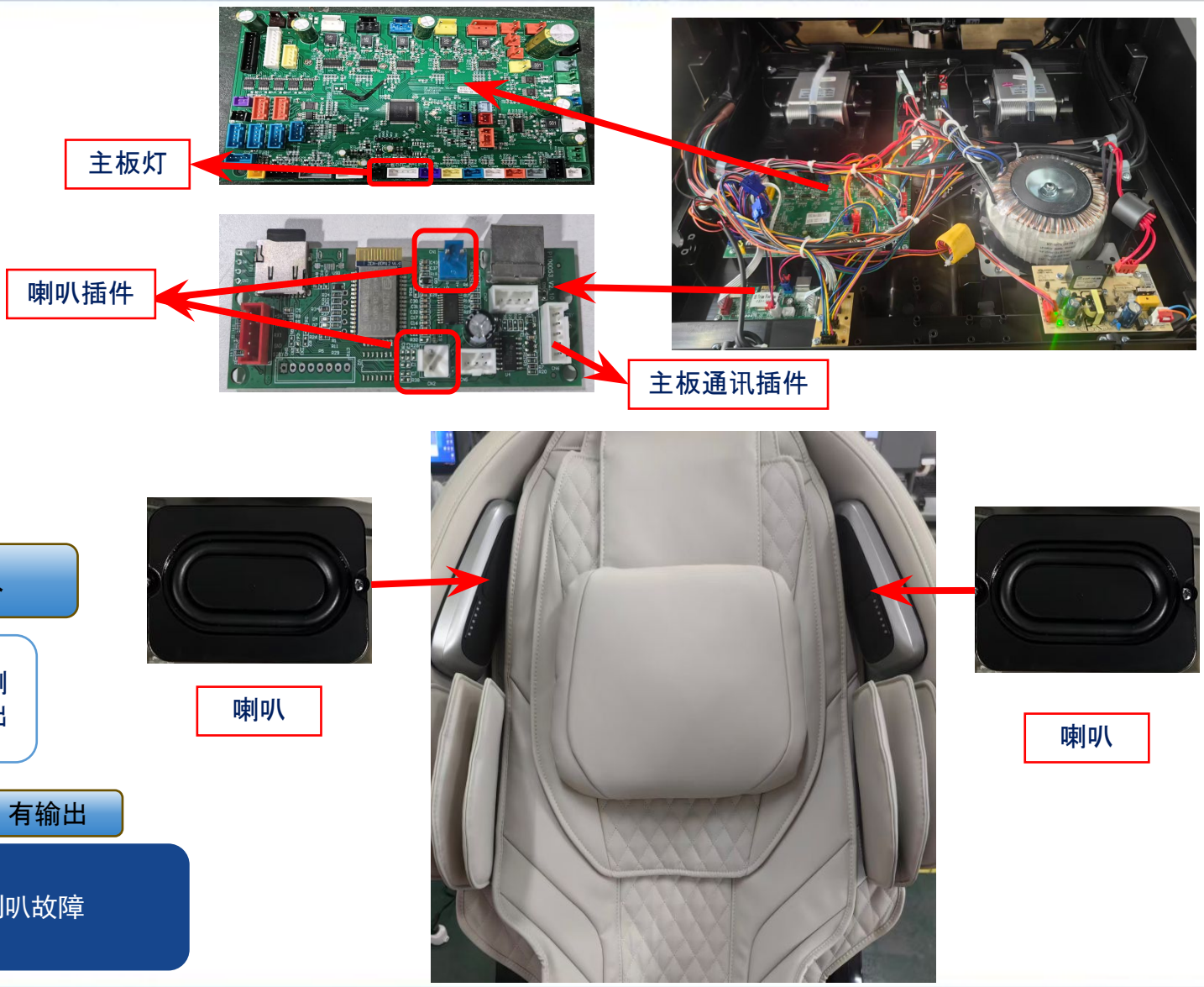
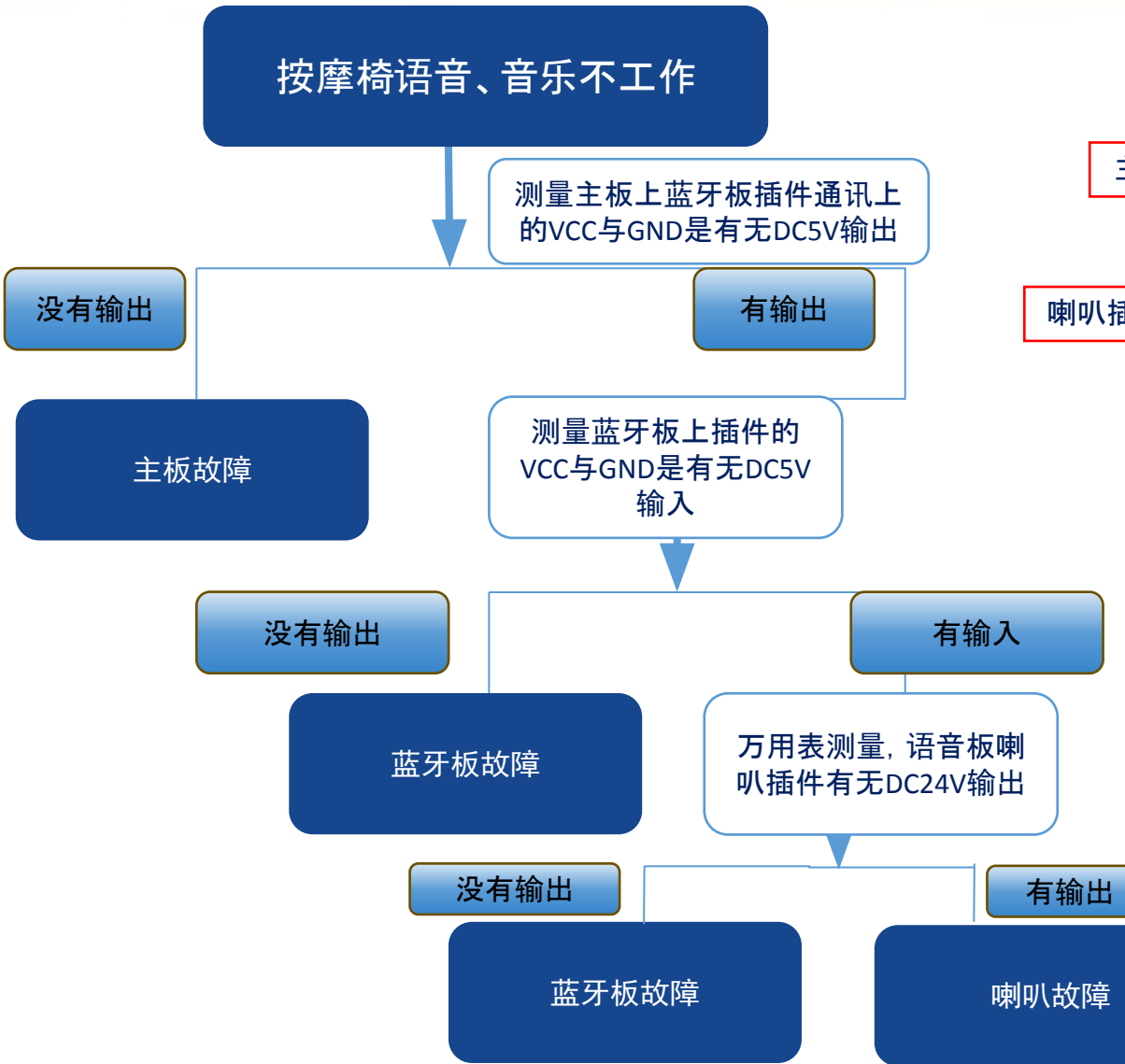

# 4.16 Wireless Charging Fail

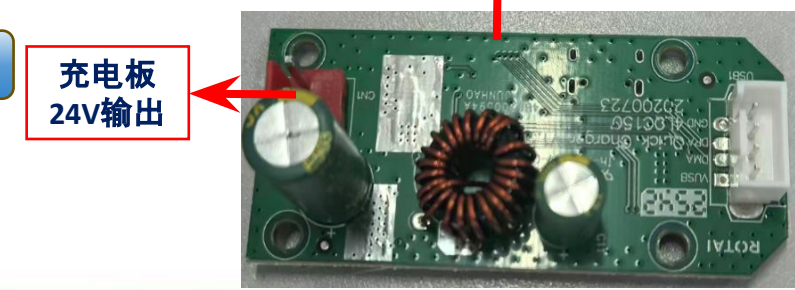
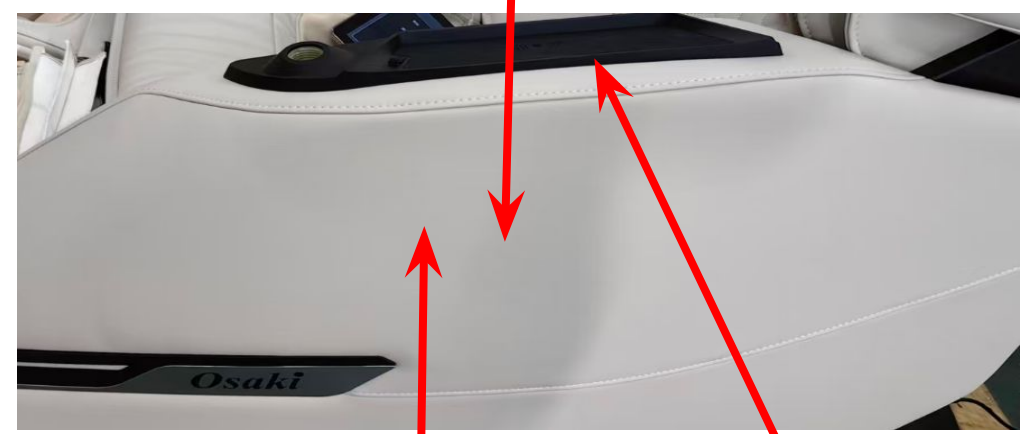
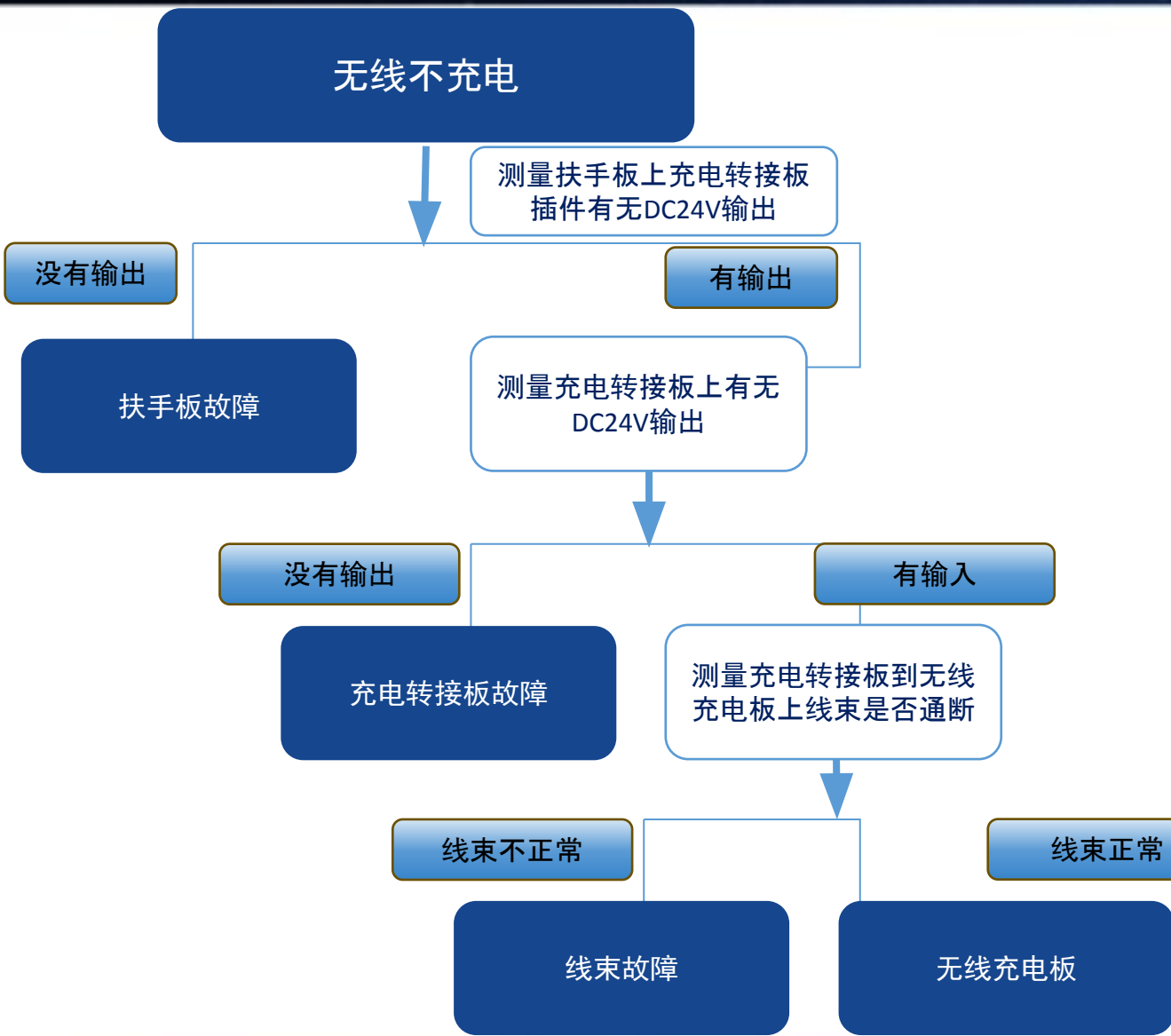

# 4.17 扶手按键不工

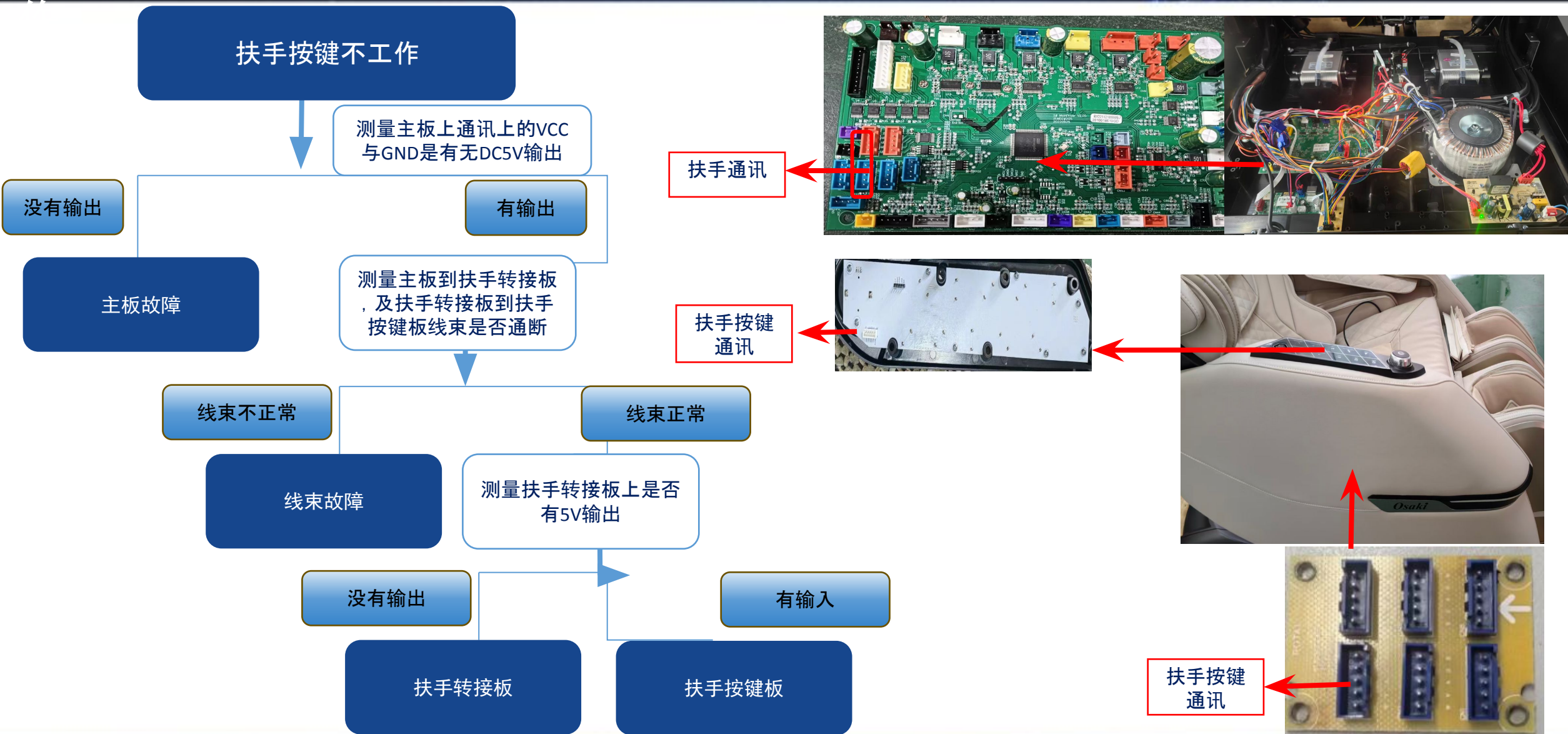

# 4.18 氛围灯不工

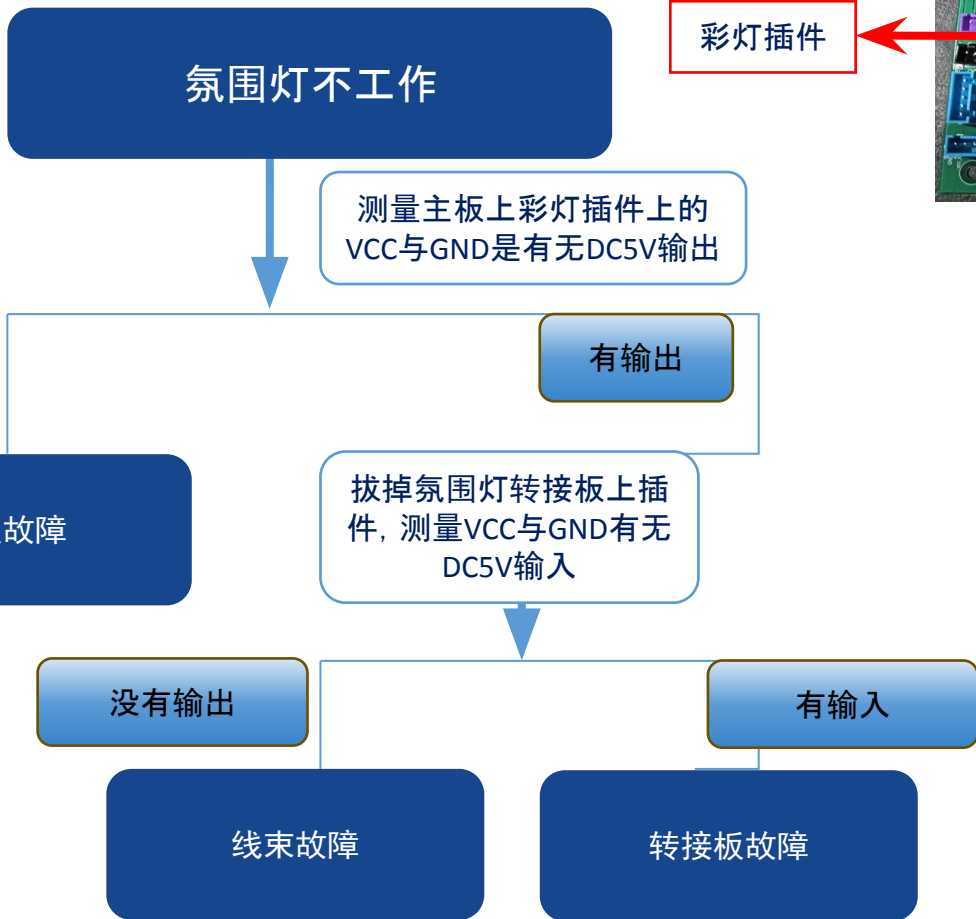

彩灯插件

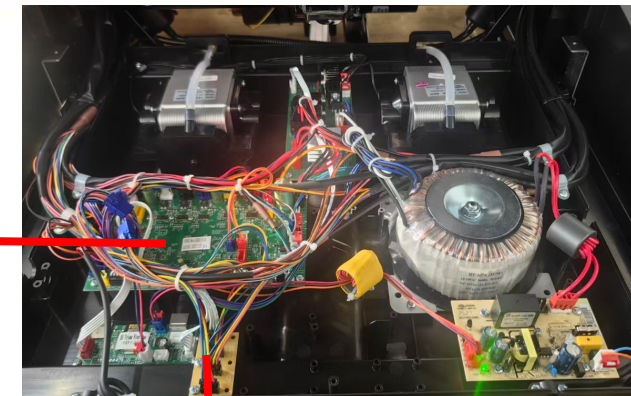
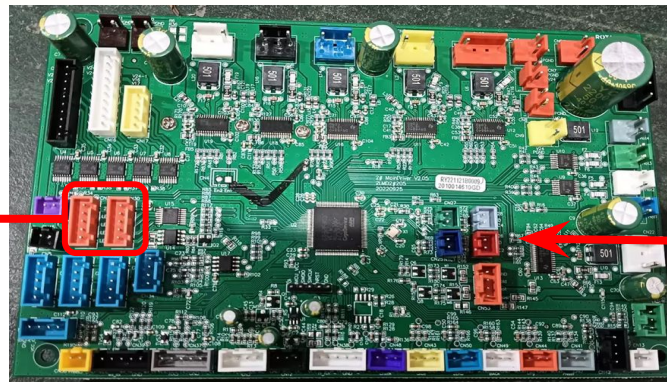

彩灯转接板



**ROTAI**  
荣泰



**荣泰 更专业的按摩椅**