

Service Manual



Model: 3D Vibe

Customer Service
Department

Ningbo Zhouqi Health and Technology Company

Contents

1

Product
Parameters
&
Functions

2

Chair
Structure

3

Decomposition
Diagram

4

Problem
&
Maintenance

5

Tool List



一、Product Parameters and Functions

- 1、Product Parameters
- 2、Fuctions
- 3、Remote Instruction
- 4、Product Size

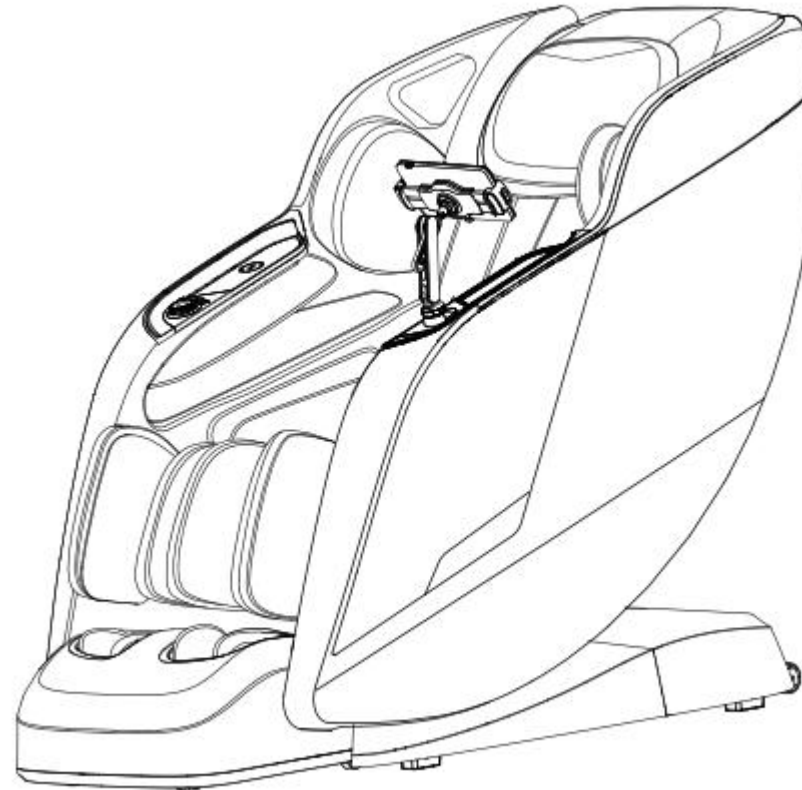

1.1.1·Product Parameters

项目名称	规格描述
Product name	Massage Chair
Model No	3D Vibe
Rated frequency	60HZ
Rated voltage	110V
Rated power	180W
Safety design	Class 1
Net weight	216.1lbs
Gross weight	260.1lbs
Product size	62.5" *29.7" *43.7

1.2.1·Function Introduction

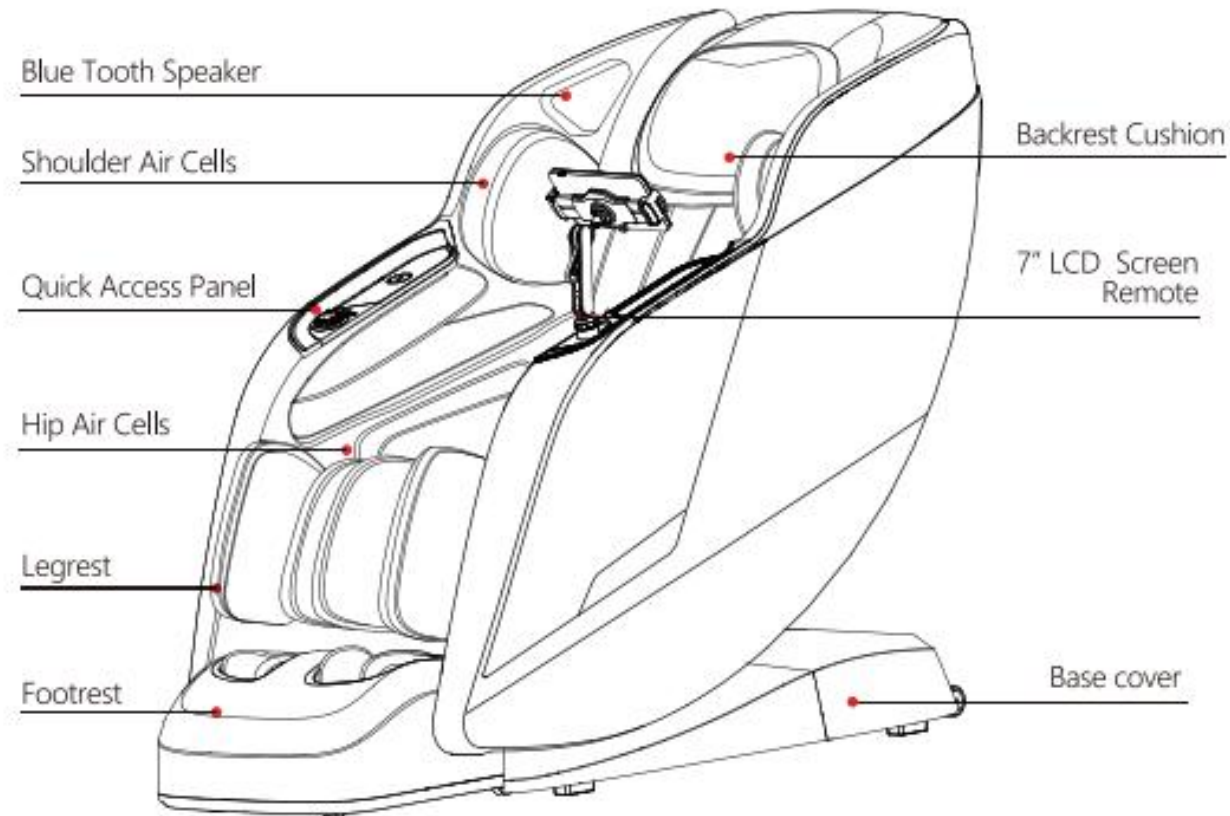

1.3.1·Remote Control



1.Turn on LCD SCREEN to start massaging.



2.There are six option on the home page:CLASSICAL,CUSTOMIZED,POSITION MANUAL,SETTING,FAVORITES.



3.After choose the CLASSIC mode,there are 8 programs
RENEW MODE,STRETCH
MODE,FATIGUE&RELIEF,HAWAIIAN
MODE,MORNING GLOW,NIGHT
MODE,POWER TOUCH,NAP MODE.

1.3.1·Remote Control



4.After choose the SPECIALTY mode,there are 8 programs :
ACUPOINT,RELAX,GENTLE,SHIATSU,DEEP TISSUE,ATHLETIC,CIRCULATION,RECHARGE.



5.After choose the ELITE TARGET mode,there are 8 programs :
REST,FENG CHI,BACK FOCUS,LUMBAR FOCUS,WAIST & HIP FOCUS,LEG & FEET FOCUS,UPPER BODY,LOWER BODY.



6.After selecting the automatic massage program, the chair will start to body test.For enjoying the most comfortable massage,please put your head on the head rest and try to sit in the deepest of the chair.

1.3.1·Remote Control



7.After the body test, the shoulder position test will be started, the massage hand will move from top to the shoulder position and start kneading to lock your shoulder position.



8.After choose the CUSTOM mode, it will enter the CUSTOM mode page: In this page, you can select the body parts of the air cells massage,such as the FOLL BODY,SHOULDER,HAND,WAIST-HIP,LEG-FOOT massage, or you can select the massage action: like KNEADING,PERCUSSION ,ACUPRESSURE,FLAP,SLAP, MIXTURE.



9.In MANUAL mode massage position page,you can control the massage hand position through FIXED POINT, FULL BODY, AREA,UP and DOWN.

In "full body" mode, "up" and "down" are invalid.

1.3.1·Remote Control



10. In MANUAL mode OPTIONS page, you can choose the other functions you may need, such as: HEATING, LEG KNEADING, FOOT ROLLING, RANGE, WIDE, MIDDLE and NARROW.



11. There are 4 functions: HEATING, ROLLING, AIR MASSAGE and ADD TO FAVORITES. You can add your favorite massage program into ADD TO FAVORITES.

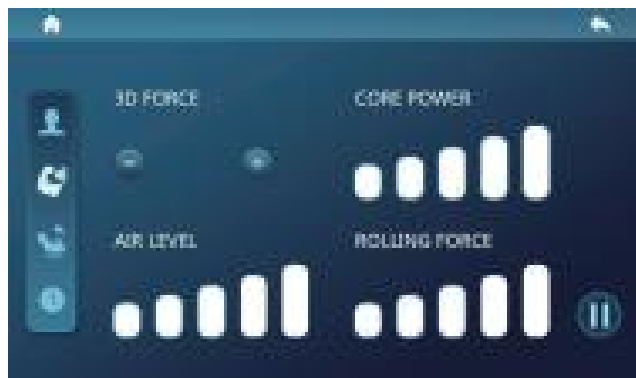

12. This button helps to control: 4D FORCE, CORE POWER, AIR LEVEL and ROLLING FORCE. Note: some actions are controlled by an automatic program, and manual adjustment is invalid at this time.

1.3.1·Remote Control

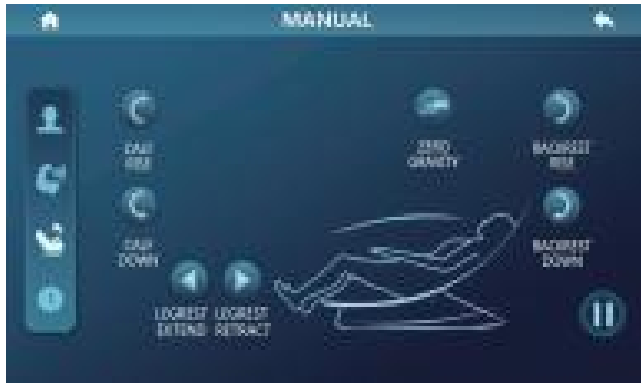

13.This button to help to control: calf rise,calf down, zero gravity, backrest rise,legrest extend, legrest retract, backrest down.

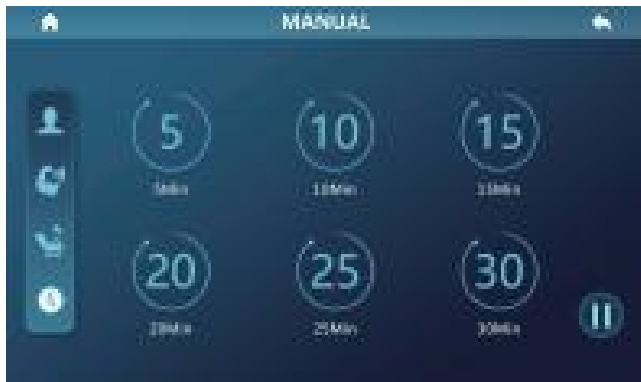

14.This button to change massage time:5Min,10Min,15Min,20Min,25Min,30Min.



15.Home page SETTING you can control The BLUETOOTH,LANGUAGE,VOICE,KEY TONE DORMANCY,BACKLIGHT.

1.3.1·Remote Control



16.FAVORITES:You can add the programs you like into it and when you feel uncomfortable you can delete it.

1.4.1·Product Size

Chair Size

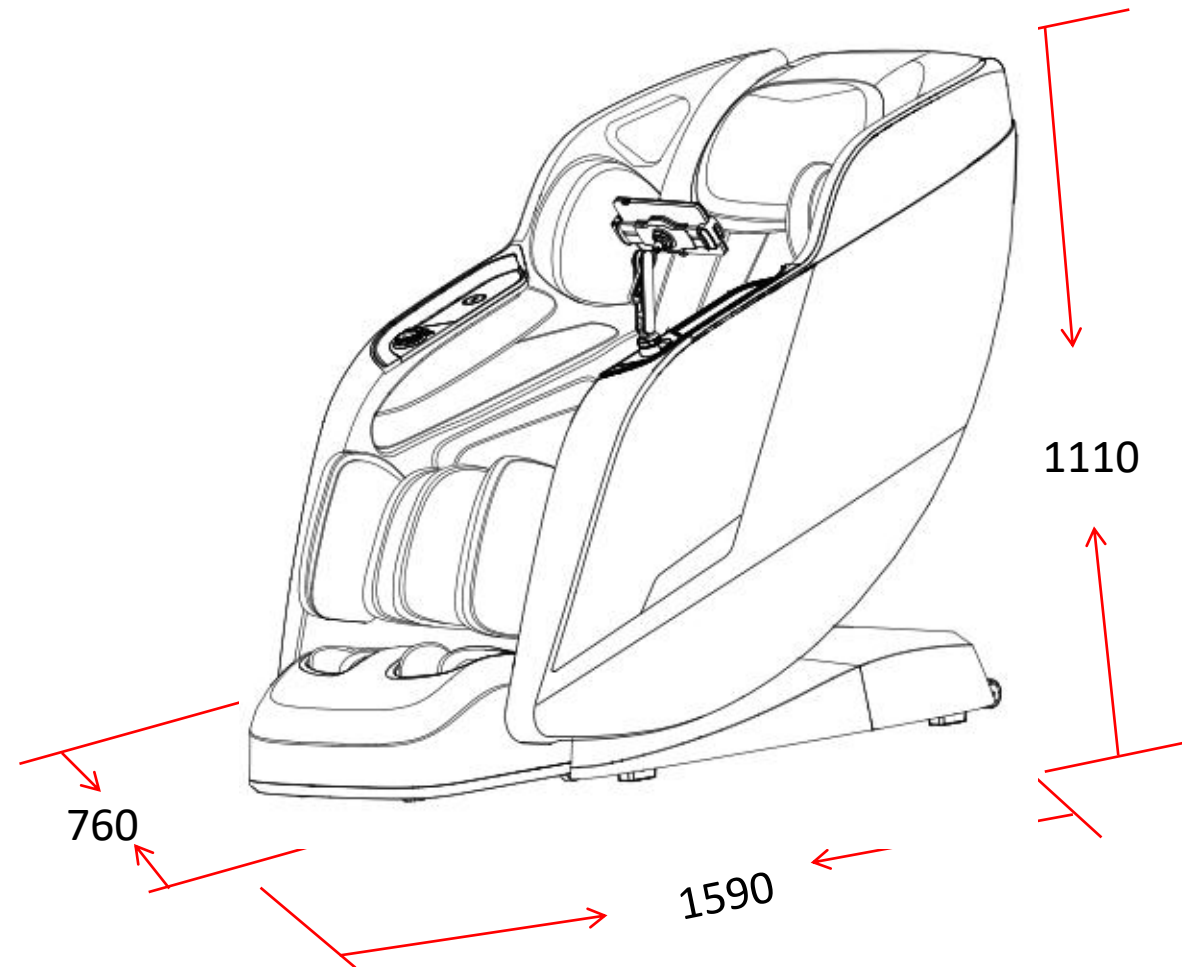

1.4.2·Product Size

Package Size

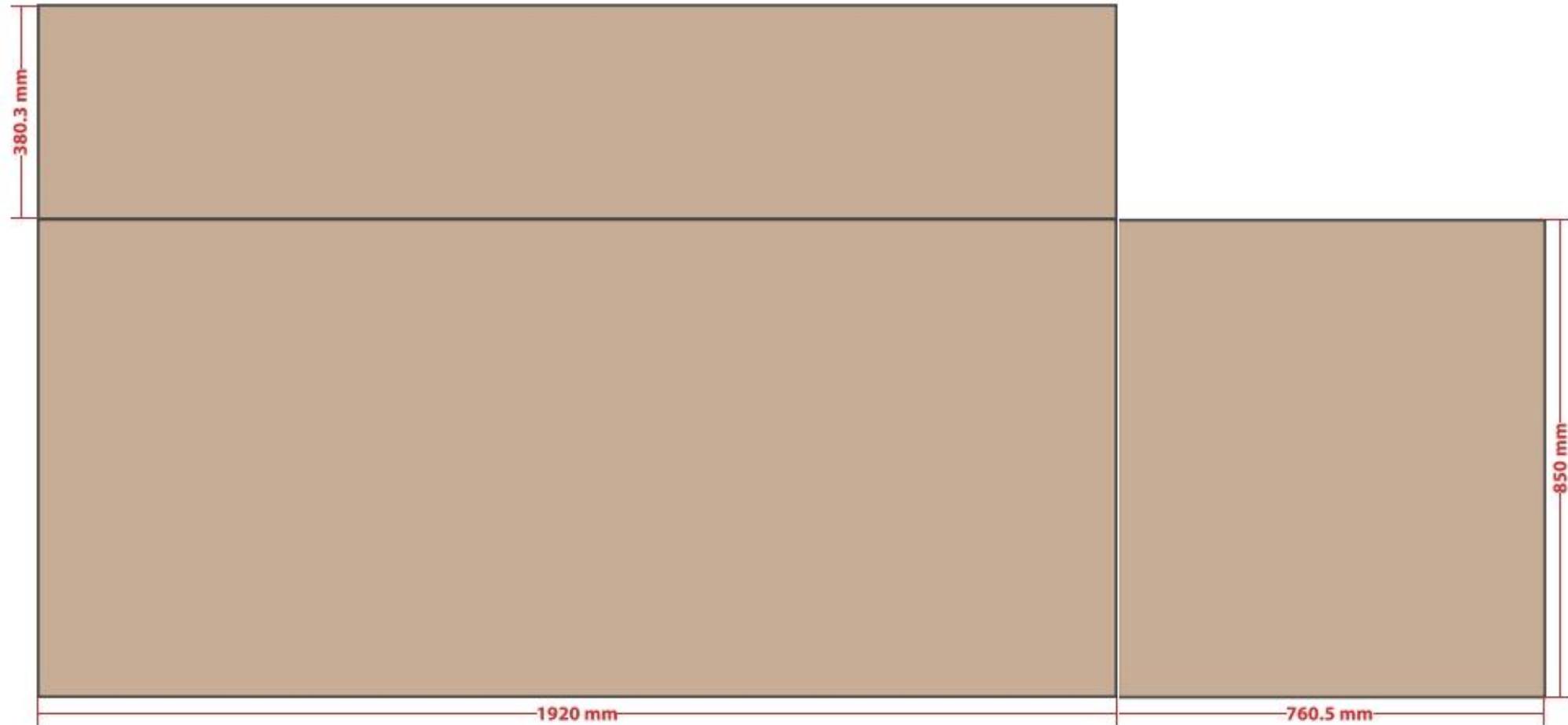

二、Chair Structure

- 1、Name of Parts
- 2、Internal parts diagram
- 3、Internal wiring of Electrical Control

Box

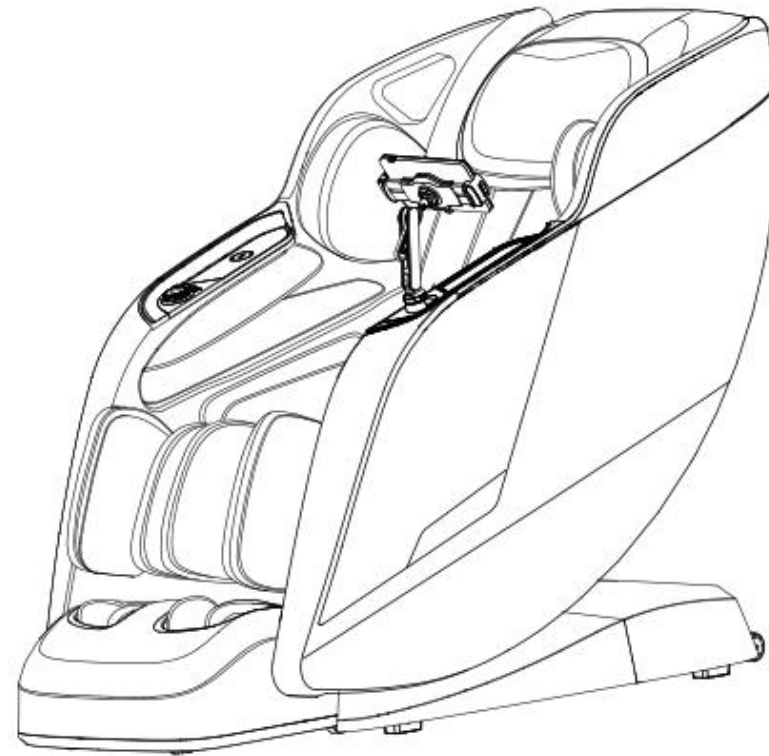

2.1.1、 Name of Parts

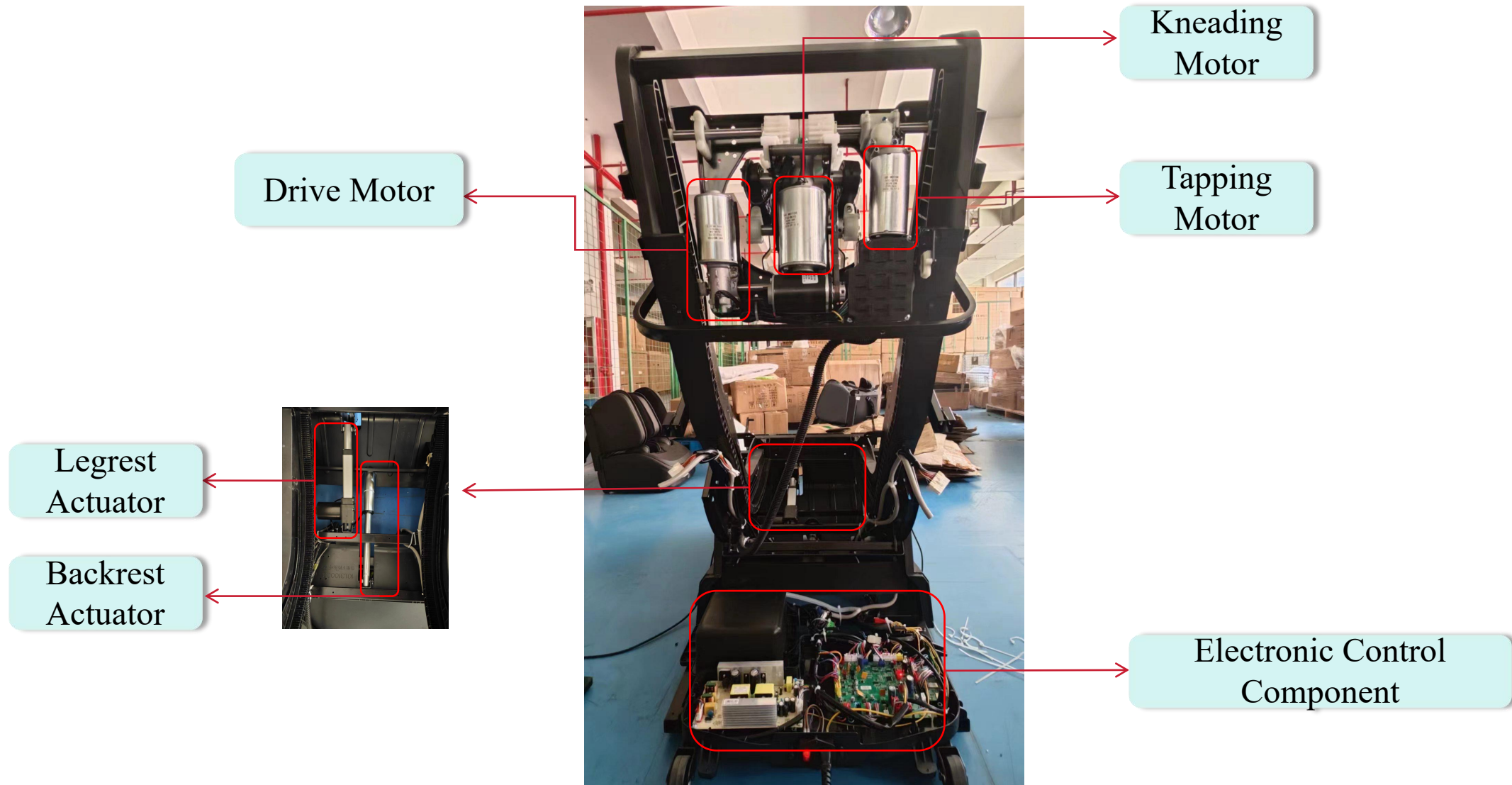

2.2.1、Internal Parts Diagram

PCB

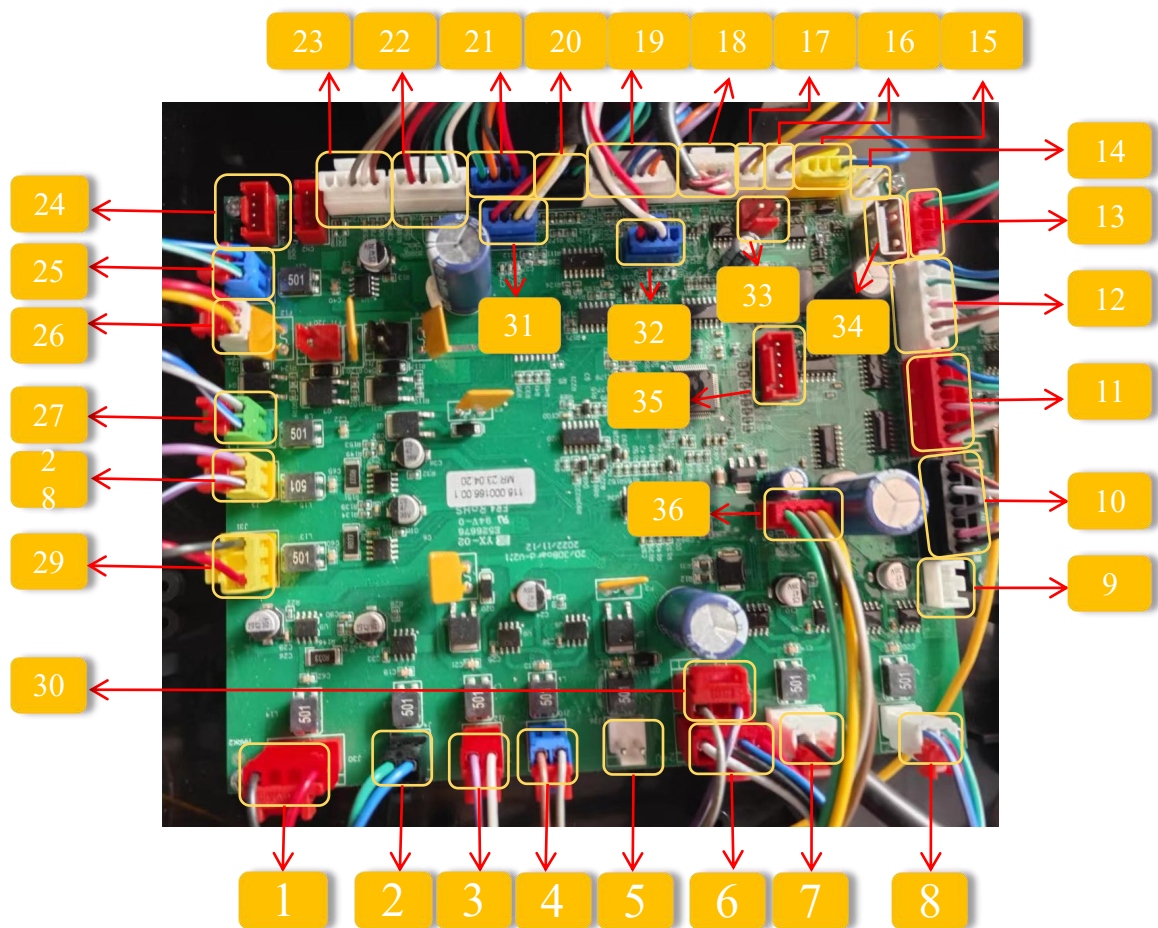

编号	端口作用	编号	端口作用	编号	端口作用
1	腿部推杆	13	手机充电	25	脚部升降电机
2	机芯行走电机	14	12V预留 (蓝牙不控制)	26	脚滚电机
3	机芯敲击电机	15	负离子风扇	27	腿滚电机
4	机芯揉捏电机	16	LED灯 12V	28	脚部升降电机
5	脚部震动电机	17	LED灯 12V	29	背部推杆
6	24V输入供电	18	手控制器	30	无线充电
7	24v气泵	19	机芯宽中窄肩位信号, 揉捏、行走计数	31	快捷键
8	3D机芯电机	20	上下限位	32	蓝牙
9	220V气泵控制	21	心率检测	33	12V输出
10	腿部电磁阀	22	脚部信号&防夹信号	34	USB供电
11	左扶手电磁阀	23	3D机芯信号	35	程序下载口
12	右扶手电磁阀	24	RGB彩灯控制	36	5V输入供电

2.2.2、 Internal Parts Diagram

Switch Power Bluetooth Board

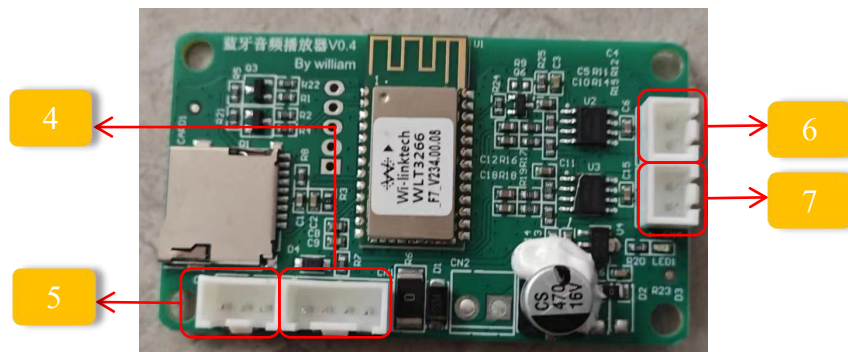
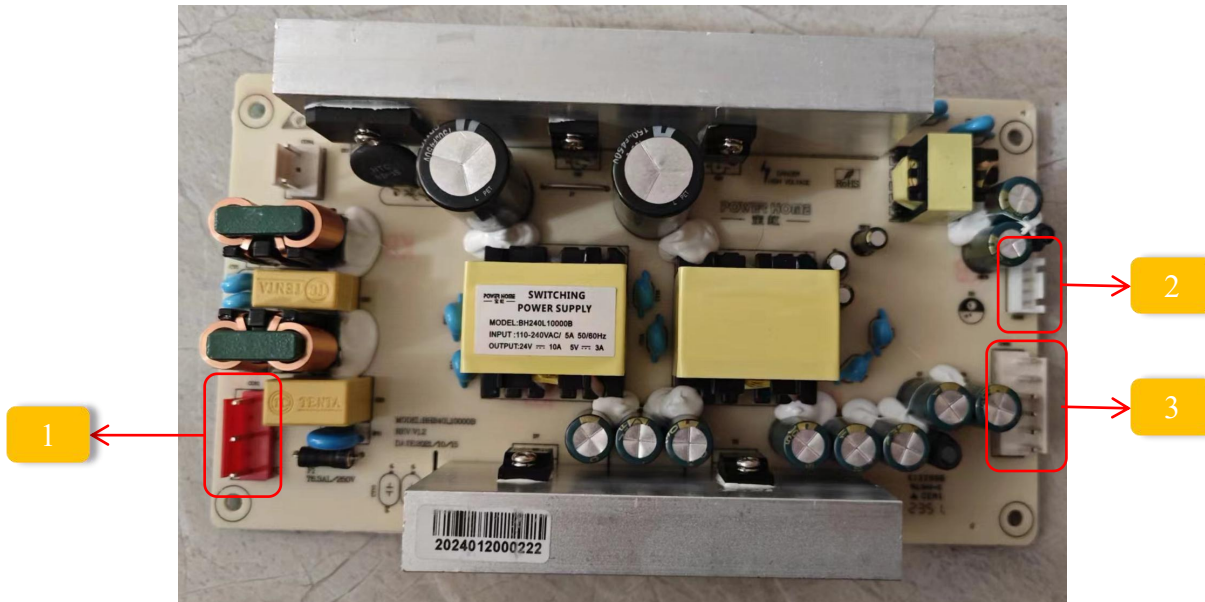

Number	Function
1	AC220V input
2	DC5V output
3	DC24 output
4	Amplifier Board Control Cable
5	Sleep Aid Music Line
6	Left audio signal output
7	Right audio signal output

2.3.1、 Internal wiring of Electrical Control Box

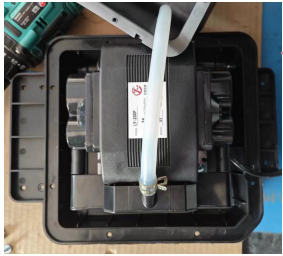

Air Pump

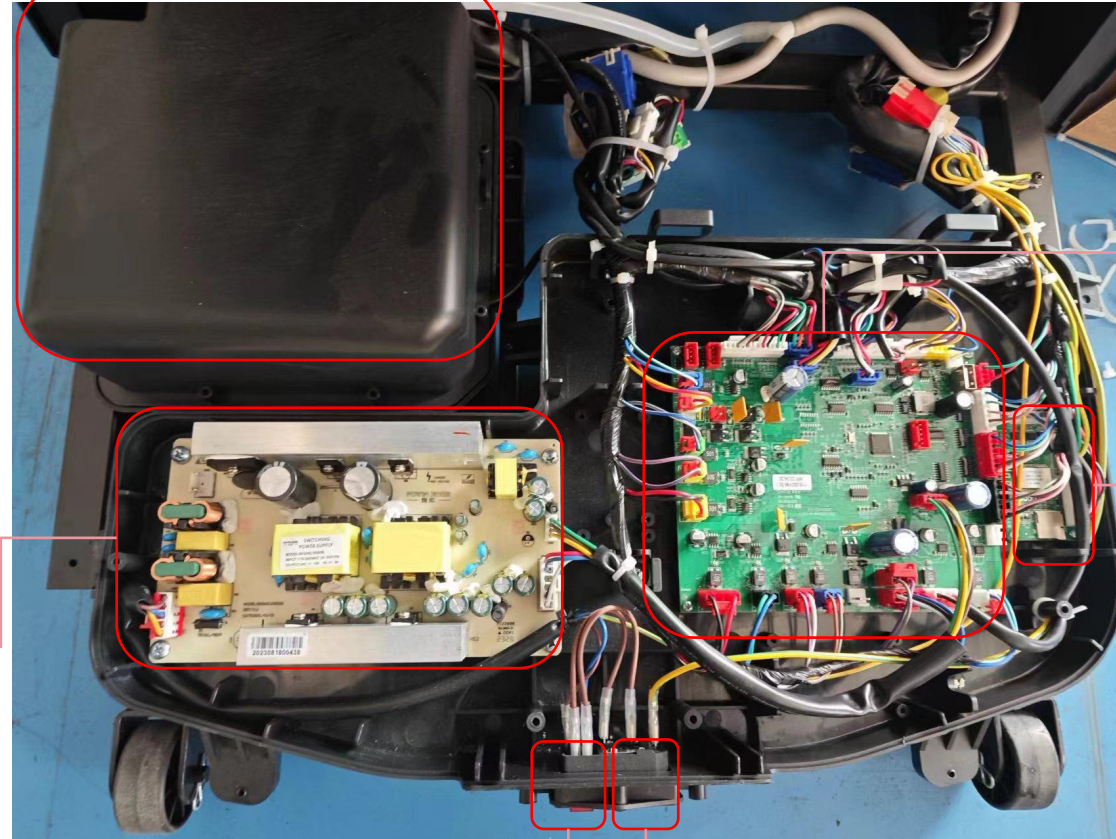

PCB

Bluetooth Board

Dual Output Switching Power

Switch

Power Socket

三、 Decomposition Diagram

- 1、 Removal of the cape
- 2、 Removal of the calf
- 3、 Removal of back cover
- 4、 Removal of the armrest
- 5、 Removal of back frame
- 6、 Removal of mechanism
- 7、 Removal of electric control box
- 8、 Removal of side panel
- 9、 Removal of actuators

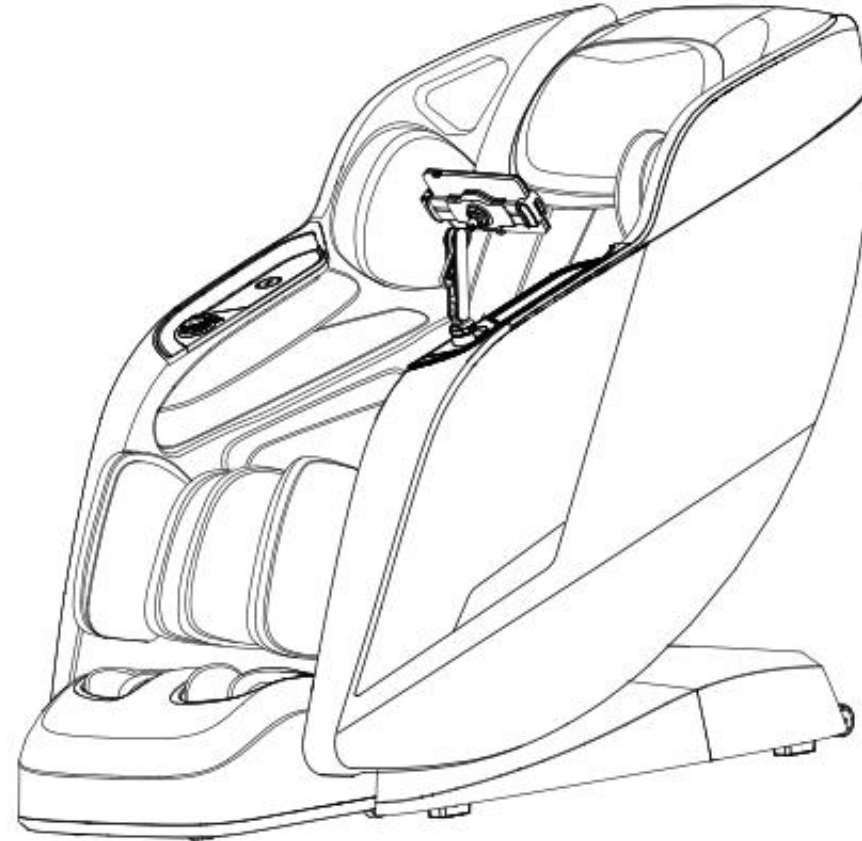

3.2.1·Removal of Calf

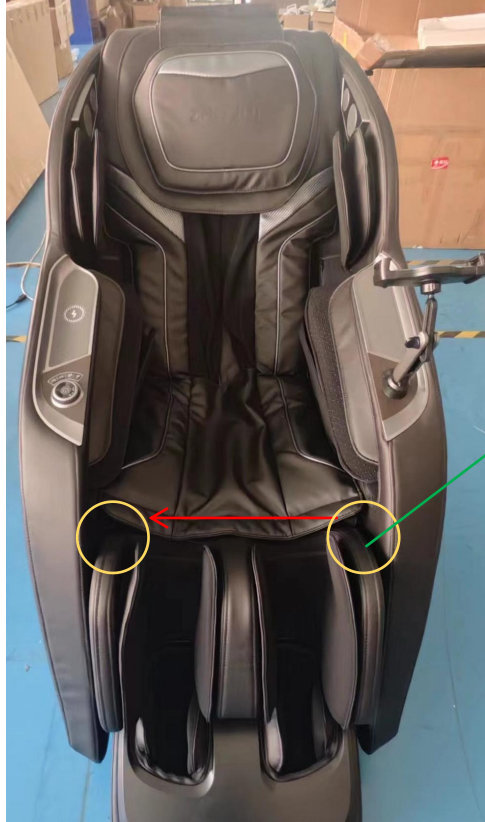

Buckle style

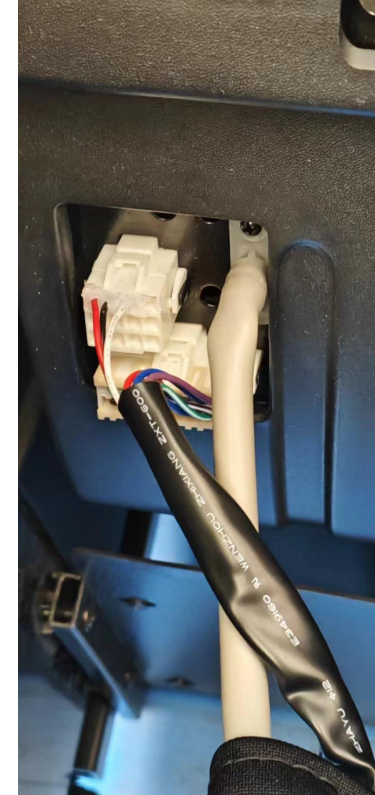

① Unzip the zipper (red arrow); remove the carabiner (yellow circle) and pull and push it outward a little to remove it



② Remove terminals and unplug air tubes

③ Calf part

3.1.1·Removal of the cape



① Unzip the picture and remove the buckle

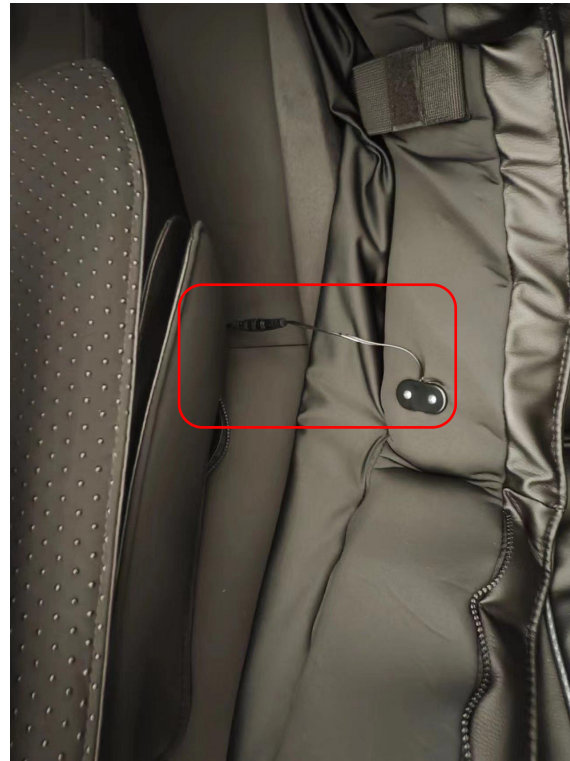

② Unscrew the connection terminals shown in the figure



③ Cape part

3.2.2·Removal of the calf

Decomposition



Remove the seven screws shown above and take off Picture(1)



Screw

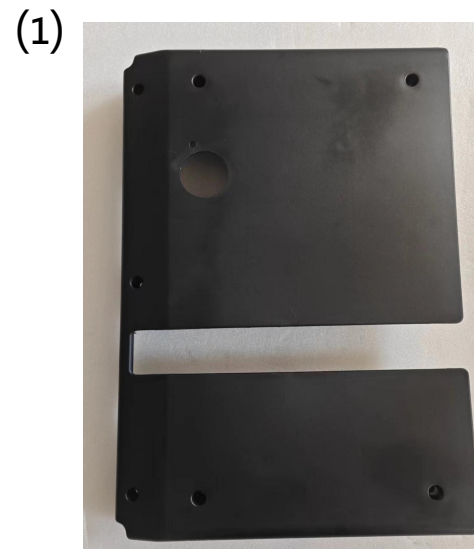

② Remove the eight screws in the figure and take down the picture (2)

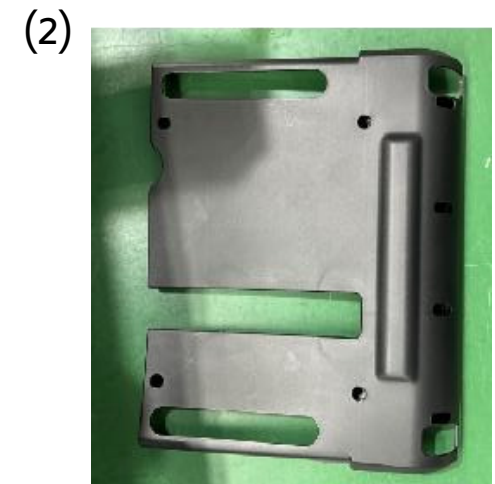

screw

3.2.2·Removal of the Calf

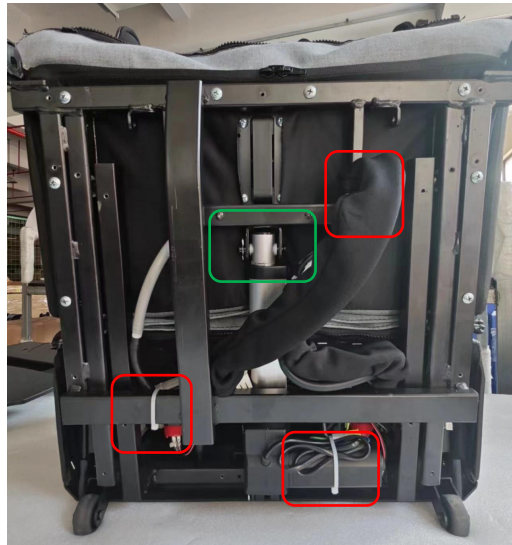

① Cut ties and remove actuator pins



bolt



② Unplug the two air hose connectors and the telescopic actuator connection terminals shown in the figure.

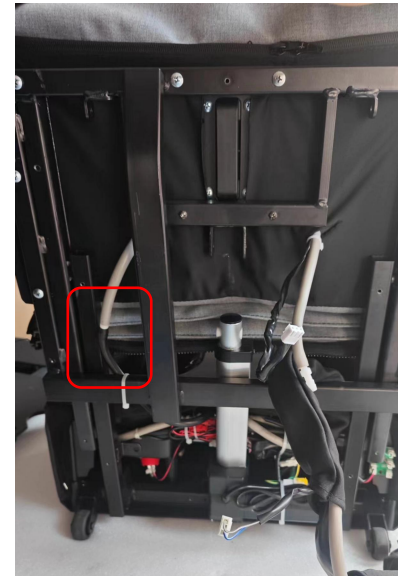

③ Pull up with both hands and unzip the zipper between the upper leg and the foot.

3.2.2·Removal of the calf

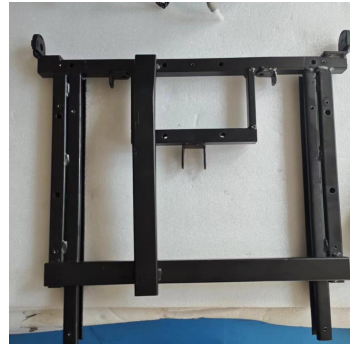
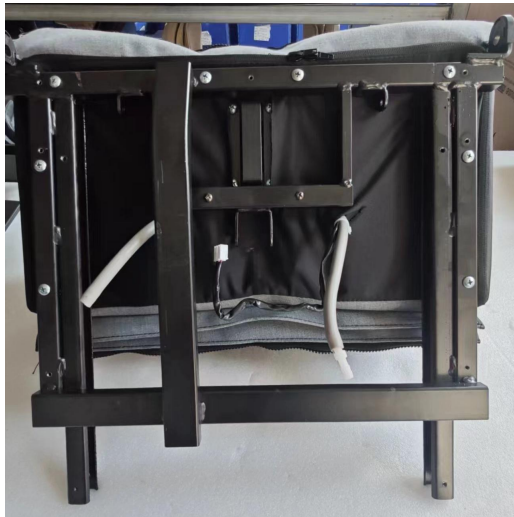

④ the calf part

Remove the screws from the iron frame in the disassembly diagram

screw



⑤ iron stand

⑥ Unzip the zipper in the direction of the arrow in the picture.

3.2.2·Removal of the calf

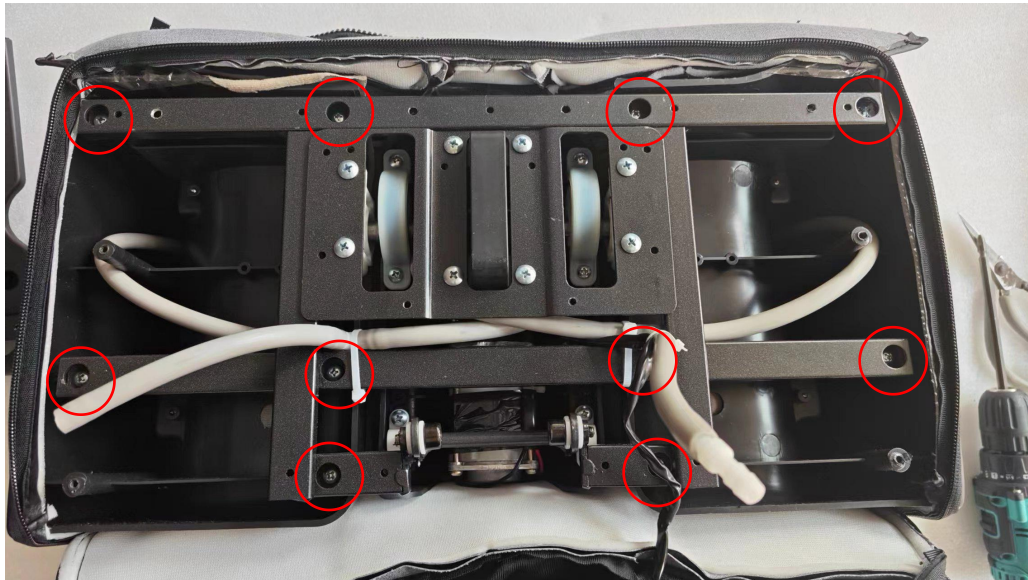

⑦ The internal motor can be removed by removing the screws shown in the figure.



Foot holster



① Unzip the zipper and remove the leg holster

3.2.2·Removal of the Calf

Decomposition

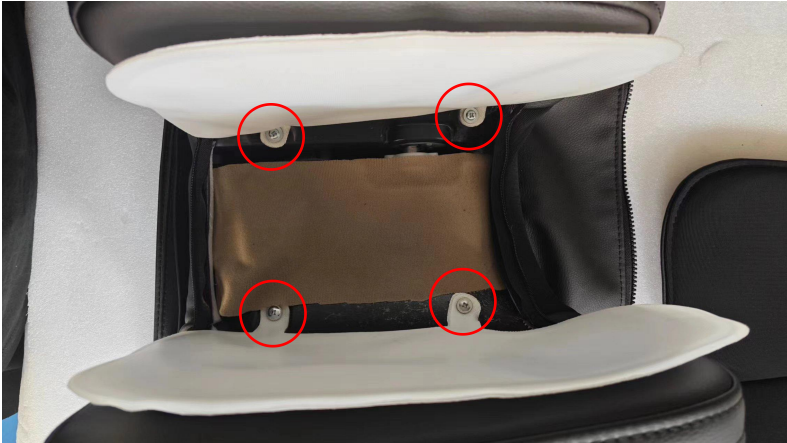

① Remove the screws in the picture to remove the leg airbags

3.2.2·Removal of the Calf

Decomposition

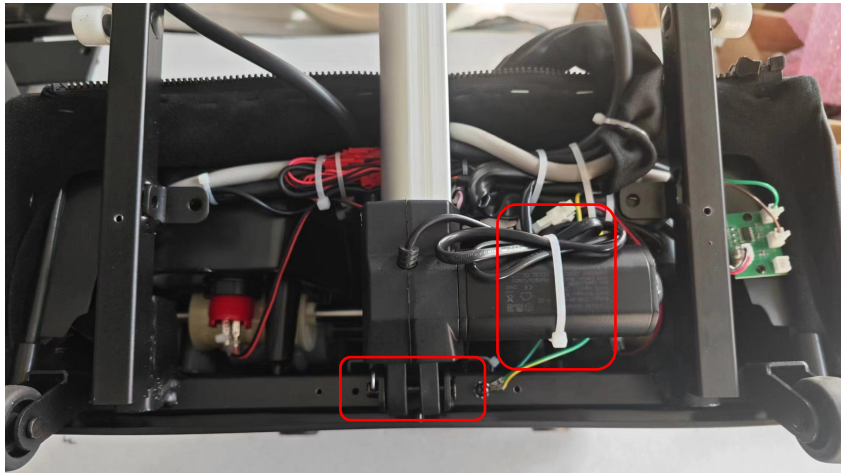

① Cut the cable ties in the picture and remove the latch



② Unplug the terminals and remove the actuator



③ Remove the screws under the foot holster, one on each side.

Screw



3.2.2·Removal of the Calf

Decomposition

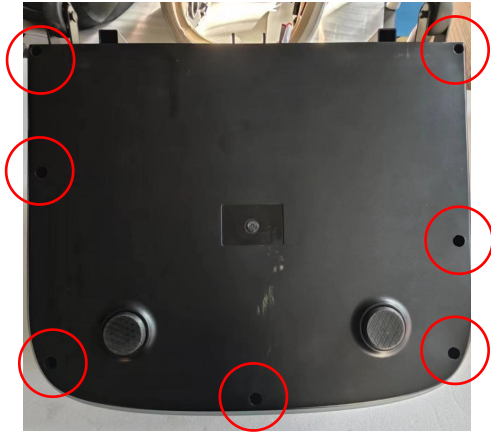

Screw

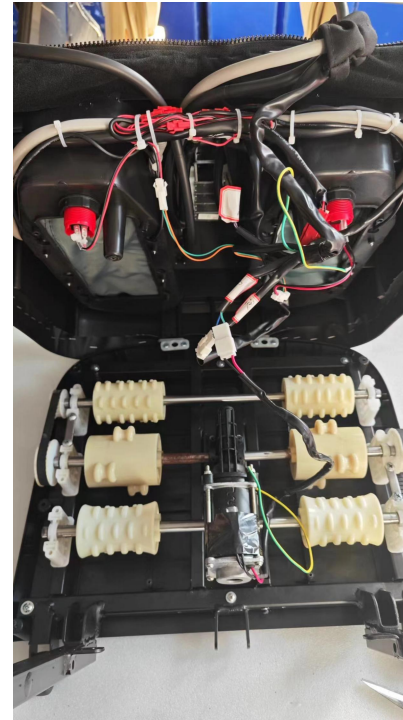

④ Cut the cable ties in the picture and remove the pins

⑤ Separate the bottom of the foot from the cap and unplug the corresponding terminals.

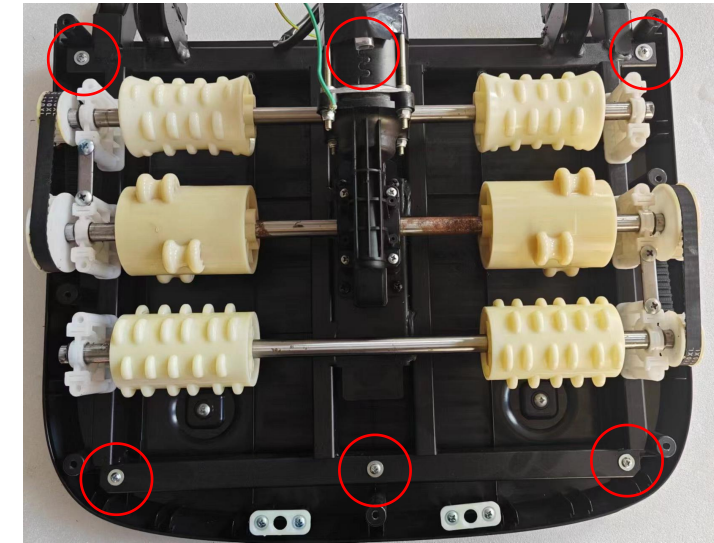

⑥ Remove the six screws (red circles) and separate the bottom cover.

3.2.2·Removal of the calf

Decomposition



screw

⑦ Bottom cover and screw pattern

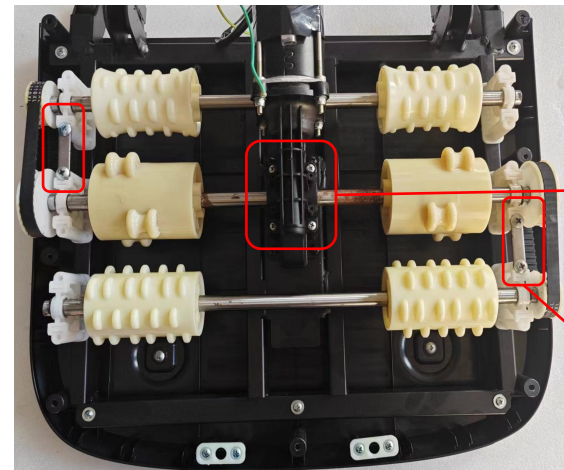

⑧ Remove the screws in the picture, remove the motor and the patch.



3.2.2·Removal of the calf

Decomposition

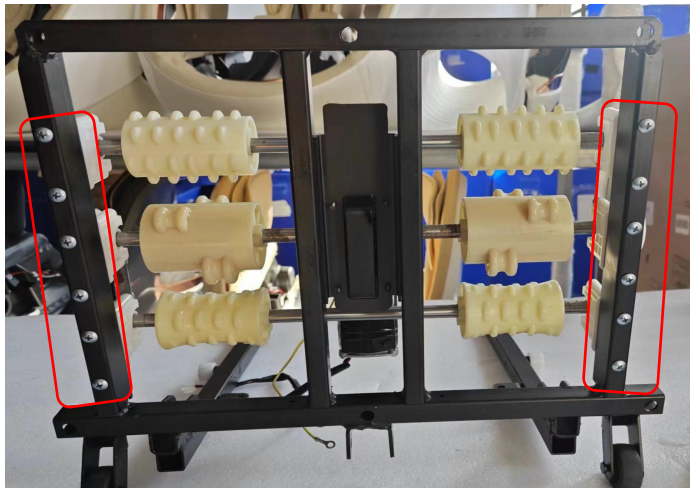

⑨ Bottom cover and screw pattern

screw



belt



foot roller



3.2.2·Removal of the calf

Decomposition

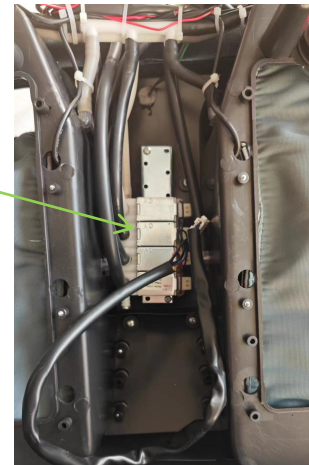
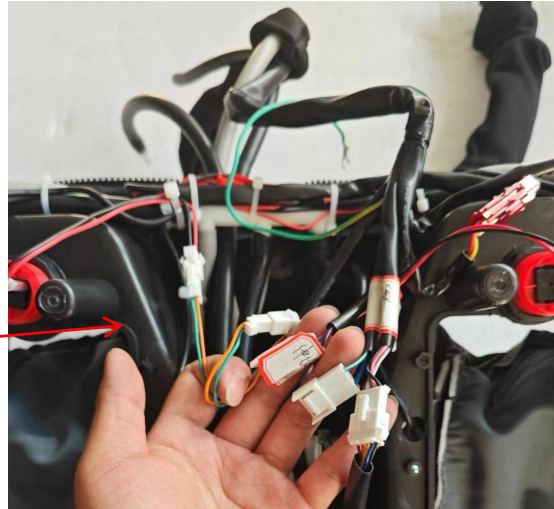
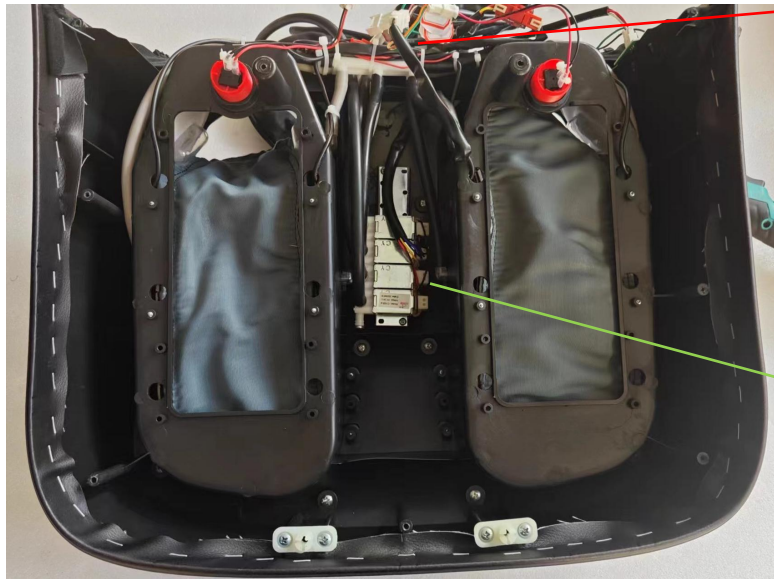

heating pad



① Remove the solenoid valve and heating pad by unplugging the corresponding terminals.

3.2.2·Removal of the calf

Decomposition

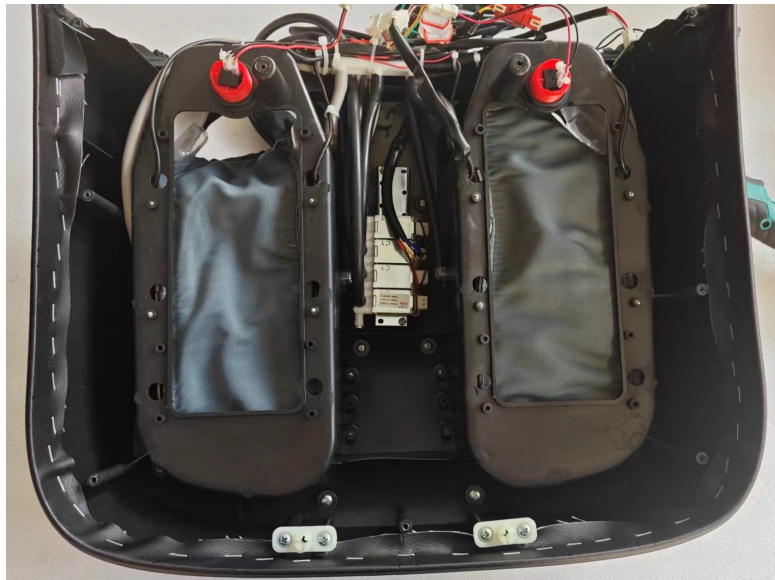

① Remove the foot trim by removing the screws in the picture

Upper Foot Cover



screw



3.3.1·Removal of back cover



① Remove the two screws shown



screw



② Remove the rear shell has a male and female buckle, after removing the screws, pull outward to remove it



③ back cover

3.4.1·Removal of the hand rest



screw

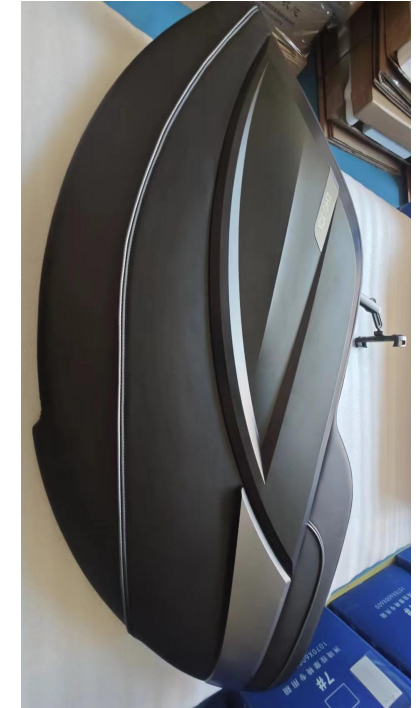

① Remove the screws in the picture with an hex wrench

② Left armrest

注：左右拆卸扶手方法相同

3.4.2·Removal of the hand rest

Decomposition of hand rest decorations

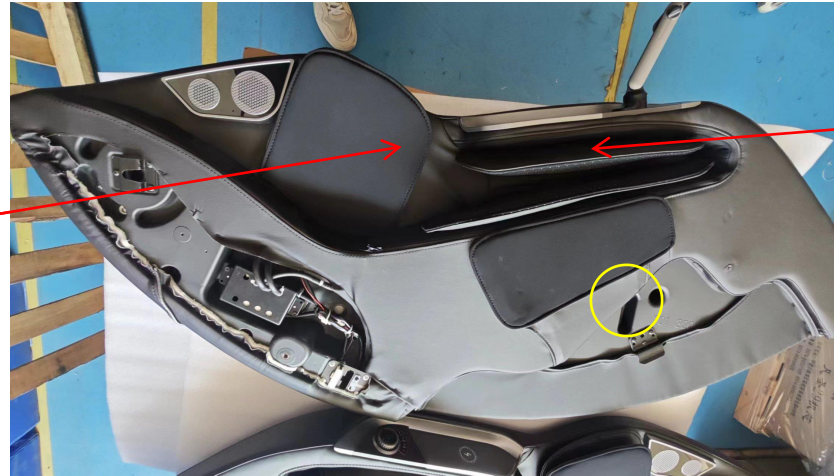

large trim piece



① Remove the four screws shown (circled in yellow) and remove the large trim piece

Note: After removing the screws, you need to break them outward to remove the decorative parts.

3.4.3·Removal of the hand rest

Decomposition of hand rest decorations



① Remove the two screws shown (circled in red) and remove the small trim piece

Small decorative piece

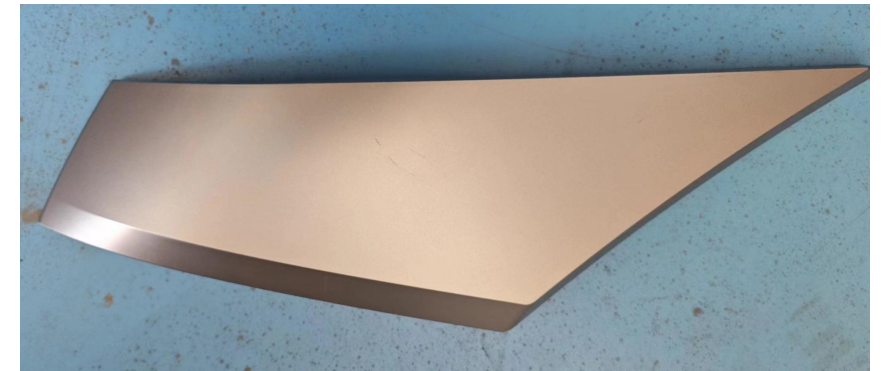

Note: After removing the screws, you need to break them outward to remove the decorations.

3.4.4·Removal of the hand rest

Solenoid valve disassembly



① Solenoid Integration Box
(as shown)

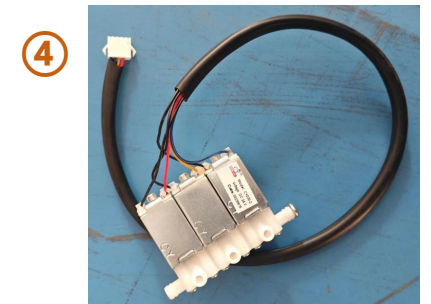
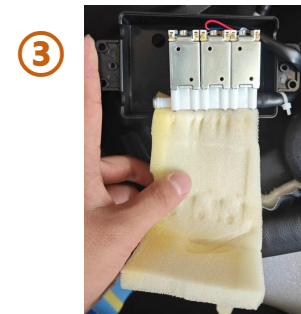
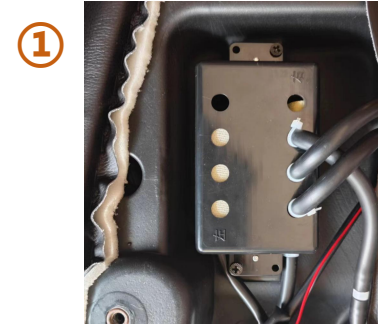

solenoid
valve

Note: Remove the solenoid valve by following the steps above

3.4.5·Removal of the hand rest

speaker removal



① Removal of the black cover plate



② Removal of the black cover plate



③ Speaker components

3.4.6·Removal of the hand rest

Decomposition of armrest panels



① Peel off the screw cover



② Peel off the screws



③ Remove the quick access panel

Note:left panel

3.4.6·Removal of the hand rest

Decomposition of armrest panels



① Peel off the screw cover



② Peel off the screws



③ Remove the shortcut key panel

Note: right panel

3.5.1·Removal of the back frame

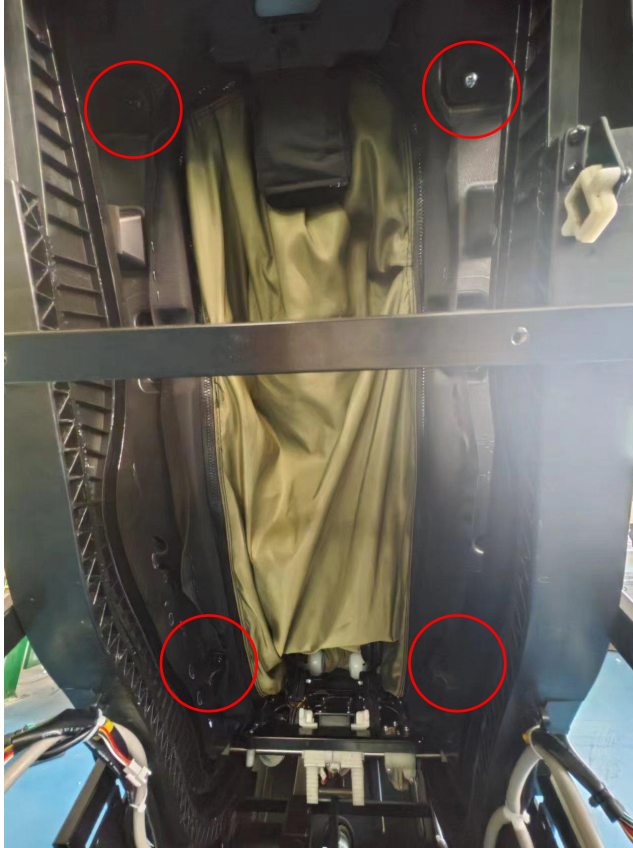

① Remove the four screws shown



② Remove the screws in the picture



③ back frame

3.6.1 Removal of the mechanism

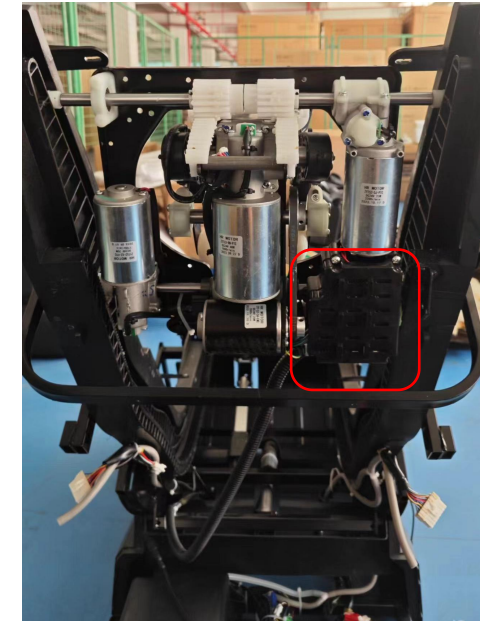
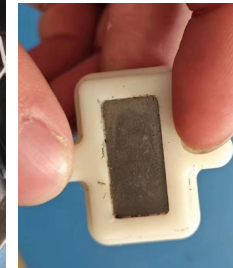
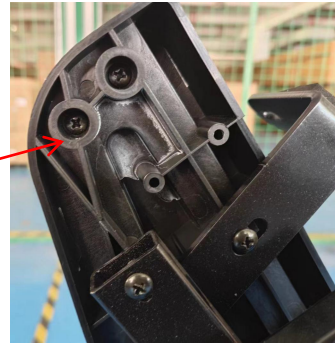
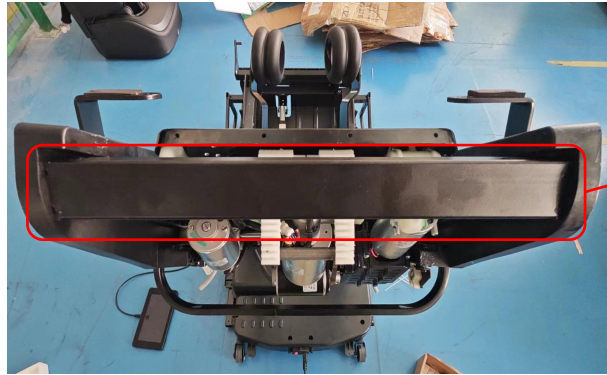

① Remove beams shown

② Remove screws shown (two left and two right)

③ Remove the upper induction magnet

④ Remove the movement connection harness

3.6.2·Removal of the mechanism

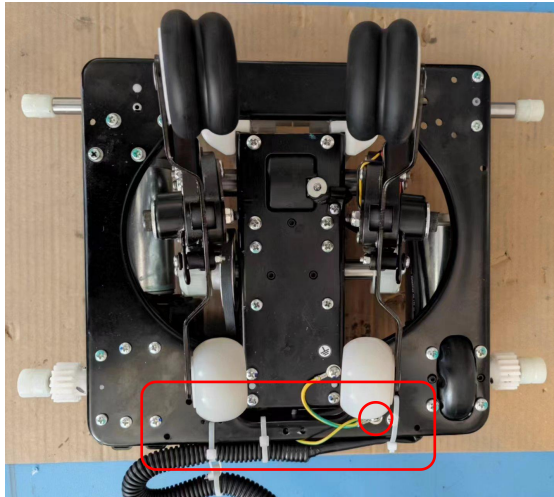

⑤ Cut the retaining tie and remove the ground wire

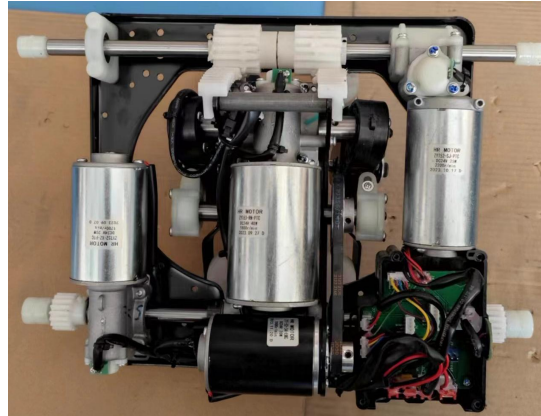

⑥ remove the mechanism

3.7.1·Removal of electric control box



① Remove the four screws shown

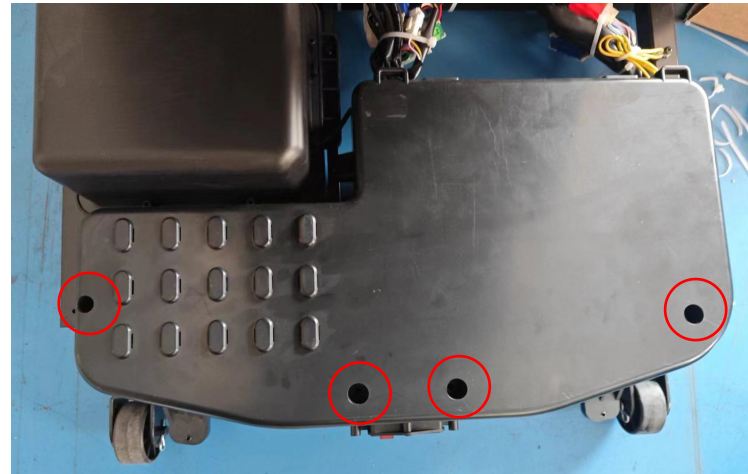

② Remove the four screws shown

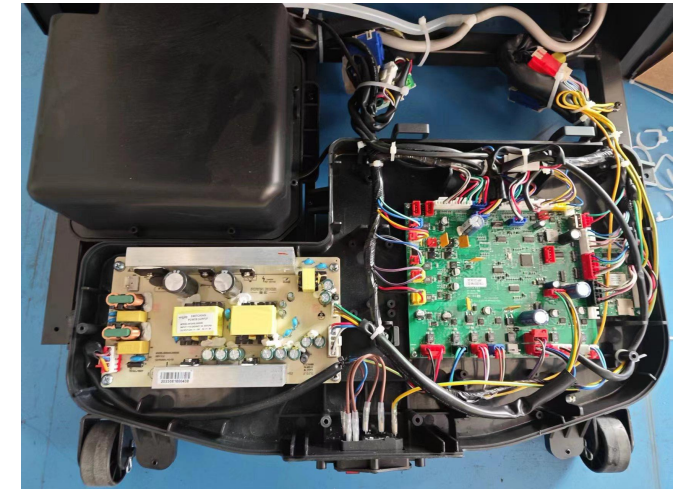

③ Electrical Control Box

3.8.1 · Removal of side panel



① Remove front screw (near calf)



② Remove the middle screw



③ Rear screws (near the electric control box)

Note: To remove the side panels, use the remote control to press the back inverted until the screws can be removed

3.8.2·Removal of side panel



① Right side panel

screw



3.9.1 · Removal of actuators

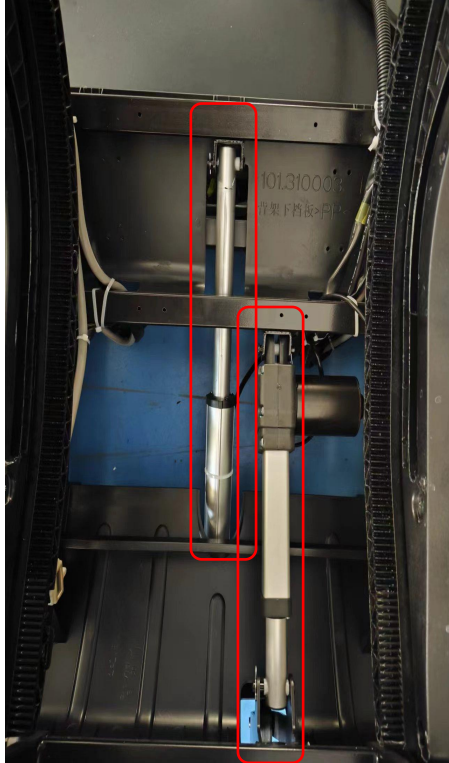

① Remove the inverted backrest putter with the leg lift putter (as shown)



② Remove reverse backrest actuator terminals

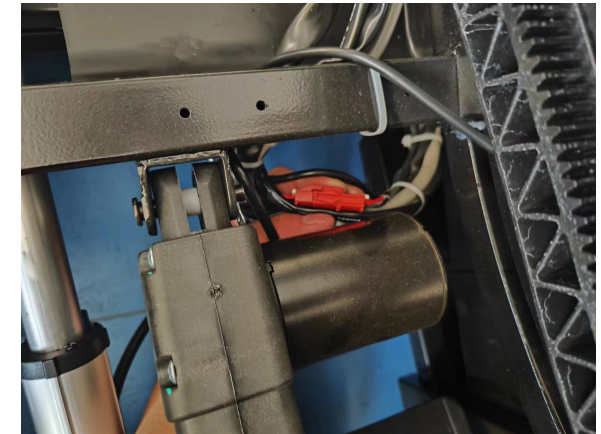

③ Remove legrest actuator terminals

3.9.2·Removal of actuators

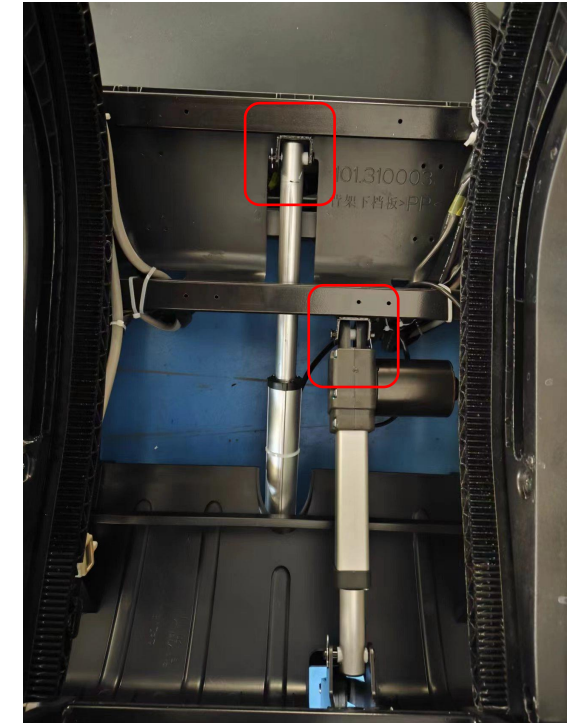

④ Remove the front bezel panel

bolt



⑤ Remove the bolt shown to remove the actuator

3.9.3·Removal of actuators



⑥ Legrest
actuator



⑦ Backrest
actuator

四、Problem analysis and maintenance

1. Hand Controller Fault Code
2. Machine does not work
3. Kneading and tapping does not work
4. Mechanism can not travel up and down
5. Foot roller does not work
6. Foot roller does not work
7. Backrest leg heat therapy does not work
8. No music function
9. A group of air pressure does not work

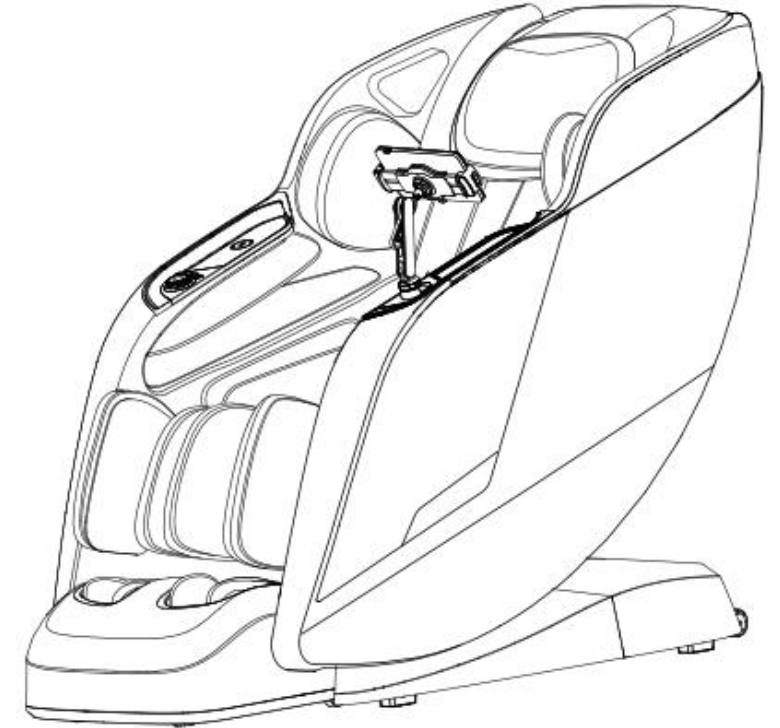

4.1.1·Problem analysis and maintenance

Hand controller fault code

Fault Alarm			
代码	description	possible causes	Checking
1	Button Stuck on the hand controller 01	Button Stuck	check the keys
2	Timeout between main control board and hand controller Main--Ctrl Link	Bad or broken wiring	check the wiring

4.2.1·Problem analysis and maintenance

The whole machine does not work

Analysis

1. The main switch is not on (I on and O off), make sure the power cord is plugged in.
2. The hand controller itself is damaged, resulting in failure to start, using the replacement method to eliminate.
3. If The fuse is blown, it is usually caused by the short-circuit of the driver due to the load; replace the load, the main board and the fuse.
4. The connecting wire behind the switch assembly is loose or broken.
5. Check whether or not the switching power supply board has DC 24V power output. If the power output indicates that the motherboard is damaged, replace the motherboard, and if no power output, replace the switching power supply board.

4.3.1·Problem analysis and maintenance

Kneading and tapping doesn't work

Analysis

1. Use a multimeter to measure the red plug-in in the red circle on the mainboard and check whether there is voltage DC24V output, if not then replace the motherboard. If there is voltage, check whether the wire harness plug-in has poor contact, and whether the motor has any resistance.

2. If after confirming the main board voltage, harness plug-in and wiring harness good, kneading motor still does not work, replace the motor.

3. In the absence of a multimeter, you can use the substitution method to confirm that the motor is good or bad, (kneading and tapping plug-in interchangeable).

4.4.1·Problem analysis and maintenance

The mechanism can't walk up and down

Analysis

1. First of all, make sure to check the wiring harness to see if there is any poor contact plug-in off phenomenon.
2. Measure the yellow plug-in of the main board with a avometer, as in Figure 1, to check whether there is DC 24V voltage output. If no, replace the main board.
3. In the case of confirming the voltage, use the multimeter to measure whether the motor has resistance value, and replace the motor without resistance value to eliminate the fault.
4. When no multimeter can be used to confirm the motor is good or bad, (walking and kneading, beating plug-in exchange).
5. On the condition of confirming the wiring harness, power supply and motor good, if the mechanism still does not walk, replace the internal circle count board of the mechanism, then change the upper and lower limit detection board or mechanism components as in picture 2

4.5.1·Problem analysis and maintenance

The backrest or legrest does not rise or fall

Analysis

1.First check whether the wire harness of the actuator has bad contact with the plug off.

2.Press any key of the hand controller by the actuator, and use the avometer to measure the power supply plug-in on the mainboard. If there is DC24 output, replace the actuator. If there is no voltage output, replace the mainboard.

3.Without avometer, the plug-in swap exclusion method can be used to troubleshoot. Figure 1

4.If the backrest and legrest actuators do not rise or fall at the same time, first check whether the anti-pinch induction switch on the back cover of the electric control box is controlled, and then check whether the plug-in wire harness of the anti-pinch induction detection board is in bad contact or falls off. If the anti-pinch induction detection board and the main board are well replaced, the fault can be eliminated. Figure 2

4.6.1·Problem analysis and maintenance

The foot roller is not working

Analysis

1.First check whether the wiring harness has bad contact plug-ins off

2.Turn on the manual controller to open the instruction, and use the multimeter to measure the plug-in on the mainboard.

3.Without avometer, the substitution method can be used to confirm the quality of the motor (roller motor and kneading, beating plug-in exchange).

4. In the case of confirming the voltage on the main board, use the avometer to measure whether the motor has resistance value, and replace the motor without resistance value to eliminate the fault.

4.7.1·Problem analysis and maintenance

Backrest and leg heating do not work

1.First check whether the wiring harness has bad contact plug-ins off

Analysis

2. Find the mainboard thermotherapy plug-in to open the hand control command, and use the avometer to check whether there is voltage output. If there is no voltage output, replace the motherboard, and if there is, replace the thermotherapy device.

4. 8. 1 • Problem analysis and maintenance

When no music

Analysis

1. First check whether the wiring harness has bad contact with the plug off phenomenon.
2. Check whether the mobile phone Bluetooth is connected to the massage chair
3. If Bluetooth cannot be searched, replace the Bluetooth version









4. 9. 1 • Problem analysis and maintenance

When the airbag doesn't work

Analysis

1. First check whether the air bag is damaged or leaking, whether the air pipe is bent or broken, and whether the air is leaking.
2. Check whether the wiring harness connection plug-in is loose and whether the wiring harness is broken.
3. Use the avometer to confirm whether the air pump has DC24V voltage, no replacement of the motherboard, if there is replacement of the air pump.
4. Use the avometer to confirm whether the group of solenoid valves are normally supplied with DC 24V. If there is no voltage to replace the motherboard, the fault can be eliminated, if there is voltage to replace the solenoid valve.

五、Tool List

							
Avometer	Test pen	Hex wrench	Nose pliers	PVC tape	Cable tie	Vice	Electric hand drill



Thank you

Customer Service