

# Grand duo (RK8601) Service Manual



# Catalogue

I. Product components: .....	1
1. RK8601 structure diagram.....	1
2. Introduction of key components .....	3
II . Common Failures and Solutions.....	5
1. The massage chair does not work, and the controller does not display.....	9
2. The massage machine and the stay bar don't move, other functions are normal, and the hand controller displays.....	10
3. Abnormal up-down movement of massage mech .....	10
4. Abnormal kneading of massage mech.....	15
5. Abnormal tapping of massage mech .....	16
6. Massage mech leans forward abnormally.....	19
7. All airbags do not inflate or just one way airbag does not inflate.	21
8. Back actuator is abnormal .....	23
9. Leg actuator is abnormal.....	25
10. Foot rollers do not work. ....	26
11. Leg rubbing motor does not work.....	27
12. Telescopic motor works abnormally.....	28
13. Leg heating cloth does not work. ....	30
14. Foot heating cloth does not work. ....	30
15. Shawl heating cloth does not work.....	31
16. Abnormal physiological detection function .....	32
17. The horn doesn't ring and the voice is abnormal. ....	33

---

18. Negative ions do not work. ....	34
19. Aromatherapy doesn't work .....	34
20. Abnormal charging .....	35
21. Abnormal shoulder height detection.....	38
22. Abnormal heating of mech.....	39
23. LED strip works abnormally .....	39
24. Armrest closing signal is abnormal .....	41
25. Abnormal tablet control.....	42
III . Mechanical failures and solutions: .....	44
1. Replace the massage mech assembly .....	44
2. Remove armrest assembly and shoulder.....	45
3. Remove the plastic body assembly of the front backrest.....	56
4. Remove the power box assembly.....	57
5. Dismantle the leg-rest .....	57
6. Remove the backrest brace and leg brace assembly.....	62
7. Remove the solenoid valve assembly of backrest frame.....	64
8. Adjust the gap between handrail assembly and shoulder.....	65
9. Maintenance massage machine assembly .....	66
10. Replace air pump assembly. ....	69
IV . Main circuit board component layout .....	71
V. System Connection Diagram .....	72

# I. Product Components:

## 1. RK8601 structure diagram

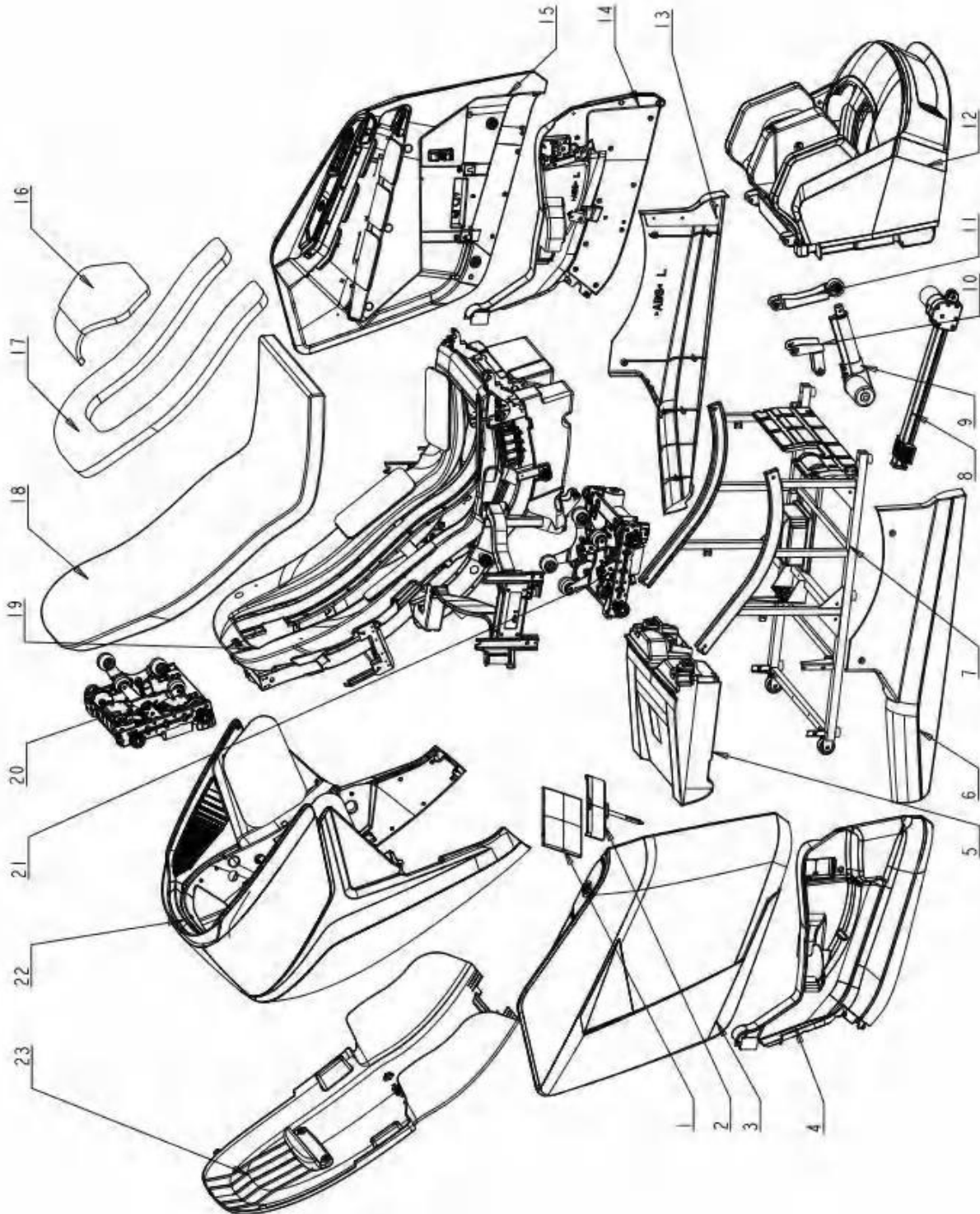

### Mechanical Components List

NO	NAME	PIECE	NO	NAME	PIECE
1	CMD Tablet Controller	1	22	Shoulder cushion	1
2	Tablet Bracket Assy	1	23	Backrest Cover	1
3	Right Armrest Assy	1			
4	Right Lower Guard Assembly	1			
5	Power Box Assy	1			
6	Right Fender	1			
7	Seat Frame Assembly	1			
8	Seat Actuator	1			
9	Leg and Foot Electric Support Rod	1			
10	Actuator Split Ear Seat Component	1			
11	Legrest Actuator	1			
12	Leg and Foot Assembly	1			
13	Left Fender	1			
14	Left Lower Guard Assembly	1			
15	Left armrest assembly	1			
16	Pillow Assembly	1			
17	Shawl Assembly	1			
18	Back Seat Cushion	1			
19	Back-rest Assy	1			
20	Upper Mech	1			
21	Lower Mech	1			

## 2. Introduction of key components



Main circuit board

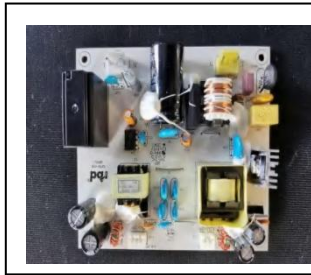

power panel

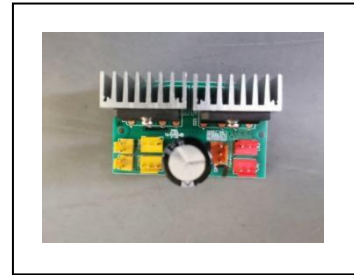

Rectifier plate



Filter

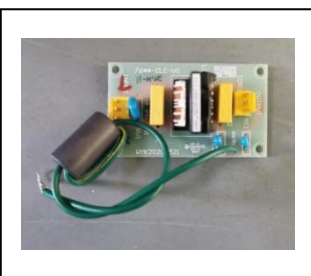

Filter plate

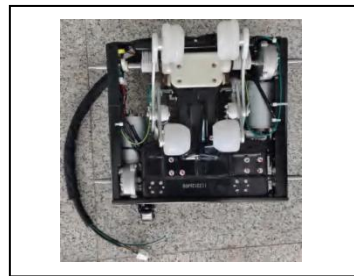

Upper massage machine assembly



Lower massage machine assembly



Leg brace

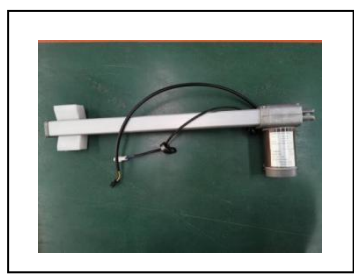

Back brace



Ring transformer



air pump

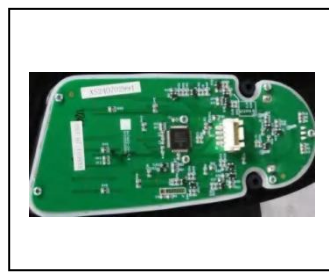

Simple manual control board



Voice board

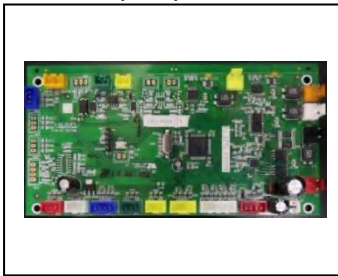

Upper core plate

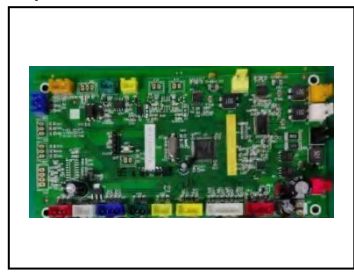

Lower core plate

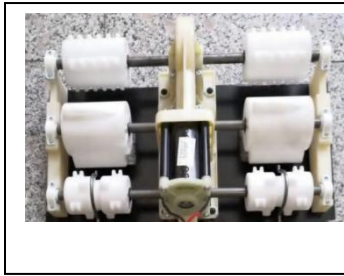

Roller assembly



Aromatherapy fan

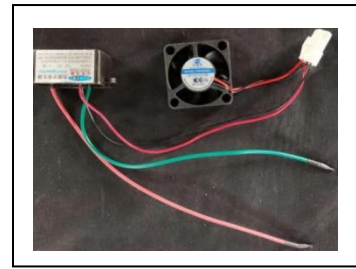

anion

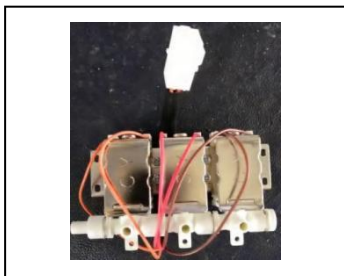

Seat solenoid valve

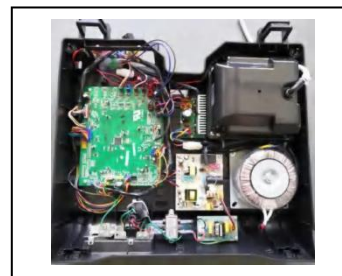

Power box assembly

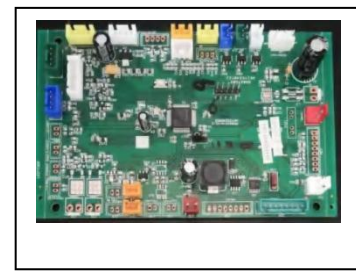

Right armrest plate assembly

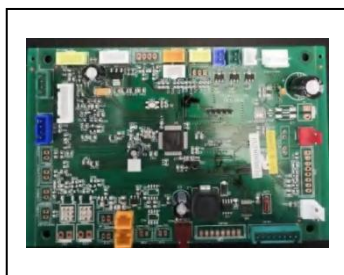

Left armrest plate assembly



Wireless charging module

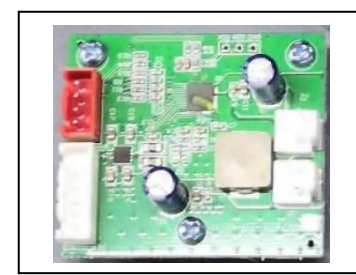

Fast charging module



Leg board



Physiological detection module



trumpet

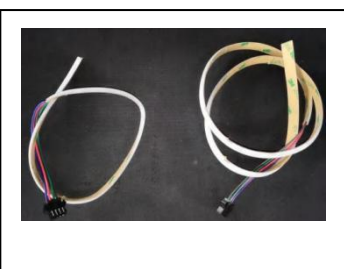

Shoulder light strip

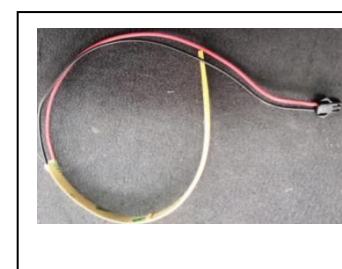

Handrail logo light belt

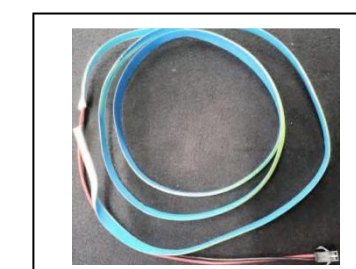

Handrail lower light belt

## Second, the common faults and solutions

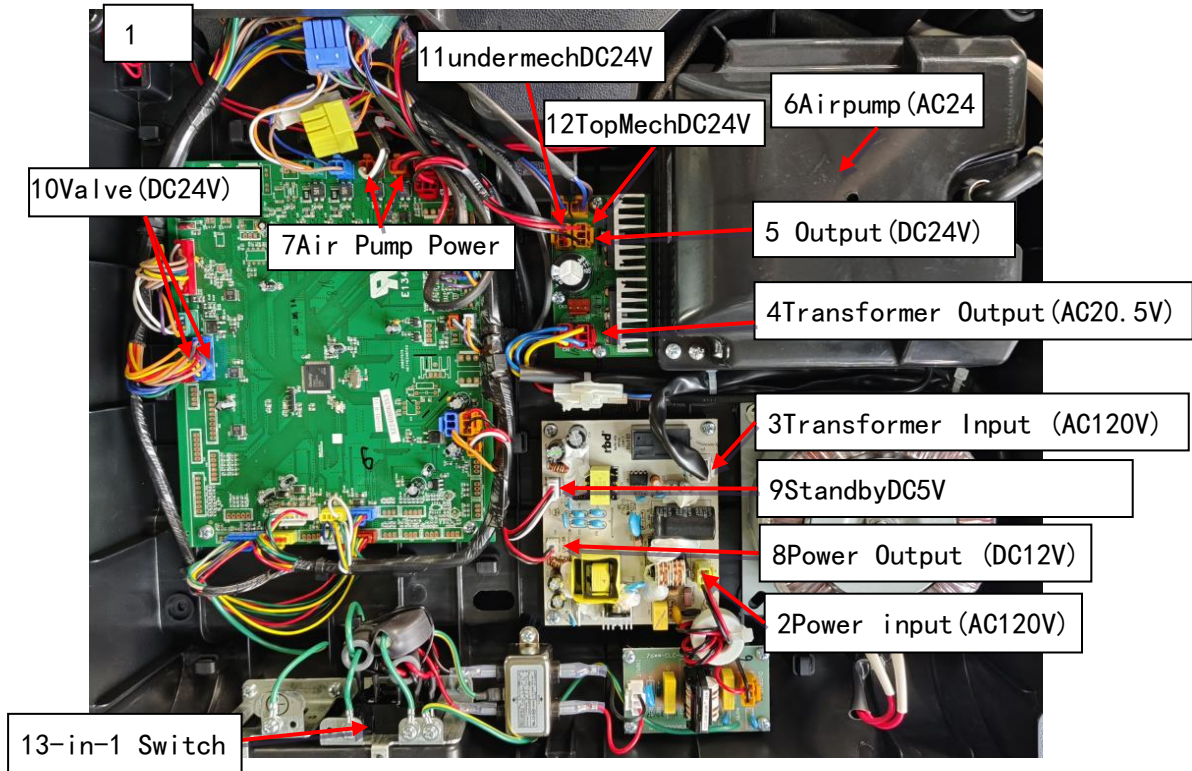

### Electrical connection diagram

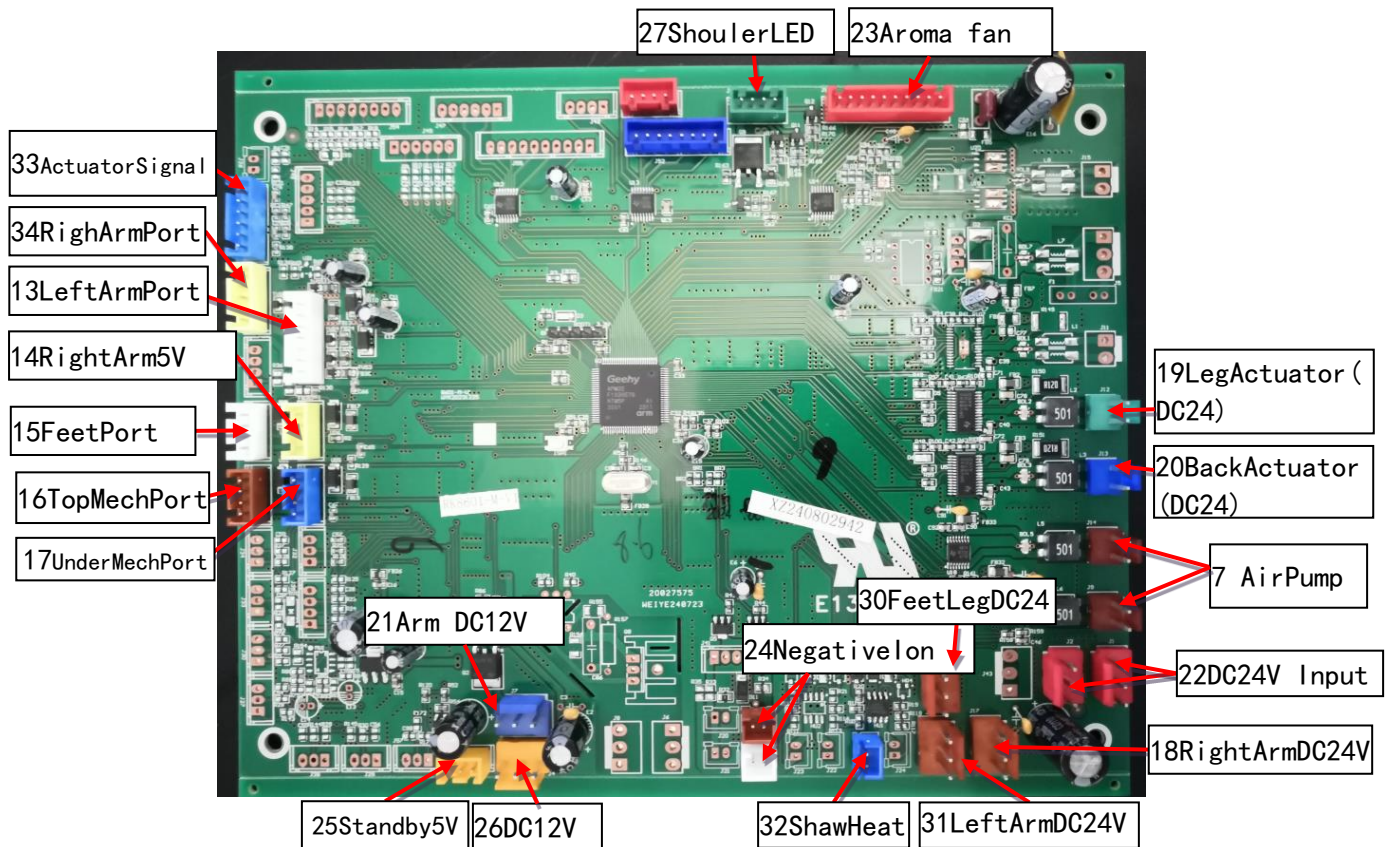

Electrical connection diagram of upper and lower machine core circuit boards (the ports are the same, and the lower machine core is not heated)

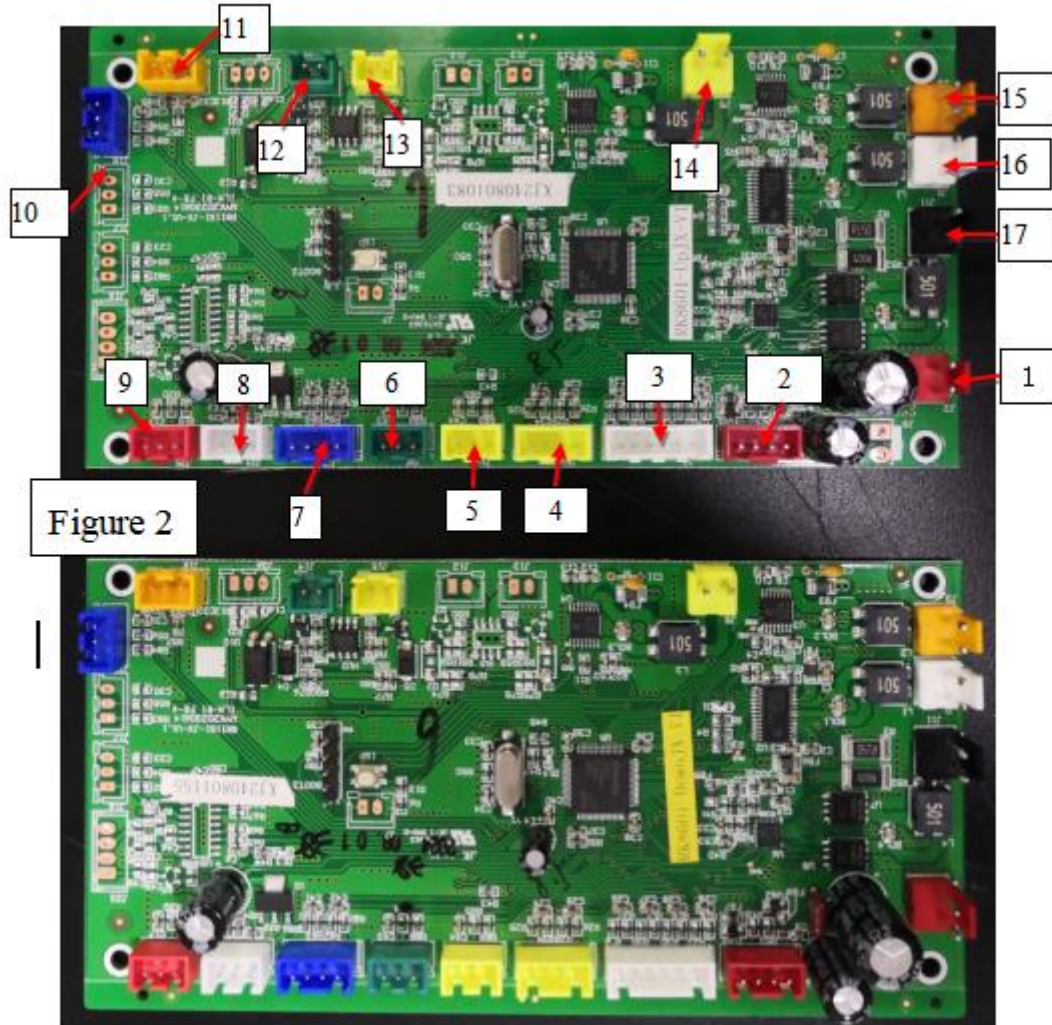
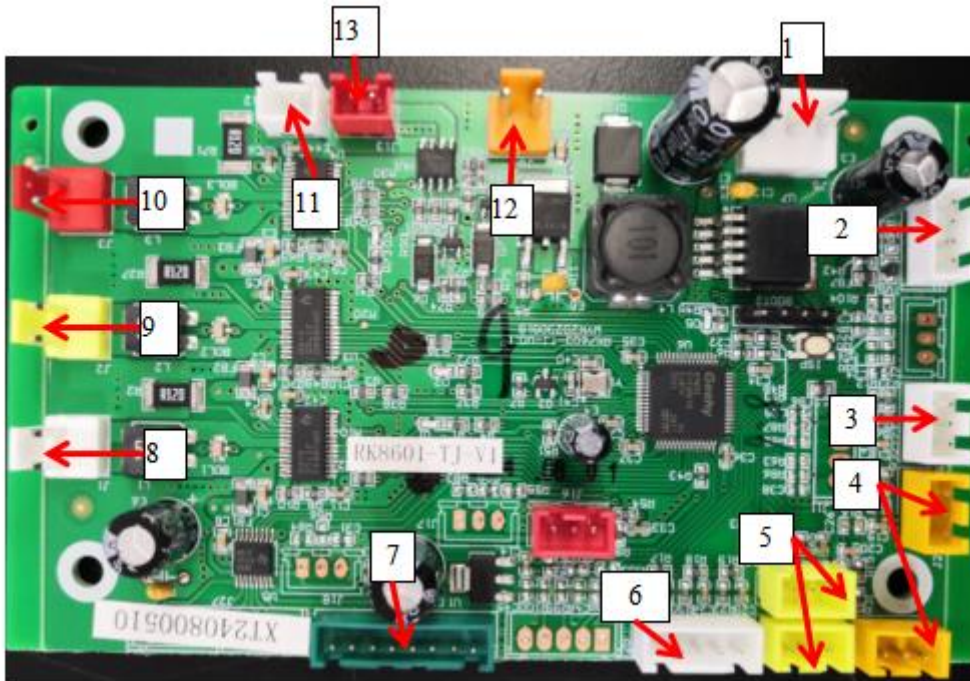

Figure 2

1	Mainboard DC24V	10	Upper Right Wheel Signal
2	Mechanism Serial Port	11	Upper Left Wheel Signal
3	Wide-Medium-Narrow Signal	12	Upper Right Wheel Heating
4	Forward Tilt Limit	13	Upper Left Wheel Heating
5	Lifting Count	14	Forward Tilt Motor
6	Forward Tilt Count	15	Lifting Motor
7	Lifting Limit	16	Knocking Motor
8	Anti-collision Switch	17	Kneading Motor
9	Kneading Count		

### Electrical Connection Diagram Of Legrest PCB



1	Power Supply	8	Leg rubbing motor
2	Serial port	9	Roller motor
3	Ground collision detection	10	Extension & retraction motor
4	Leg length detection	11	Leg Heat
5	Anti-pinch	12	12V light strip
6	Extension & retraction counter	13	Foot Heat
7	Solenoid valve	14	

### Electrical Connection Agram Of Right Armrest Circuit Board

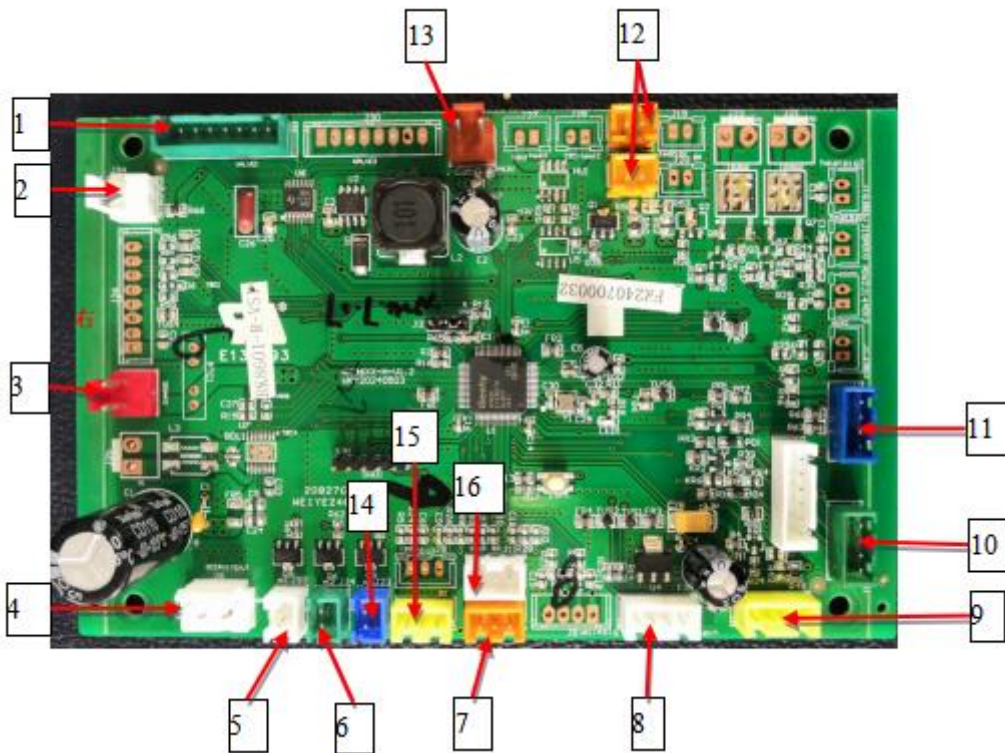

1	Solenoid Valve	9	Voice Board Serial Port
2	Mainboard Power DC12V	10	Physiological Serial Port
3	Charging DC24V	11	Bluetooth Serial Port
4	Mainboard Power DC24V	12	LED Light Strip
5	Physiological Detection LED	13	Voice Board Serial Power
6	Door Close LED	14	Door Open LED
7	Tablet Control Charger	15	Door Lock Switch Signal
8	Mainboard Communication Serial Port	16	Mainboard Power DC5V

### Electrical Connection Diagram Of Left Armrest Circuit Board

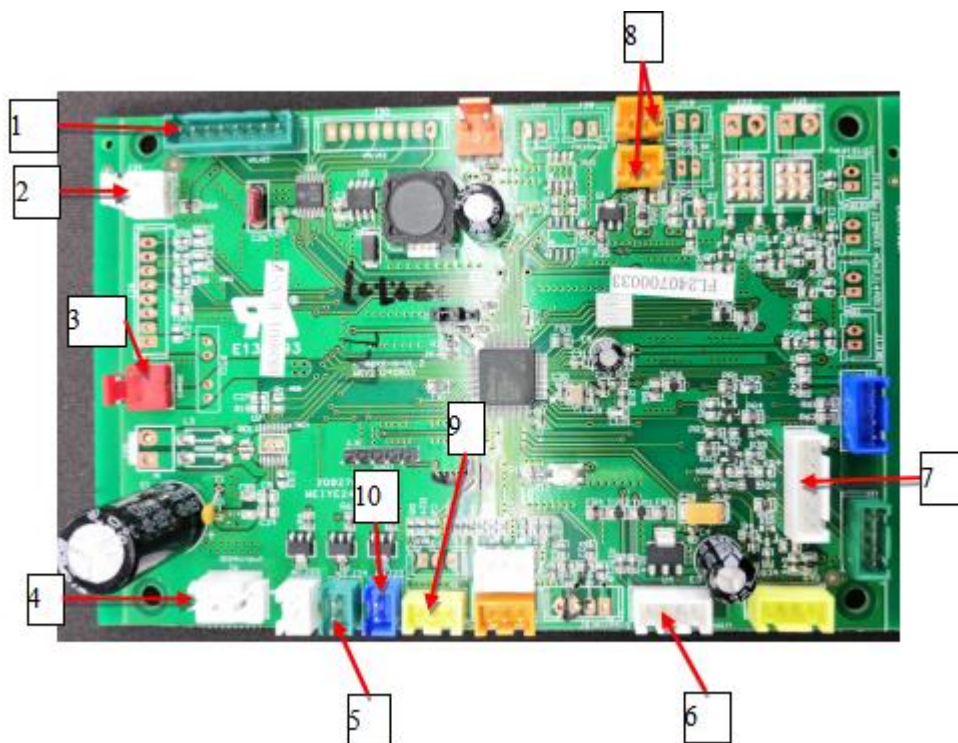

1	Solenoid Valve	6	Mainboard Communication Serial Port
2	Mainboard Power DC12V	7	Shortcut Panel
3	Wireless Charging DC24V	8	LED Light Strip
4	Mainboard Power DC24V	9	Door Lock Switch Signal
5	Door Close LED	10	Door Open LED

**1. The massage chair does not work, and the hand controller does not display.**

1.1 First, check that there is electricity in the socket. Turn on the switch of the 3-in-1 switch base, and judge whether the fuse of the 1-in-1 switch in Figure 1 is blown, if the fuse is burnt and replaced, it will be normal.

1.2 Measure the voltage at the power input (AC120V) of the second power supply with the multimeter AC voltage range. If the voltage is abnormal, check whether the filter and filter board are faulty and whether the connection is normal; If it is abnormal, it can be replaced.

1.3 Use the multimeter DC voltage range to measure whether the voltage at 25 standby and DC5V(DC5V) is normal. If there is no voltage, check whether the connecting wire between the power board and the motherboard is in good contact. If there is no problem, it should be that the power board is broken and normal after replacement. If 5V is normal, power on and measure whether the standby (white and black lines) voltage is high (DC5V). If it doesn't change all the time, the motherboard is broken and can be replaced;

1.4 Measure 3 transformer input (AC120V) and 4 transformer output with multimeter AC voltage range.

(AC20.5V) Two voltages, if 3 voltages are normal and 4 voltages are not, the ring transformer is broken, and it is normal after replacement. Otherwise, replace the power board.

- 1.5 Flat panel does not display. Press the tablet power-on key to see if it can be turned on normally. If it can't be turned on, charge the chair for a period of time, and then press the turn-on key. If it can be turned on, the battery will be short of electricity and fully charged. Otherwise, replace the flat plate.
- 1.6 The simple hand controller does not display and does not work. Measure whether there is DC5V voltage at both ends of the connector of simple hand controller with a multimeter DC voltage range. If there is, replace the assembly of simple hand controller. Check whether the wiring harness and connector connection of the simple hand controller on the left armrest plate 9 in Figure 5 are normal. If it is abnormal, replace the simple manual cord assembly.
2. **The upper and lower massage machines and struts do not move, other functions are normal, and the simple hand controller displays.**
  - 2.1 Measure whether the voltage at the DC24V input at the motherboard 22 is positive or not with a multimeter DC voltage range. Normally, if there is no voltage, measure whether there is about DC24V output from the output of rectifier board 5, and replace the wiring harness if there is;
  - 2.2 If there is no voltage output, measure the transformer output (AC20.5V) with AC equivalent. If there is voltage, the rectifier board is broken and normal after replacement.
3. **The massage machine moves abnormally (the upper and lower movements are checked in the same way, and the upper movement is heated).**
  - 3.1 When the massage machine works in the up-down state, the massage machine does not move up and down;

3. 1. 1 Turn on the manual control of the tablet manual controller to make the upper massage machine run the whole instruction, and measure whether there is voltage output (about DC24V) at 15 connectors in Figure 2 of the movement board with the multimeter DC voltage range. If there is no voltage, the movement board is broken and normal after replacement;

3. 1. 2 If the voltage is normal, unplug the connector and use the multimeter buzzer to measure the connection and disconnection of the red and black wires from the movement board to the white three-core 450B connector of the lifting motor, and check whether the docking connector is firm and the terminals are in good contact. If all the connections are normal, it means that the lifting motor is broken and the lifting motor or movement needs to be replaced. If the two wires are not connected, it is necessary to replace the docking harness;

3. 1. 3 To judge whether the lifting motor is damaged, put the multimeter in the resistance range, and measure whether the resistance at both ends of the lifting motor connector is 5-30Ω. If it is not, it will be damaged if the resistance is too large.

3. 2 When the massage machine works in the up-down state, if there is a phenomenon of top rushing or bottom rushing (over the limit); The up-down limit signal of the lifting motor is faulty.



3. 2. 1 Check the connector of 7 lifting limit in Figure 2 of the movement board to the red box on the right. Whether the connectors on the middle, upper

and lower limit plates have fallen off and whether the connector terminals have fallen off.

3. 2. 2 Measure whether there is DC5V at both ends of the red frame connector on the right. If it is normal, check whether there is any high-low level change in the lifting limit Hall element (use magnetic steel to approach or leave the Hall element, and measure the red frame.Upper limit or lower limit connector pins 2 and 3), if there is no level change in pins 2 and 3, replace the lifting limit plate.

3. 2. 3 Unplug the connectors at 7 places in Figure 2, and measure the connection and disconnection of the wire harness between the movement board and the upper and lower limit boards with the buzzer of multimeter. If they are all connected, it means that the movement board is broken and can be replaced. If it doesn't work, replace the corresponding lifting limit harness.

3. 3 If the massage machine does not work in a certain area of the shoulder or back, the massage machine runs.Whole journey; Then the signal at the 5-up/down count in Figure 2 of the movement board is faulty.

3. 3. 1 Check whether the connector from the movement board to the limit board of the forward tilting motor falls off and whether the terminal falls off. Unplug the signal input line on the limit board of the forward tilting motor as shown in the

figure on the right, and measure the on-off conditions of the movement boards 4, 5, 6 (red, brown, orange, yellow, blue and black) corresponding to red, brown, orange, yellow and black. If it fails, replace the forward tilting signal harness.

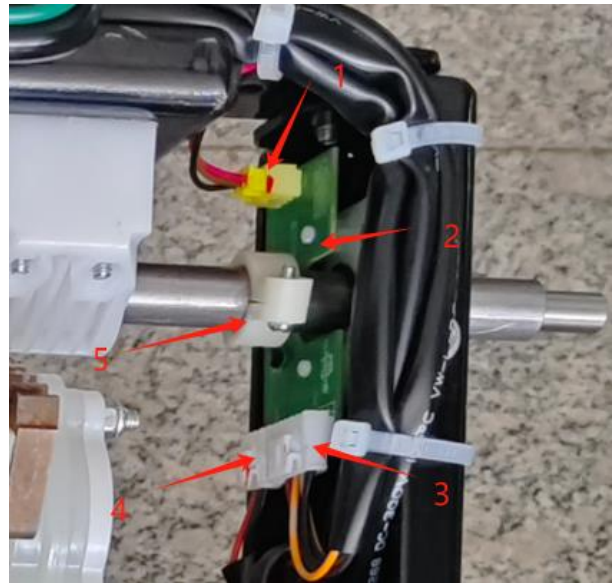

1	Magnetic Steel Induction Plastic Parts	4	Lifting Counter Signal
2	Forward Tilt Counter Signal	5	Signal Input
3	Forward Tilt Motor Limit PCB		

3. 3. 2 If they are all connected, make the massage machine work in the up-down state, and use the multimeter DC voltage range to measure whether the red and black wires of the signal input of the forward-leaning limit plate in the above figure have DC5V voltage, if not, the movement plate is broken, if so, measure whether there is high-low level change between the brown and black lines of the lifting counting signal, if not, the lifting motor is broken and replaced; During the maintenance, do not adjust the positions of the magnet steel of the magnet steel induction plastic parts and the Hall element of the limit plate of the forward tilting motor, otherwise it will also cause the movement to count up and down or

forward tilting.

3.4 When the machine is turned on and enters a program, the massage machine (upper movement) starts to detect the shoulder height. If the massage machine directly moves slightly at the upper limit, it will stop, indicating that the shoulder height detection is faulty. Check the lifting motor, replace the lifting motor and test the shoulder height function. If it is abnormal, replace the movement board.

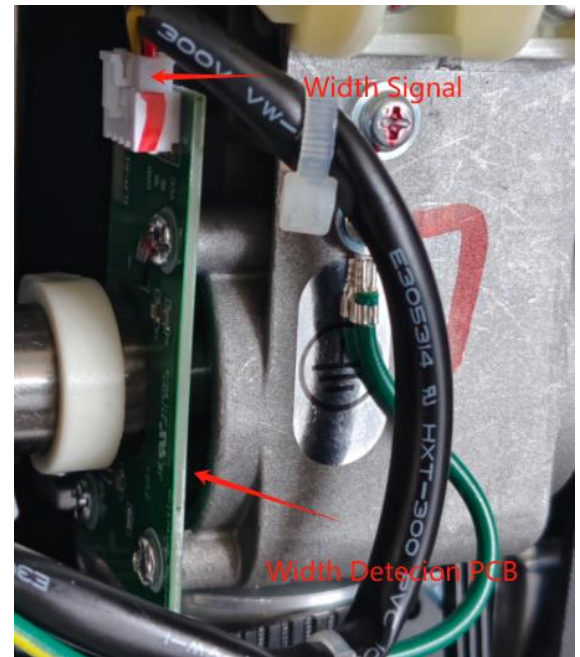

Check the shoulder press Check the lifting motor in the high detection abnormality step. If the massage machine can't detect the shoulder when detecting the downward movement, first check whether the movement is in a wide position; if it is not, and the magnet is installed normally, replace the width detection board (check according to the step of tapping abnormally); Then check whether the forward leaning motor extends normally. If not, check the forward leaning function according to the abnormal steps of the forward leaning motor of the massage machine.

3.5 The anti-collision switch is abnormal. Between the upper and lower limits, the lifting motor does not stop after the movement collides, and the anti-collision switch is abnormal.

3.5.1 Check whether the connector is securely connected

and the terminal is detached, unplug the 8 anti-collision switch, and measure whether the wiring harness is on or off normally with the buzzer of multimeter. If it is abnormal, replace the corresponding harness assembly.

3.5.2 Measure the red and black lines of the anti-collision switch with the buzzer of multimeter, press and release the anti-collision switch, and check whether the switch is on and off normally. If it is abnormal, replace the anti-collision switch harness assembly.

Otherwise, replace the movement board.

3.6 If the lower movement remains at the lower limit position, and the signal and circuit of the lower movement are normal, check whether the anti-collision switch of the upper movement is open or the connector falls off. On the other hand, if the upper movement has been in the upper limit position, and the signal and circuit are normal, it is also necessary to check whether the anti-collision switch of the lower movement is open or the connector falls off.

#### **4. The massage machine is kneading abnormally.**

4.1 The massage machine has no kneading action.

4.1.1 Turn on the manual control of the tablet and let the massage machine give kneading instructions. Measure whether the terminal of the connector at the kneading motor of the movement board 17 has a voltage output of about DC9-20V with a multimeter DC voltage range. If there is no voltage output, the movement board is broken and can be

replaced.

4. 1. 2 If there is voltage output, check whether the docking connector from 17 to the kneading motor harness is secure and whether the terminals are in good contact. If it is normal, unplug the connector and use the multimeter buzzer to measure the on-off situation of the red and black wires at the connector 17 of the core board to the two ends of the black two-core 450B connector. If they are all connected, it means that the kneading motor is broken and the core needs to be replaced. If it doesn't work, you need to replace the kneading motor harness assembly; The method for judging whether the kneading motor is damaged is the same as that in 3.1.3 for judging the lifting motor.

4. 2 As soon as the massage chair is turned on, the kneading function will run. If it can't be turned off by tablet operation, the movement board is broken and can be replaced.

## **5. Abnormal tapping of massage machine.**

5. 1 The massage machine has no tapping action.

5. 1. 1 Turn on the manual control of the tablet and let the massage machine tap. Use the DC voltage range of the multimeter to measure whether the voltage at both ends of the connector at the tapping motor of the movement board 16 has a voltage output of about DC9-20V. If there is no voltage, the movement board is broken and normal after

replacement.

5.1.2 If the voltage of the movement board is normal, check whether the plug connector from the movement board to the tapping motor is firm and whether the terminals are in good contact. If it is normal, unplug the connector, and measure the connection and disconnection of the red and black wires from the connector 16 of the movement board to the white two-core connector 450B with a multimeter buzzer. If they are all connected, it means that the tapping motor is broken and the movement needs to be replaced. If the two wires are not connected, the tapping motor harness assembly needs to be replaced. The method of judging whether the tapping motor is damaged is the same as that of 3.1.3 for judging the lifting motor.

5.2 As soon as the massage chair is turned on, the tapping function will run. If it can't be turned off through tablet operation, the movement board is broken and needs to be replaced.

5.3 Open the flat plate to make it work in the tapping state. If the width, middle and narrow can't be selected or wrong, the signal of the movement is faulty. Use a multimeter to measure whether there is 5V/DC output from the red and black wires of the connector at the wide, medium and narrow signal position of the movement board 3, and if there is no output, the movement will

The board is broken and normal after replacement. If there is voltage output, check whether the connector from the movement board 3 to the movement width signal on the right is firmly inserted and whether the terminal is out. If they are all normal, measure 3 places with the buzzer of multimeter. Red, brown, yellow, black to the right width of the signal terminal on and off. If it doesn't work, replace the

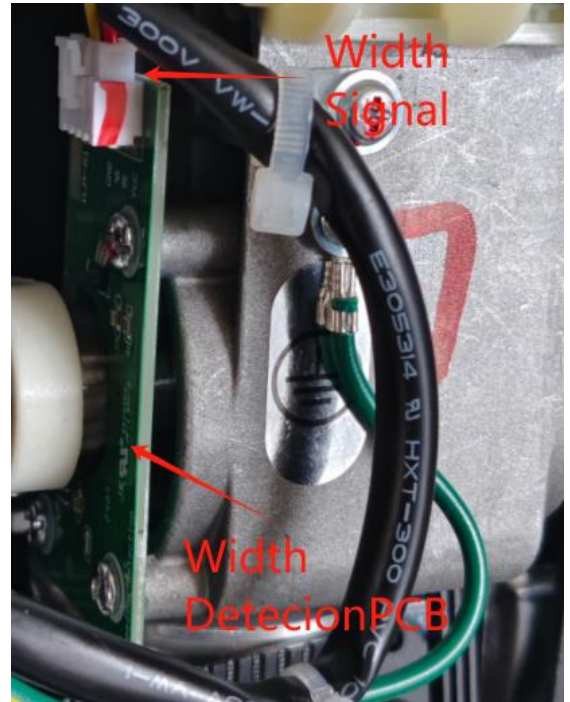

wide, medium and narrow detection signal harness assembly. If they are all connected, use a magnet to approach and leave the Hall element, and measure whether there is voltage change between brown, black, yellow and black lines. If there is no explanation that the wide, medium and narrow detection board is damaged, it will be normal after replacement. Otherwise, replace the movement board. If the width is selected, keep kneading. Measure whether there is DC5V voltage on the red and black lines at the kneading counting position of the movement board 9 with a multimeter DC voltage range; if not, replace the movement board; Measure whether there is high-low level change between the yellow and black lines, and replace the movement board if there is. same

Methods Test whether the voltage between the red, yellow and black lines of the kneading counting board is normal. If there is no voltage, replace the kneading counting harness. If the voltage is normal, replace the kneading counting plate. As shown on the right.

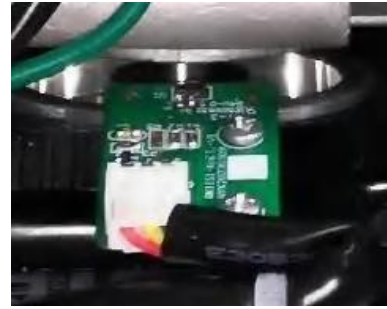

## 6. The massage machine leans forward abnormally.

6.1 The massage machine leans forward without action. Turn on the manual control of the tablet, let the massage machine forward, put the multimeter in the DC voltage range, and measure whether the voltage output at both ends of the connector at the forward motor of the movement board 14 is normal. If there is no voltage, the movement board is broken and normal after replacement. If the voltage is normal, check whether the connector between the movement board and the wire harness of the forward tilting motor is firm and whether the terminals are in good contact. Then use multimeter buzzer to measure the red and black wires at the movement board 14 to the wire harness of the forward tilting motor.

If all the black three-core 450B connectors are connected, it means that the forward tilting motor is damaged and needs to be replaced. If it doesn't work, you need to replace the wire harness assembly of the forward tilting motor; The method

for judging whether the tilting motor is damaged is the same as that in 3.1.3 for judging the lifting motor.

6.2 The massage machine leans forward not in place or exceeds the limit. Explain the forward count fault. This situation can be divided into two types. One is that the forward-leaning counter plate is faulty and normal after replacement (see 6.3). One is that the position of "magnetic steel induction plastic parts" in Figure 4 has changed. The solutions are as follows:

1. As shown in Figure 6, ensure that the gear is fully meshed with the second tooth of the rack. If it is not fully engaged, adjust the rotating shaft of the forward tilting motor until it is engaged. Align the plastic magnet with the lower Hall element and fix it.

6.3 Lean forward to top or bottom. Put the multimeter in the DC voltage range, use the magnet to approach and leave the Hall element, and measure whether the voltage output between the brown, orange and black wires at the forward limit of the movement board 4 is normal. If there is voltage, the movement board is broken and normal after replacement. If there is no voltage, check whether



the wiring harness between the movement board and the forward tilting limit board is normal; if it is normal, replace the forward tilting motor limit board; Otherwise, replace the forward tilt signal harness assembly.

## **7. The whole machine is not inflated or one way is not inflated.**

7.1 If the whole machine is not inflated, use the multimeter AC voltage range after starting, and measure whether the two connectors at 7 places on the main board have AC voltage of about AC24V. If the connectors have fallen off, check whether the wiring harness is on or off. If it is normal, the air pump is broken, and replace the air pump. If there is no voltage output and the voltage at 22 places is normal, the motherboard is broken and can be replaced.

7.2 Check whether the trachea has fallen off, blocked, broken, poorly inserted, damaged and leaked;

7.3 If a certain road is not inflated.

7.3.1 Use a multimeter DC voltage range to measure whether there is a DC24V voltage output at the corresponding port. If there is no output, the corresponding motherboard or armrest board is broken and can be replaced.

7.3.2 Or shut down, use the multimeter buzzer to measure whether the wiring harness between the solenoid valves is abnormal, and replace it if it is abnormal. Use a multimeter to measure the resistance of the corresponding solenoid valve.

(The resistance of solenoid valve is 165 10%). If there is no resistance or the resistance is too large, the solenoid valve is broken and can be replaced.

7.3.3 Check whether the trachea between the solenoid valve and the airbag is broken or falls off;

7.4 If the inflation is weak. Check whether the trachea, solenoid valve and airbag are blocked, leaked or damaged.

7.5 For the left and right handrails and leg and foot electromagnetic valves not working, in addition to checking DC24V, it is also necessary to check whether the wiring harness between the serial ports of the left armrest, 15 leg and foot of the motherboard 13 and 34 right armrest respectively reaches the communication serial port of the left and right handrails 8 and the serial ports of the two leg and foot plates is normal, whether the connectors are firmly connected and whether the terminals are detached; Replace the corresponding harness if it is abnormal. Check whether there is any abnormality in the wiring harness of the solenoid valve, and replace it if it is abnormal.

The corresponding ports of solenoid valves are as follows:

:Whole machine part

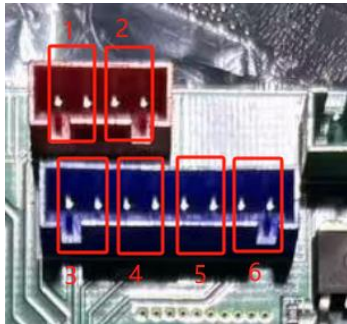

Right armrest part:

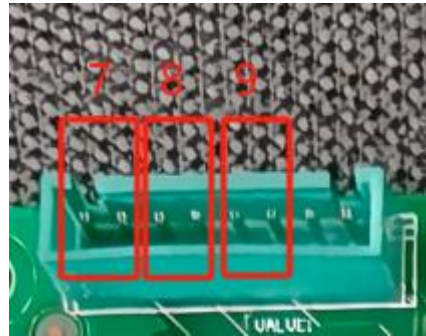

Left armrest part:

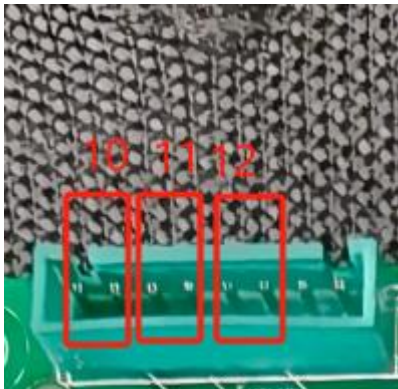

Leg and foot parts:

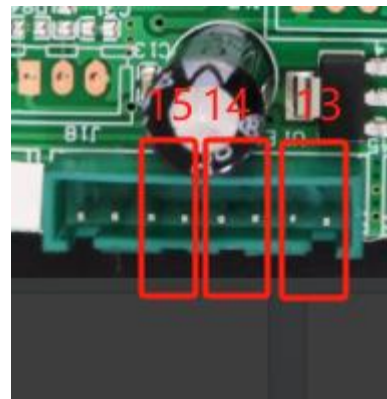

1	Right Shoulder	9	Hand Front
2	Right Waist	10	Hand Front
3	Right Seat	11	Hand Middle
4	Left Shoulder	12	Hand Back
5	Left Waist	13	Foot Side
6	Left Seat	14	Leg Side
7	Hand Back	15	Heel
8	Hand Middle	16	

## 8. Abnormal action of back brace

8.1 The electric strut does not move.

8.1.1 Put the multimeter in DC voltage range, insert two probes into the blue connector terminal at the 20-back brace, and operate the backrest lifting button of the flat hand controller to observe whether the multimeter has

DC24V output. If there is no voltage, the motherboard is broken and normal after replacement.

8.1.2 Check whether the wiring harness from 20 places to the brace butt connector is plugged in, whether the terminal is out, check whether the wiring harness is on or off, and replace the corresponding wiring harness assembly if it is disconnected. Unplug the brace butt connector, and check the resistance between the two wires of the brace. If the brace is at the upper and lower limit, it is good to conduct it in one direction by diode, positive and negative tests. In other positions, it is normal to conduct it in 3-20Ω. Other conditions prove that the electric brace motor is broken, so replace the electric brace.

8.2 The electric stay cannot stop at the initial massage position.

8.2.1 Put the multimeter in the DC voltage range, insert two probes between the green and gray wires of the connector at the counting signal of 33 poles, and operate the lifting button of the backrest of the flat hand controller to observe whether the multimeter has high and low level output. If there is high and low level, the motherboard is broken and normal after replacement.

8.2.2 Check whether the wiring harness between the struts is on and off and whether the connectors are connected securely. If it is normal, the struts are broken, and it is normal after replacement. Otherwise, replace the

corresponding harness assembly.

## 9. Abnormal movement of leg brace

9.1 The electric strut does not move.

9.1.1 Put the multimeter in DC voltage range, insert two probes into the terminal of the green connector at the 19-leg strut, and operate the backrest lifting button or leg lifting button of the tablet hand controller to observe whether the multimeter has DC24V output. If there is no voltage, the motherboard is broken and normal after replacement.

9.1.2 Check whether the wiring harness from point 19 to the brace butt connector is plugged and whether there are any terminals. Check whether the wiring harness is on or off, and replace the corresponding wiring harness assembly if it is disconnected. Unplug the brace butt connector, and check the resistance between the two wires of the brace. If the brace is at the upper and lower limit, it is good to conduct it in one direction by measuring with diode, positive and negative tests, and in other positions, it is 3-20Ω. Other conditions prove that the electric brace motor is broken, so replace the electric brace.

9.2 The electric stay cannot stop at the initial massage position.

9.2.1 Put the multimeter in the DC voltage range, insert two probes between the yellow and black wires of the connector at the counting signal of 33 poles, and operate the lifting button of the backrest of the flat

hand controller to observe whether the multimeter has high and low level output. If there is high and low level, the motherboard is broken and normal after replacement.

9. 2. 2 Check whether the wiring harness between the struts is on and off and whether the connectors are connected securely. If it is normal, the struts are broken, and it is normal after replacement. Otherwise, replace the corresponding harness assembly.

Electric strut interchange inspection: When the faulty circuit board is not obviously burned, the power supply and signal of the leg and back struts are interchanged at the same time, that is, the faulty strut is replaced with the normal strut circuit, and the strut function is normal; if the strut is normal, the circuit board is broken. Otherwise, if the electric strut fails, it can be replaced.

## **10. The sole roller does not work**

10. 1 Turn on the function of the sole roller (air pressure at the legs and feet) and it won't work. Use the multimeter DC voltage range to measure whether there are DC24V and DC5V in the 1DC24V input and 2 leg board serial connectors in Figure 3. If it is abnormal, check whether the connectors between motherboards are plugged, the wiring harness is on and off, and the connection is normal. If it is abnormal,

replace the plugged wiring harness.

10. 2 Put the multimeter in the DC voltage range, and insert two probes into the terminals of the roller motor connector at 9 places in Figure 3. Is the output voltage normal? If there is no voltage, the legs and legs are broken. If there is voltage output, use a multimeter to measure whether the voltage at both ends of the red and black wires of the 450 connector at the other end of the harness is 24V. If there is no voltage, replace the harness assembly, otherwise the roller motor is broken and replace it.

#### **11. Leg rubbing motor does not work.**

11. 1 Turn on the leg roller function (air pressure at the legs and feet) and it won't work. First press 10.1 to check whether there is any problem with the wiring harness between motherboards.

11. 2 Put the multimeter in the DC voltage range, and insert two probes into the terminals of the 8-point leg rubbing motor connector in Figure 3. Is the output voltage normal? If there is no voltage, the leg plate is broken; If there is voltage output, use a multimeter to measure whether the voltage at both ends of the brown and blue wires of the 450 connector at the other end of the harness is 24V. If there is no voltage, replace the harness assembly, otherwise the leg rubbing motor is broken, and replace it.

#### **12. Telescopic motor works abnormally.**

First press 10.1 to check whether there is any problem with the wiring harness between motherboards.

12. 1 Telescopic motor does not work.

12. 1. 1 Check whether the motor and limit harness connector are plugged securely, whether the plug connector is plugged securely and whether the terminal is detached;

12. 1. 2 Put the multimeter in DC voltage range, insert two probes into the terminals of the telescopic motor connector at 10 places in Figure 3, operate the telescopic button on the leg of the flat hand controller, and observe whether the multimeter has DC24V output. If not, it is normal after replacement. Unplug the telescopic harness plugged into the motor, and measure whether there is DC24V output. If there is no DC24V output, the telescopic harness will be damaged and replaced.

12. 1. 3 Check the resistance between the two wires of the telescopic motor (normally 5-30 ohms). If there is no resistance or it is too large, it indicates that the motor is faulty, so replace it.

12. 1. 4 Measure the voltage between the green, yellow, white and black wires of the telescopic counting signal harness of the leg and foot plate J9 with the multimeter in DC range, and respectively block the photoelectric switch of the counting plate to see if there is any level change. If there is any voltage change, replace the leg and foot plate. Check the connection harness for continuity. If it doesn't

work, it can be replaced. Otherwise, replace the counting plate.

12. 2 Boot legs and feet are extended.

12. 2. 1 Check whether the sole detection sensor is damaged. Measure the length of 4 legs in Figure 3 with a multimeter in DC range to check whether there is DC5V on feet 1 and 3. If there is no replacement of the leg and leg plates.

12. 2. 2 Measure the left and right leg lengths with the buzzer of multimeter to detect whether the red, blue and black wire harnesses are on or off. If it doesn't work, replace this wire harness. Measure the voltage between the blue and black wires of the orange connector with a multimeter in DC range. Press and release the sole of the foot to check whether there is any high-low level change. If there is any voltage change, the leg plate is broken and it can be replaced. Otherwise, replace the sole detection sensor.

12. 3 Legs and feet do not protrude, after inspection according to 12.1. Use a multimeter to measure whether there is any voltage change between J23 blue and black lines when the leg and foot board 3 touch the ground. If not, replace the touchdown detection assembly; Otherwise, replace the leg plate.

12. 4 Legs and feet do not retract, after inspection according to 12.1.

12. 4. 1 Check whether the anti-pinch detection board is

damaged. If the indicator light is always on, replace the anti-pinch detection board.

12. 4. 2 Measure the red, blue and black wire harness of the anti-pinch hand harness with the buzzer of multimeter. If it fails, replace this wire harness. Measure the length of 4 legs with a multimeter in DC range to detect whether there is voltage change between the blue and black wires of J24 and J25. If not, replace the anti-pinch detection plate assembly; Otherwise, replace the leg plate.

### **13. Leg heating cloth does not work**

13. 1 Turn on the leg heating function in the flat panel. First press 10.1 to check whether there is any problem with the wiring harness between motherboards. Check whether the connectors between the heating cloths are firmly connected and whether the terminals are out.

13. 2 Measure whether the voltage at 11 heating place in Figure 3 is DC24V; If there is no voltage output, the leg and foot plates are damaged; If there is voltage output, use a multimeter to measure whether the plug-in of the heating wire pair has DC24V; if not, please replace the heating wire; If there is voltage, please replace the heating cloth.

### **14. Foot heating cloth does not work.**

14. 1 Turn on the foot heating function in the tablet. First press 10.1 to check whether there is any problem with the wiring harness between motherboards. . Check whether the connectors between

the heating cloths are firmly connected and whether the terminals are out.

14. 2 Measure whether the voltage at heating point 13 in Figure 3 is DC24V; If there is no voltage output, the leg and foot plates are damaged; If there is voltage output, use a multimeter to measure whether the plug-in of the heating wire pair has DC24V; if not, please replace the heating wire; If there is voltage, please replace the heating cloth.

### **15. Shawl heating cloth does not work**

15. 1 Check whether the connectors at 32 places are plugged securely and the terminals are detached, and whether the DC plug of the shawl heating harness is plugged securely; Whether the heating line inside the shawl is reliable.

15. 2 Turn on the shawl heating function in the flat panel, put the multimeter in DC voltage range, insert two probes into the blue connector terminal of 32 shawl heating place, and measure whether there is DC24V. If there is no voltage, the motherboard is damaged and can be replaced; Measure whether the DC head of the back heating wire has DC24V output. If there is no voltage, check whether the connection and disconnection of the heating wire harness and the connector between the DC head and the motherboard are normal. If it is not good, replace it. If there is voltage, the heating cloth is damaged and can be replaced.

### **16. Abnormal physiological detection function**

16. 1 Boot control is normal. Open the tablet health monitoring, and it can't be detected. Check whether the contact surface of the physiological detection module is seriously dirty or covered, and if it is, clean it.
16. 2 Check whether the wiring harness and connectors between the right armrest circuit board 10 and the left armrest physiological detection module are firmly connected, whether the terminals are out, and whether the wiring harness is on and off normally. If it falls off, it can be inserted. If the on-off is abnormal, replace the corresponding harness assembly.
16. 3 Measure the white and gray lines of the physiological serial port of the right armrest board 10 with a multimeter DC voltage range. Whether there is voltage output (DC5V) between the terminals, and the voltage between the red and black wires of the physiological module docking connector can also be measured. If there is no voltage output, replace the motherboard. Otherwise, replace the physiological detection module.
16. 4 Physiological test LED is not on. Measure whether there is DC5V between the pin 1 and the pin 2 of the physiological detection LED connector of the right armrest plate 5, and replace the armrest plate if there is no DC5V; Otherwise, replace the physiological detection lamp assembly.

## 17. The horn doesn't ring and the voice is abnormal.

17.1 The horn doesn't ring. The mobile phone is connected to Bluetooth and plays music. Measure the voltage at the motherboard connector 21, whether it is DC12V; If there is no voltage output, the motherboard is damaged;

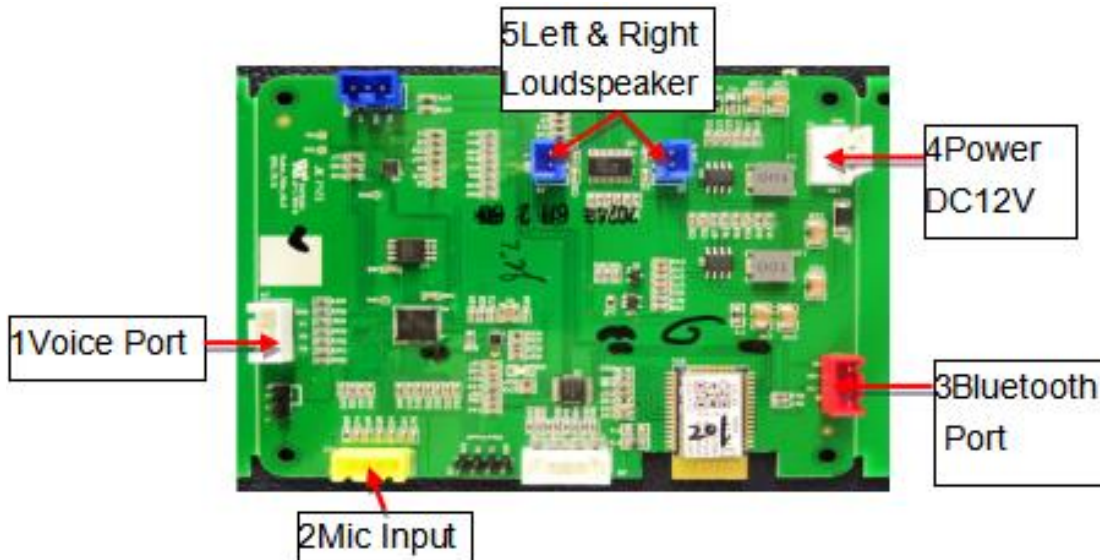

17.2 Check whether the power supply J1 of the voice board 4 has DC12V voltage; if not, check whether the plug-in connector is connected and the wiring harness is on and off normally; if not, replace the corresponding wiring harness; If there is voltage output, use multimeter AC to measure whether the left and right speakers J2 and J3 of the power amplifier board 5 have jumping voltage output; if not, replace the voice board; If there is voltage, replace the horn after checking that there is no problem with the wiring harness of the left and right horns.

17.3 Abnormal voice. Press 17.1 and 17.2 to check that there is no problem. Check whether the connector between the voice board and the microphone assembly is plugged in, whether the terminal is out, and whether the wiring harness is on and off

normally. If it is normal, replace the microphone assembly.

Otherwise, replace the wire harness.

17. 4 The voice can't be recognized. After step 1, 2 and 3, the fault remains, replace the voice board.

17. 5 Voice is not controlled. Measure whether there is DC5V at both ends of the voice serial port in Figure 1 with a multimeter DC voltage range. If it is not checked whether the wiring harness between the voice serial ports of the right armrest plate 9 and the connector connection are normal, replace the corresponding wiring harness if it is abnormal. Check that both ends of the connector of the right armrest plate 9 have ; No DC5V output, if the armrest plate is not replaced. Otherwise, replace the voice board.

#### **18. Negative ions don't work.**

18. 1 Turn on the negative ion function. Measure the voltage at the negative ion J18 and J19 connectors of the motherboard 24, whether it is DC12V; If there is no voltage output, the motherboard is damaged;

18. 2 Check whether there is voltage between the mainboard and the shoulder pair plug-in; if not, replace the corresponding wiring harness; If there is voltage output, replace the negative ion related component assembly.

#### **19. Aromatherapy doesn't work.**

19. 1 Turn on the tablet and turn on five aromatherapy modes in turn. Measure the voltage at the connector of the aromatherapy fan on the motherboard 23, whether it is DC12V; If there is no voltage output, the motherboard is damaged and can

be replaced;

19.2 Check whether there is voltage between the mainboard and the shoulder pair plug-in; if not, replace the corresponding wiring harness; If there is voltage output, replace the corresponding faulty aromatherapy fan.

19.3 Check whether the trachea between the fan and the aromatherapy port falls off, leaks, etc., and whether the outlet is blocked.

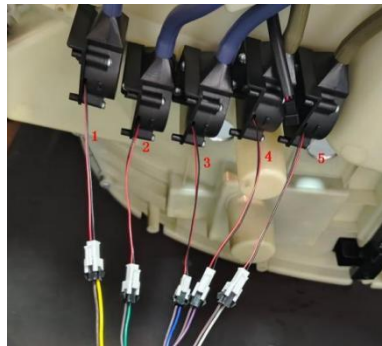

## 20. Abnormal charging.

20.1 Abnormal wireless charging.

20.1.1 Use a multimeter to measure the DC voltage range, and check whether there is a DC24V voltage output between the red and black lines of the wireless charging output (DC24V) of the left armrest circuit board 3. If there is no voltage, replace the armrest board.

20.1.2 Check whether the connector between the armrest board and the wireless charging board is firmly connected, and the terminal Whether there is any protrusion.

20.1.3 Measure whether there is DC24V voltage at both ends of the input connector of the wireless charging module. If not, replace the

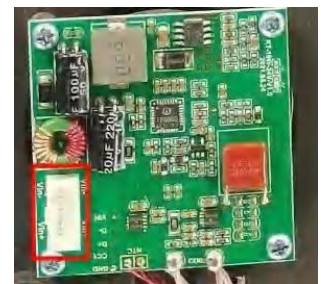

wiring harness assembly between the conversion board and the charging board or replace the wireless charging module. As shown on the right

20. 2 USB charging is abnormal.

20. 2. 1 Use a multimeter to measure the DC voltage range, and check whether there is a DC24V voltage output between the red and black lines of the wireless charging output (DC24V) of the right armrest circuit board 3. If there is no voltage, replace the armrest board.

20. 2. 2 Check whether the connector between the harness of USB charging board and the right armrest board is firmly connected and whether the terminal is out. If not, replace the corresponding harness assembly.

20. 2. 3 Plug in the phone to charge. Use the multimeter DC voltage range to measure whether there is DC24V at the white 3.96 connector on the fast charging module. If there is, measure whether there is voltage output (about DC5V, fast charging is above DC8V) between the red and black wires of the output connector of the charging module. If the charging module is not replaced. It is measured that the USB wire harness is on and off. If it is not, replace the wire harness, or



replace the USB circuit board.

20. 3 The tablet is charging abnormally.

20. 3. 1 Use the multimeter DC voltage range to measure whether there is DC5V voltage at both ends of the charging pin in the right armrest flat bracket, as shown in the figure on the right. If not, unplug the support rod, and measure whether the charging needle is on or off at the other end with a multimeter buzzer. If not, replace the flat support rod assembly.



20. 3. 2 Measure the charging connection of the right armrest plate 7 with a multimeter DC voltage range.

Whether there is DC5V voltage at both ends of the connector, if there is, replace the flat charging harness assembly 1 (harness between the circuit board and the flat supporting rod).

20. 3. 3 Using the multimeter DC voltage range, measure whether there is DC5V voltage at both ends of the DC5V connector from the main board of the right armrest board 16. If there is, replace the right armrest board.

20. 3. 4 Check whether the plug-in connector between the right armrest 16 and the DC5V power supply of the right armrest of the motherboard 14 is firmly connected, whether the terminal is out, and whether the wiring harness is on or off abnormally. If it is abnormal, replace the corresponding harness assembly.

20. 3. 5 Using the multimeter DC voltage range, measure

whether there is DC5V voltage at both ends of the DC5V power connector on the right armrest of the motherboard 14, and replace the motherboard if there is no DC voltage. Otherwise, replace the flat plate.

20. 3. 6 If the flat plate is placed on the flat plate bracket for charging, the whole machine will be abnormal or stop, and the flat plate will be replaced if the charging needle is normal.

## 21. Abnormal shoulder height detection

21. 1 Shoulder height detection, after the lifting motor reaches the top of the backrest, it stops as soon as it goes down. This phenomenon is that the current of the lifting motor is large or fluctuates greatly. Connect the DC current of the multimeter in series to the control circuit of the lifting motor (or connect the red or black electronic wire with the pliers), and measure whether the current of the no-load lifting motor is between DC 0.3 and 0.45a. If it is too large (above DC0.6A), replace the lifting motor, or replace the movement board.

21. 2 The shoulder height detection movement stops near the waist. This phenomenon is that the current of the lifting motor is small, according to

21. 1 Measure the current, if the current is low when pressing the shoulder, replace the lifting motor, otherwise replace the movement board;

## 22. Abnormal heating of movement.

22. 1 Check whether the connector falls off. Measure the resistance of 10 upper left wheel signal and 11 upper right wheel

signal sensors with a multimeter. The normal resistance is about 5K (25°C), if there is no resistance.

(or very large) or very small, replace the corresponding temperature sensor.

22. 2 If the sensor is normal, start the machine and turn on the heating. If there is no DC24V output from the heating output of the machine core board, the sensor of the machine core board will detect the circuit fault and replace the machine core board.

22. 3 Turn on the heater, and use multimeter to measure whether the connectors of 12 right upper wheel heater and 13 left upper wheel heater have DC24V voltage output. If there is no voltage output, replace the movement board.

22. 4 Measure the resistance of heating elements for 12 upper right wheel heating and 13 upper left wheel heating with multimeter resistance, and replace the corresponding heating elements if the circuit is open;

### 23. LED strip works abnormally.

23.1 Leg and foot LED is abnormal. Start the machine, and measure it with a multimeter in DC range. In Figure 3, whether there is DC12V output at both ends of the 12DC12V light strip, if there is no output, the legs and legs are broken, so it can be replaced. Otherwise, replace the foot lamp belt assembly.

23.2 Handrail LED is abnormal

23. 2. 1 Measure whether the wiring harness between the communication lines of the left and right handrails of the motherboard and the left and right handrails is normal and whether the connectors are firmly connected with each other by using the buzzer of the multimeter. If it is abnormal, replace the corresponding harness assembly.

23. 2. 2 Turn it on. Use a multimeter to measure whether there is DC12V voltage at both ends of the 12LED strip connector of the left and right armrest circuit boards 12. If there is no voltage, replace the armrest circuit board.

23. 2. 3 Use the multimeter DC voltage range to measure whether there is DC12V at both ends of the docking connector. If there is voltage, LED strip assembly.

23. 3 LED strip anomaly of shoulder.

23. 3. 1 Power on, select additional functions, and turn on 5 phototherapy modes. Measure the voltage (pin 1 and pin 2, pin 3 and pin 4) at the LED connector on the shoulder of the main board 27, whether it is DC12V; If there is no voltage output, the motherboard is damaged, and more



Just change it; As shown on the right.

23. 3. 2 Check whether the connector between the motherboard and the shoulder LED strip is firmly inserted, and whether the terminal has come out. If it is abnormal, replace

the corresponding wiring harness;

23. 3. 3 Check whether there is voltage between the motherboard and the plug-in of the shoulder LED strip; if not, replace the corresponding wiring harness; If there is voltage output, replace the LED strip corresponding to the fault.

#### **24. Armrest closing signal is abnormal.**

24. 1 After the armrest is closed, a red light is displayed, the chair works abnormally, and the function cannot be opened.

24. 1. 1 After the door is closed, use the multimeter to measure whether the voltage between the red and black lines of the door lock switch signal of armrest plate 15 is low. If it is low, replace the armrest plate.

24. 1. 2 Unplug the connector and use the multimeter buzzer to measure whether there is continuity between the red and black wires. If there is no continuity, check whether the limit switch is pressed by the door lock structure. If it is pressed, replace the armrest door lock switch assembly. Otherwise, adjust the door lock structure to ensure that the door is closed and the switch is pressed.

24. 2 The switch door LED is abnormal. When opening and closing the door, use the multimeter DC gear to measure the armrest plate.

Whether there is DC5V voltage output at both ends of 6-door closed LED and 14-door opened LED connectors, if not, replace the armrest board, otherwise replace the armrest lock lamp assembly.

## 25. Abnormal tablet control.

25. 1 Flat panel does not display. The tablet is charged for a long time. Press the power-on button to see if it is turned on. If you can't press the reset button to restart the power-on, if it is abnormal, replace the tablet.

25. 2 The tablet cannot be controlled.

25. 2. 1 Open the tablet and enter the setting interface to see if the Bluetooth switch is turned on. Whether to connect with Bluetooth massage chair. If not, just open it and reconnect it.

25. 2. 2 If Bluetooth cannot be connected, press 17.1 to check whether the voice board is normal. Using multimeter bee

Check whether the wiring harness between the Bluetooth serial port of voice board 3 and the right armrest board is abnormal, whether the connector is firmly connected, and whether the terminal is out.

Replace the Bluetooth communication cable if it is abnormal.

25. 2. 3 Measure whether the wiring harness between the communication port of the main board of the right armrest board 8 and the serial port of the right armrest of the main board 34 is normal, whether the connector is plugged in normally, and whether the terminal is out. Replace the corresponding harness if it is abnormal.

25. 2. 4 Measure whether there is DC5V voltage at both ends of the communication port of the main board of the right armrest board 8 with a multimeter DC voltage range, and replace the right armrest board if there is; Measure whether there is DC5V voltage at both ends of the serial port of the right armrest of the motherboard 34. If there is no replacement of the motherboard.

25.3 The tablet can't control the massage process. It can't be controlled by pressing the simple hand controller. Check whether the door closing light of the left and right armrest is red, which means the armrest is opened during the massage. Close the left and right armrest after shutdown and reset. Turn on and make sure that the left and right armrest lock light is white, which means the door is closed normally. If it is abnormal, check it according to 24. Armrest closing signal is abnormal.

### III . Mechanical failures and solutions:

#### 1. Replace the massage mech assy.

1.1As shown in the figure, remove 6 pieces of ST4.2\*16 screws with a cruciform screwdriver and remove the back cover.



1.2 As shown in Photo 2, remove 6 pcs 4\*10 screws by a Phillips screwdriver.

1.3 Pull out the upper and lower movement. Dis-assemble the upper movement assembly.

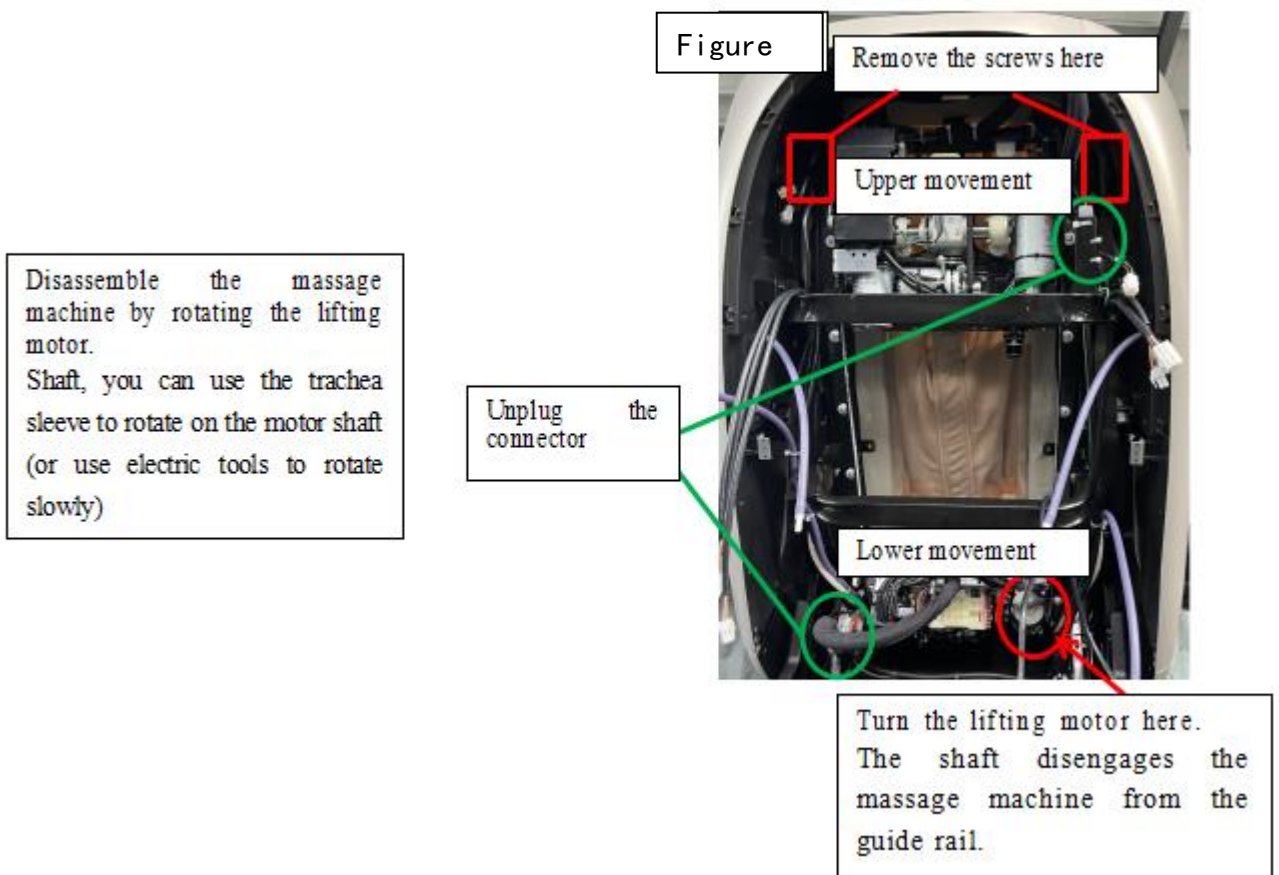

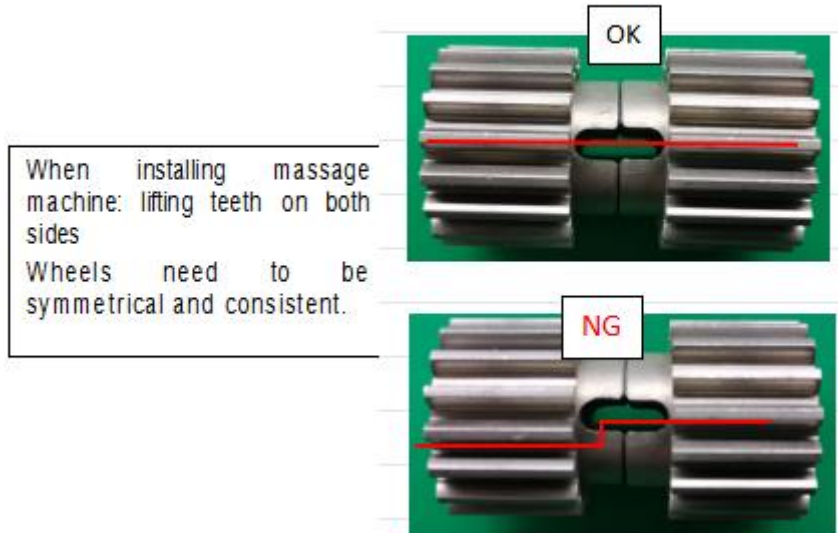

## 2. Dismantle the armrest assembly and shoulder.

### 2.1 Dismantle armrest assembly

2.1.1 As shown in the figure below, turn off the whole machine, then open the armrest to the maximum state, then remove the M6\*30 socket head cap screw, then unplug the armrest, the connecting piece of the whole machine and the trachea, lift it up forcibly, separate the armrest from the whole machine, and remove the armrest assembly.

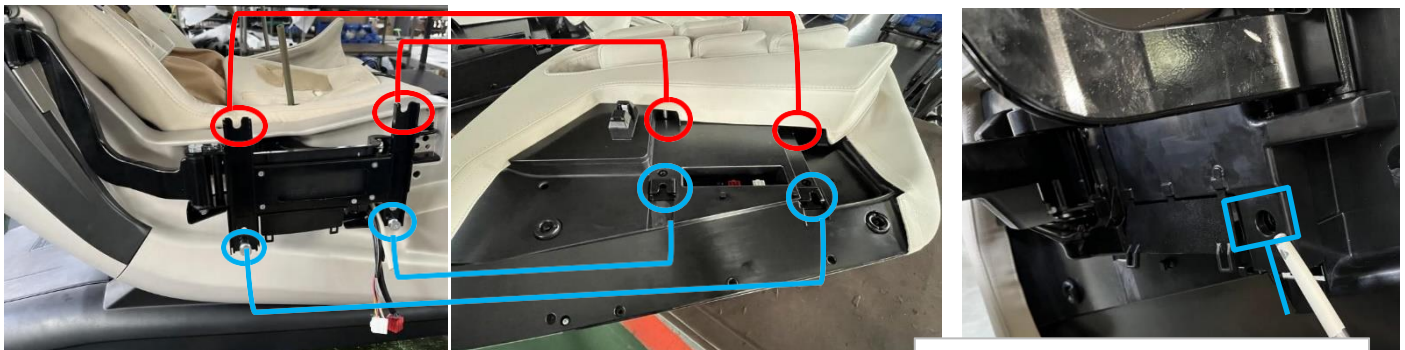

M6\*30 hexagon socket head

## 2. 1. 2 Dismantle handrail assembly

### 2. 1. 2. 1 As shown in the figure, use tools

Remove the 7 screws on the armrest plastic body (at this time, the armrest is in snap connection) and then forcibly separate the inner and outer housings (be careful not to pull the wire harness, remove the connector plug of the housing harness and take off the housing).



## 2. 1. 3 Dismantle upper armrest assembly

2. 1. 3. 1 Disassemble the upper armrest assembly, first tear off the anti-skid pad, and then use

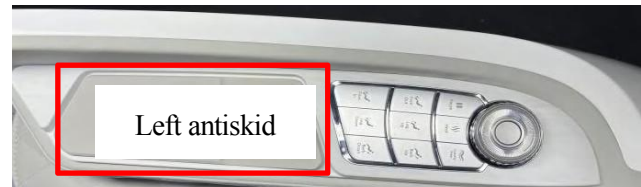

use



Remove the screw with the tool, forcibly separate the buckle, unplug the connector, then remove the upper handrail assembly and replace the internal parts.



2. 1. 3. 2 As shown in the figure, according to the problem point, disassemble and replace the internal parts of the handrail.

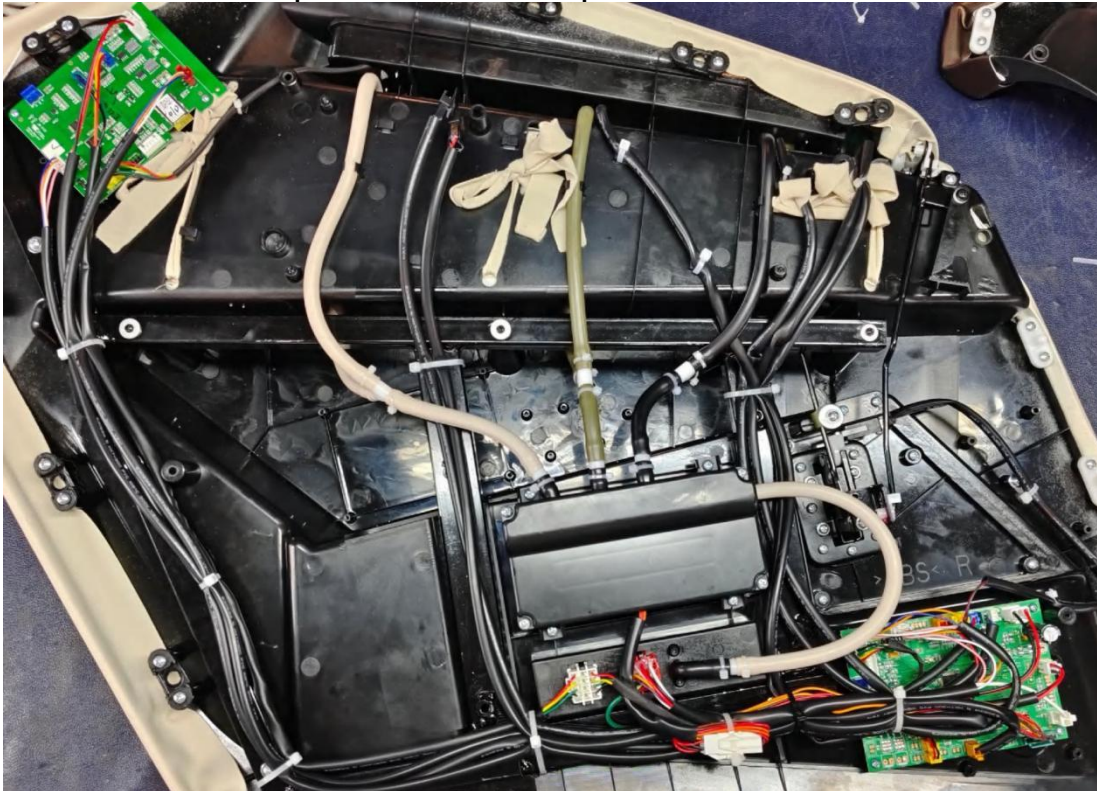

2. 1. 3. 2. 1 After the handrail is locked, the white light will normally be on. If the red light is on but the handrail is still locked, it is necessary to adjust the inside of the handrail and lock the limit switch of the handrail (the paddle is slightly moved outward, otherwise it is moved inward).

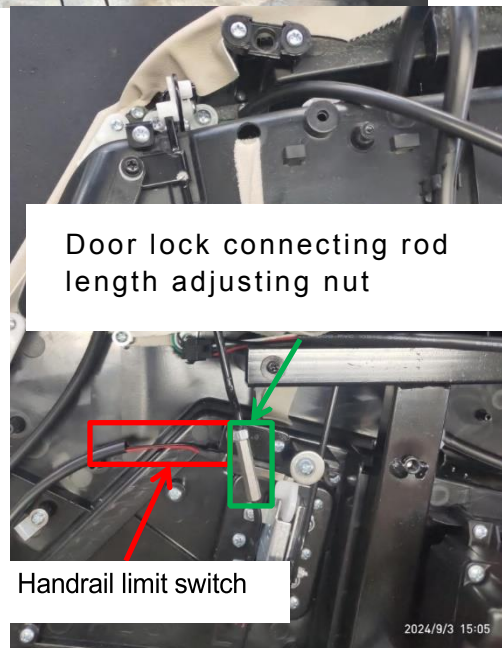

2. 1. 3. 2. 2 Armrest lock is not tight (open the door after gently pulling the handrail): at this time, it is necessary to shorten the length of the door lock connecting rod

(screw the length adjusting nut of the door lock connecting rod to shorten the connecting rod).

2. 1. 3. 2. 3 When the armrest closes the door, it will be directly bounced off: at this time, it is necessary to lengthen the length of the door lock connecting rod (screw the adjusting nut of the door lock connecting rod length to lengthen the connecting rod).

2. 1. 4 Disassemble the armrest housing part assembly and lamp strip.

2. 1. 4. 1 Remove the fixing screws of the inner and outer shells according to the previous procedure, take out the handrail outer shell, remove the screws fixing the upper and lower shell assemblies of the handrail with electric tools, and then replace the upper and lower shells of the handrail and the handrail light strip according to the situation.

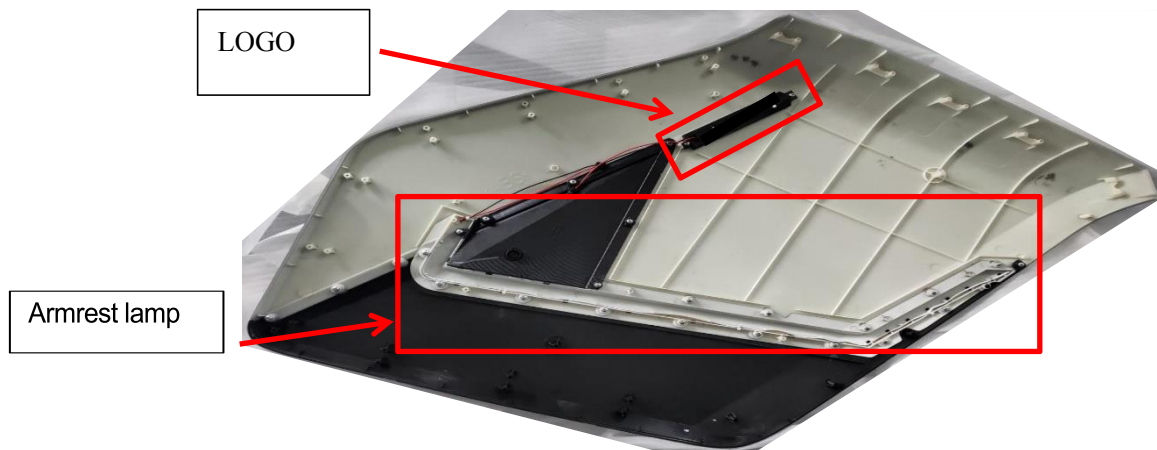

2. 1. 5 Disassemble the physiological detection assembly

Remove the screw with a tool, unplug the connector, and then remove the physiological testing assembly for replacement.

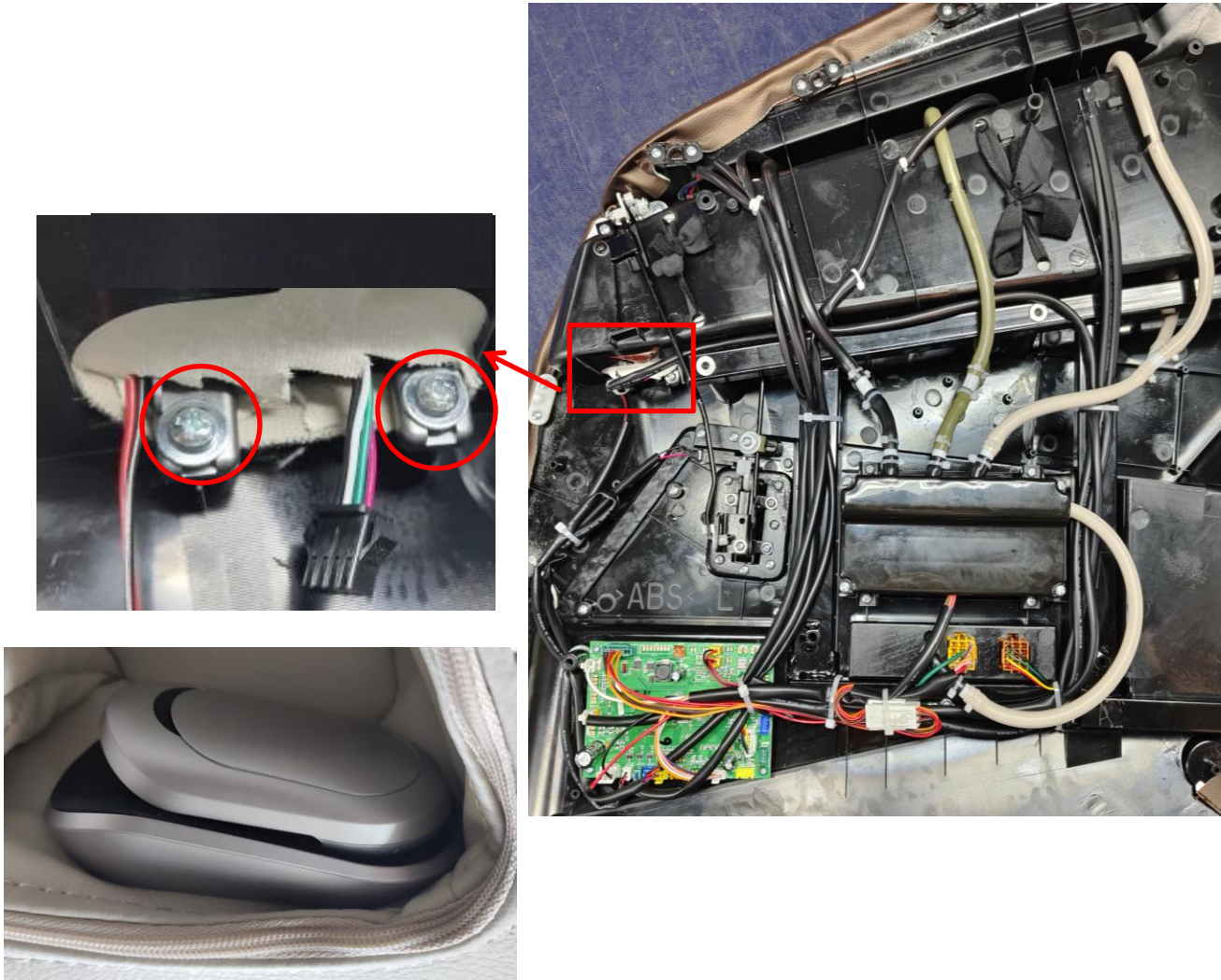

## 2. 1. 6 Replace armrest solenoid valve assembly.

2.1.6.1 Remove the 4 screws fixing the solenoid valve assembly, and then remove the connecting wire harness and air pipe.

2.1.6.2. Remove four screws on the solenoid valve cover to expose the solenoid valve, remove four screws for fixing the solenoid valve and replace the solenoid valve.

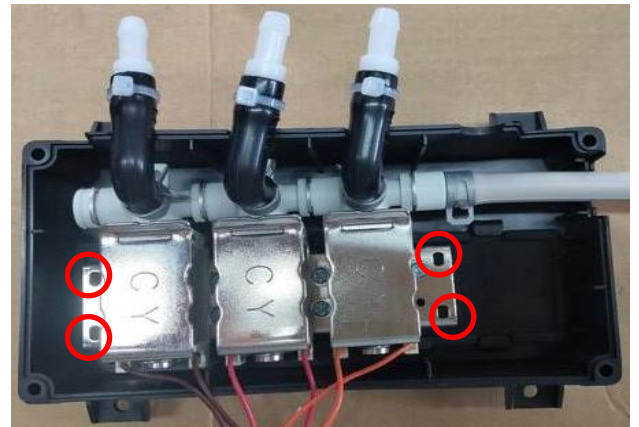
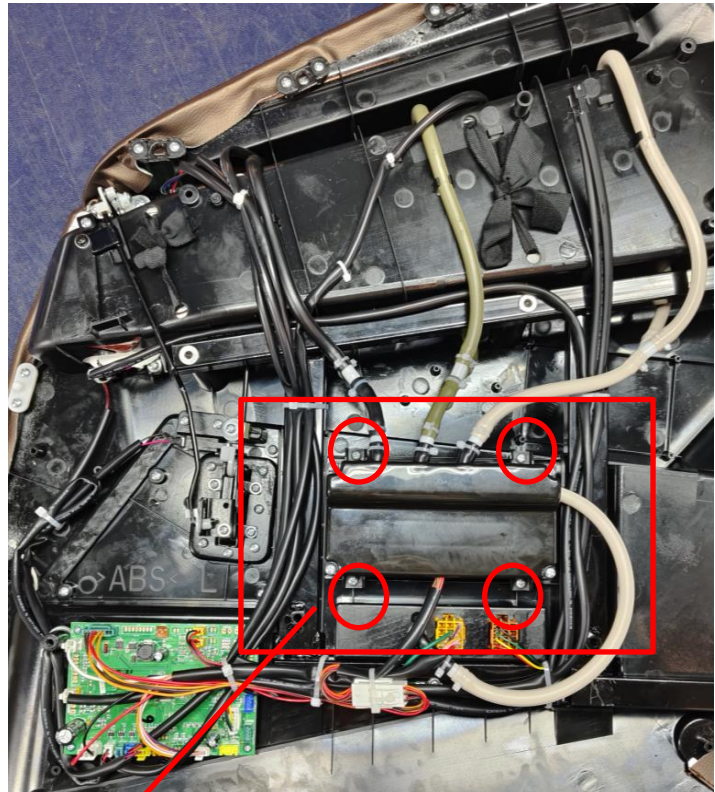

2. 2 Remove the shoulder assembly

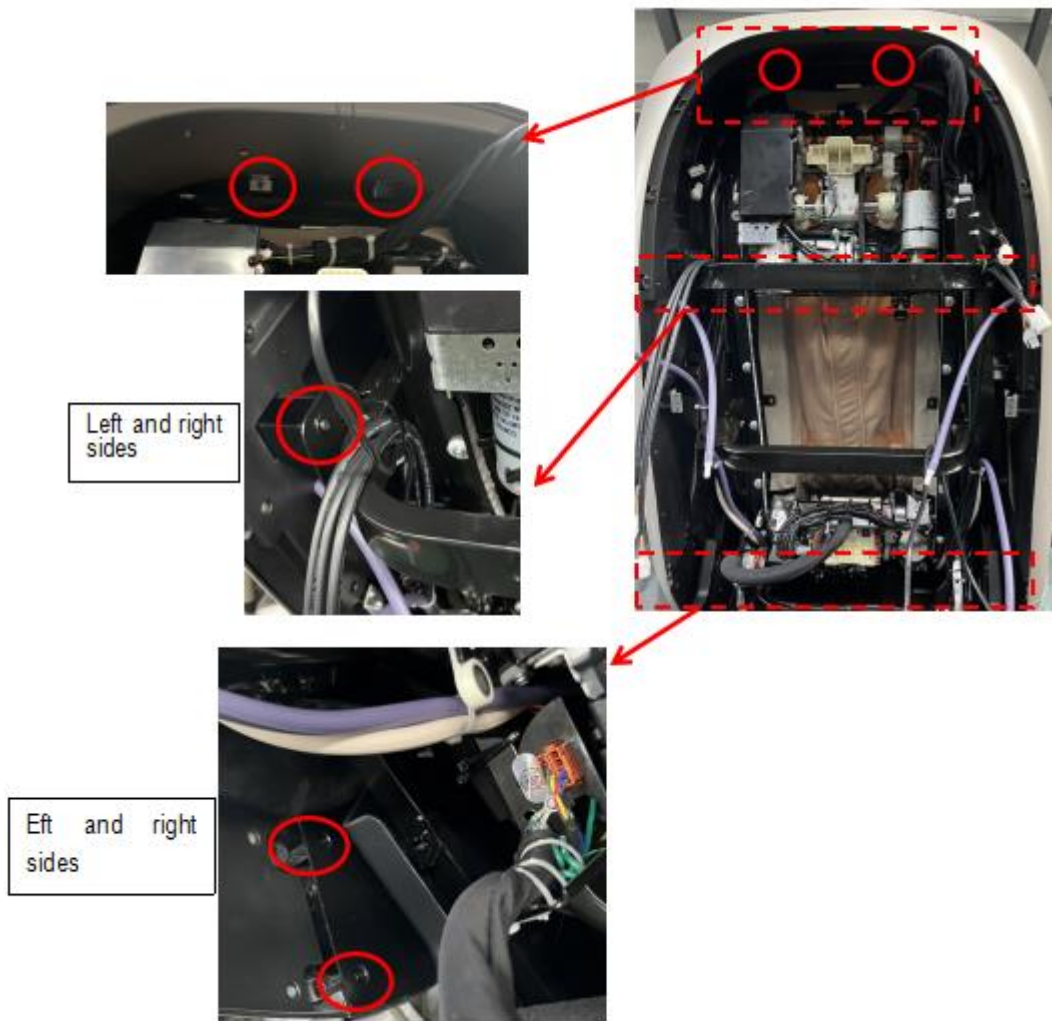

As shown in the above figure, first remove the backrest cover, then remove 10 screws above the shoulder assembly, on both sides of the shoulder, at the joint of the shoulder decoration, and at the front end of the backrest (below the airbag), and then connect them.



Unplug the air pipe and plug connector, and replace the shoulder assembly.

### 2. 2. 1 Shoulder disassembly assembly

When assembling the inner and outer shoulder assemblies: under the shoulder airbag's fixed points, 1 under the negative ion/aromatherapy cover  
Fixed point, two fixed points under the horn cover.  
(39 fixed points in total)

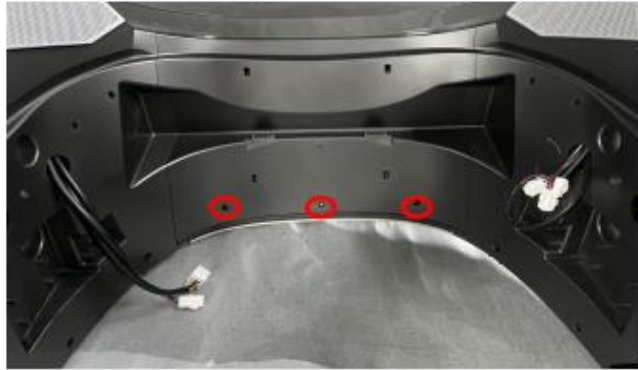

As shown in the above figure: use tools to remove 39 screws, separate the shoulder inner and outer shells, then remove the shoulder outer shell and replace the internal parts and components assembly.

### 2. 2. 2 Replace the shoulder rear light strip assembly.

2. 2. 2. 1 As shown in Figure 1, firstly remove 6 screws with tools, then unplug the harness connector and remove the shoulder light strip assembly.

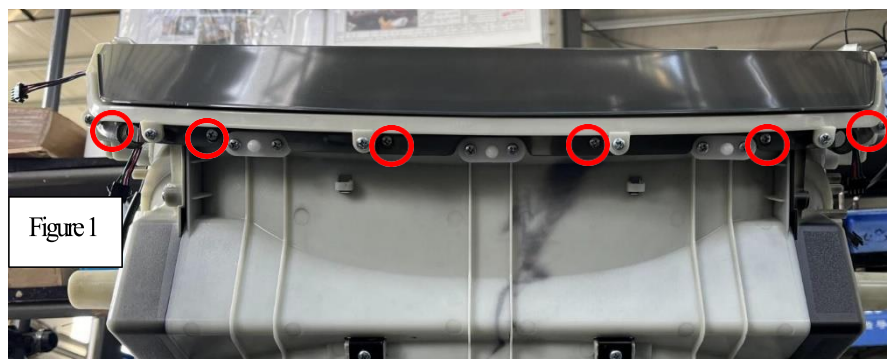

Figure 1

2. 2. 2. 2 As shown in Figure 2/3, remove 6 screws on the light strip assembly with tools, take out the light strip assembly and replace the light strip.



### 2. 2. 3 Removing shoulder airbag

As shown in the figure, first unzip the sewn product, then remove the screw under the shoulder airbag bag, take the shoulder airbag out of the airbag bag to expose the PP board, and then unplug the air pipe connecting the airbag to replace the shoulder airbag. (Note: When replacing, grab the trachea to prevent it from being found in the PP board)



#### 2. 2. 4 Replace the left and right lamp strip assemblies behind the shoulder.

As shown in the figure: use tools to remove the screws, remove the light bar fixing assembly, and then replace the light bar.



#### 2. 2. 5 Remove the negative ions on the shoulder and the fan.

As shown in the figure, remove the screw for fixing the negative ion assembly, unplug the wire harness to replace the negative ion

assembly, remove the screw for fixing the fan, unplug the wire harness and connect the air pipe to replace the fan;

Left shoulder detachment Sub/fan

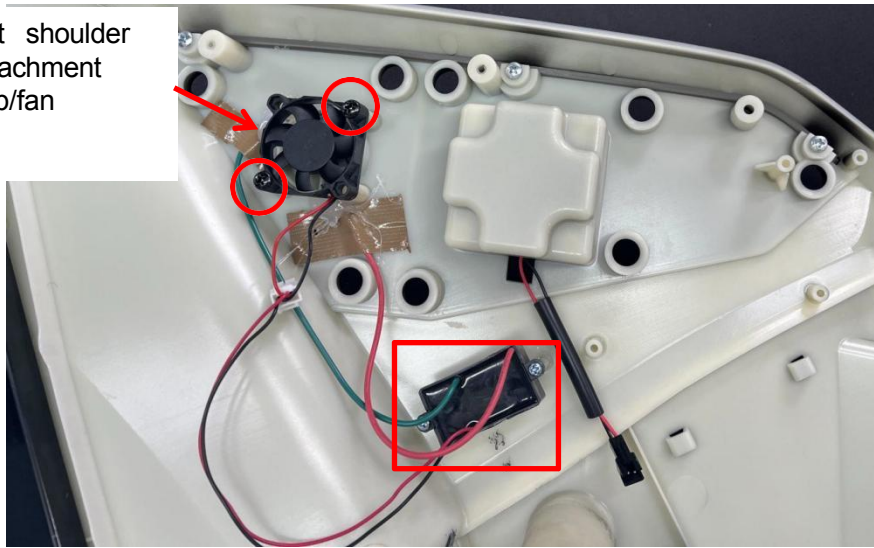

The air tube should be here, otherwise it is easy to get squeezed.

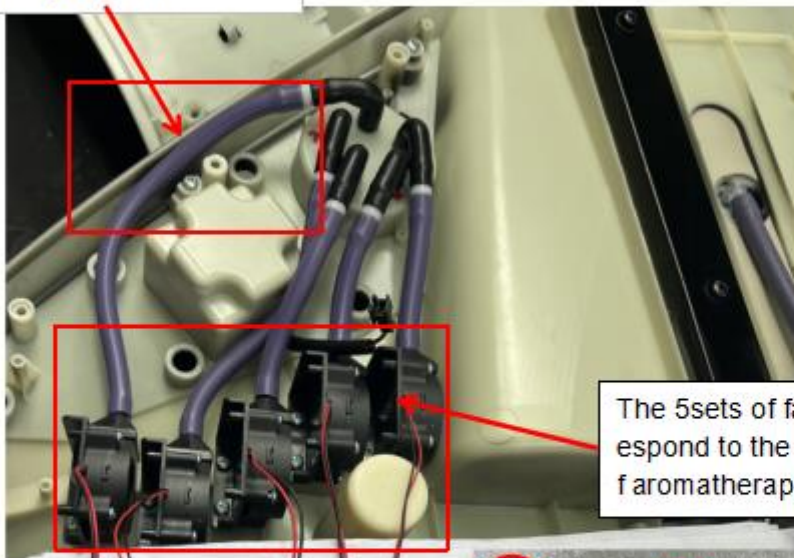

The 5sets of fans correspond to the 5sets of aromatherapy.



### 3. Disassemble the plastic body assembly of the front backrest

As shown in the figure, after the rear guard is removed, remove the screws at the left and right sides and the front at the position shown in the figure.

End 2 screws, then pull out the front seat side of the backrest and the waist airbag trachea, and replace the plastic body assembly of the front backrest.

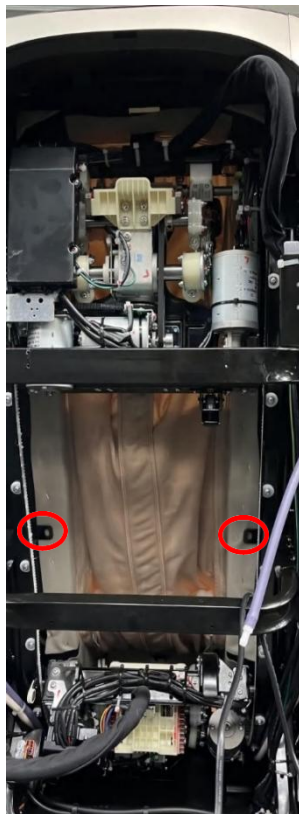

## 4. Dismantle the power box assembly

4.1 As shown in the figure:

4.1.1 Remove 3 screws on the power box cover with tools, and shake it left and right to remove the power box cover.



4.1.2 According to the maintenance situation, disassemble the screws of all parts and replace the parts that need to be replaced. The red ring screw is shown here.

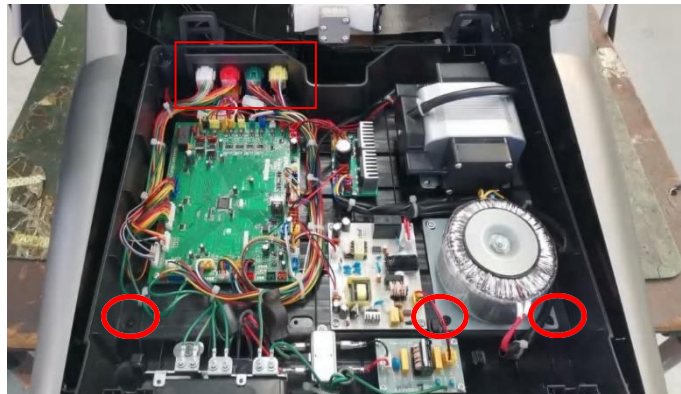

After removal, the power box assembly can be replaced after unplugging the plug connector and air pump air pipe.

## 5. Dismantle the legs and feet

As shown in the figure on the right, first lift the leg and foot assembly, unplug the connector and air tube, then use tools to remove the 2



screws connecting  
the leg and foot, and  
replace the leg and  
foot assembly.

### 5.1 Dismantle foot assembly

5.1.1 As shown in the following figure, use tools to remove the screws in the position shown in the figure, then remove the rear guard of the legs and feet, replace the guard components and repair the internal structure.



### 5.2 Replace the foot assembly and solenoid valve.

5.2.1 As shown in the following figure, first remove the screw as shown in the figure with a screwdriver, then unplug the wire harness and the air pipe in turn, and replace the foot assembly and the solenoid valve assembly.



### 5.3 Replace the leg and foot telescopic strut.

5.3.1 As shown in the figure, use tools to remove the two M6\*12 screws in the figure, then remove the pine leaf pin +B8\*40 pin shaft, then unplug the connector connecting the wiring harness, and replace the leg and foot telescopic strut assembly.

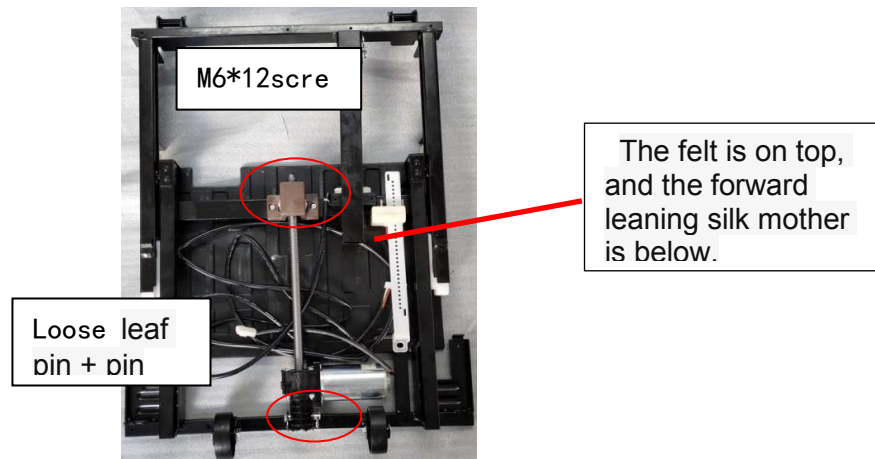

### 5.4 Dismantle the leg frame.

5.4.1 As shown in the figure below, the sewn products are pulled apart first. Then remove the airbag from the zipper, take the airbag out of the sewing cloth sleeve, then remove the position screw in the figure, and replace the leg frame and leg massage assembly.

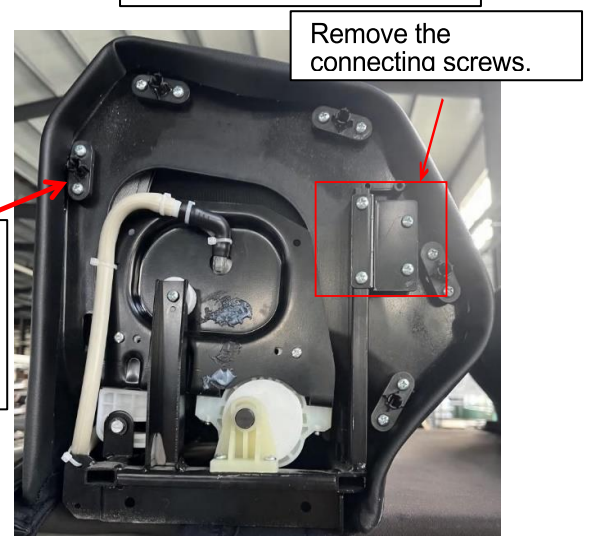
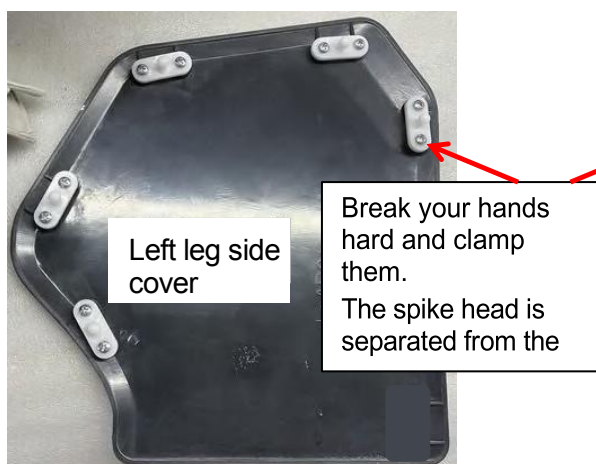
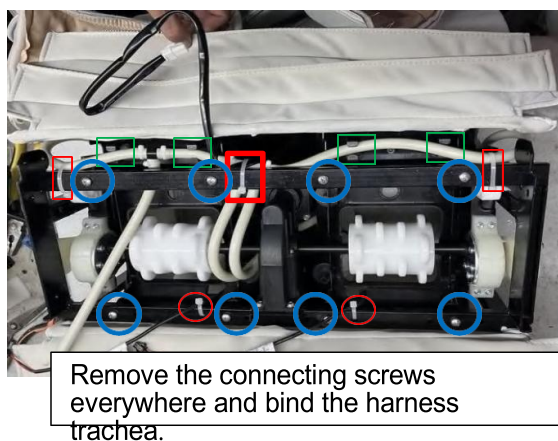

5.4.2 Remove the leg massage assembly, and screw the position as shown in the figure and Remove the connector and replace the leg massage assembly.

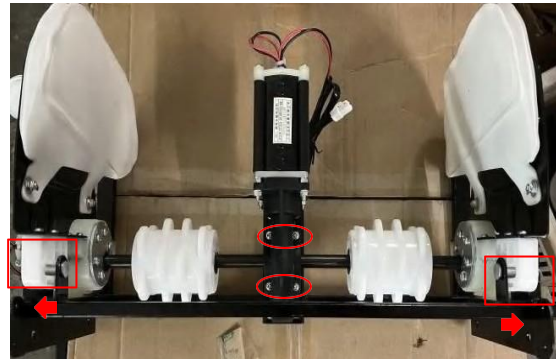

5.5 Remove the foot roller as shown in the figure, use tools to remove the screws in the figure, unplug the wiring harness connector, then remove the foot massage

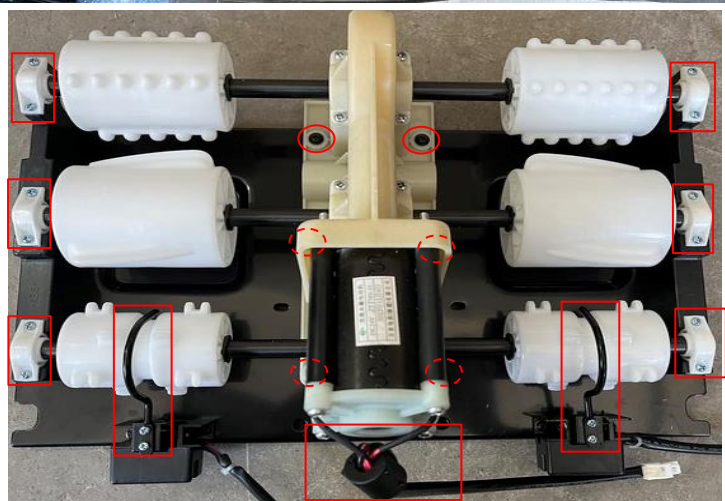
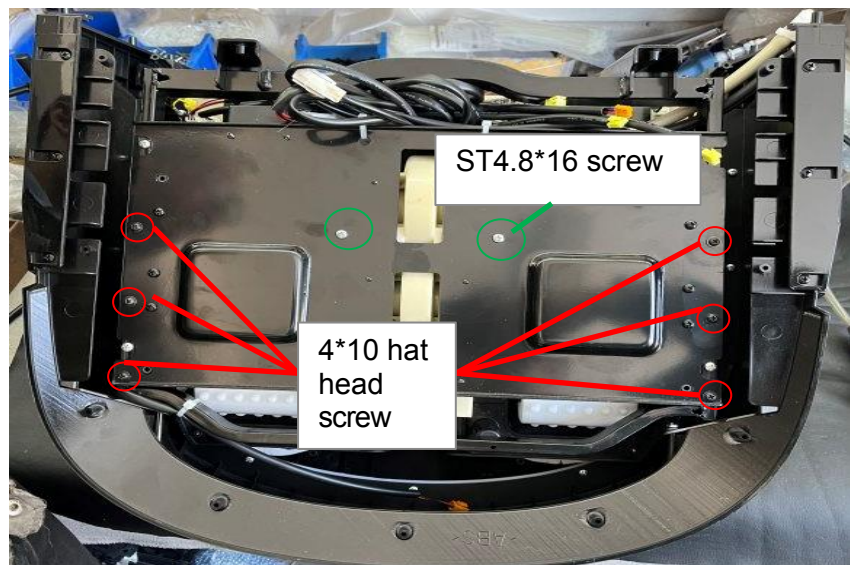

assembly and  
replace it.

### 5.6 Replace the foot anti-pinch and solenoid valve assembly.

According to the position shown in the figure, remove the foot upper and lower shells, and then remove the foot anti-pinch detection plate for replacement.

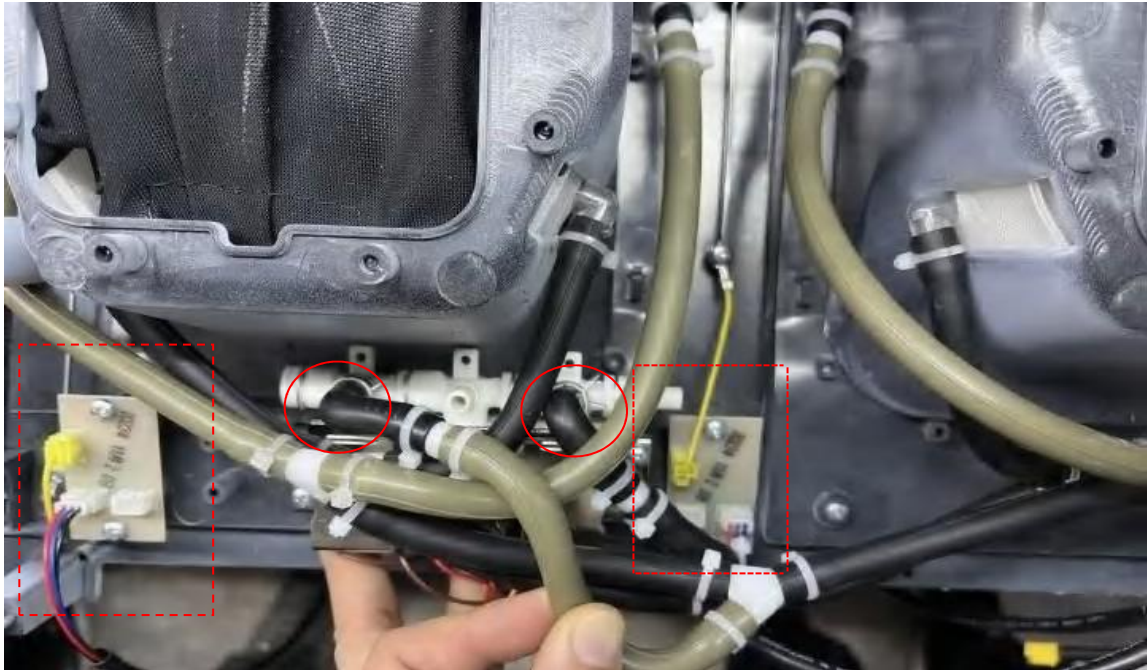

### 5.7 Replace the foot light strip assembly.

As shown in the figure, remove the screws at all parts as shown in the figure and replace the foot light strip assembly.

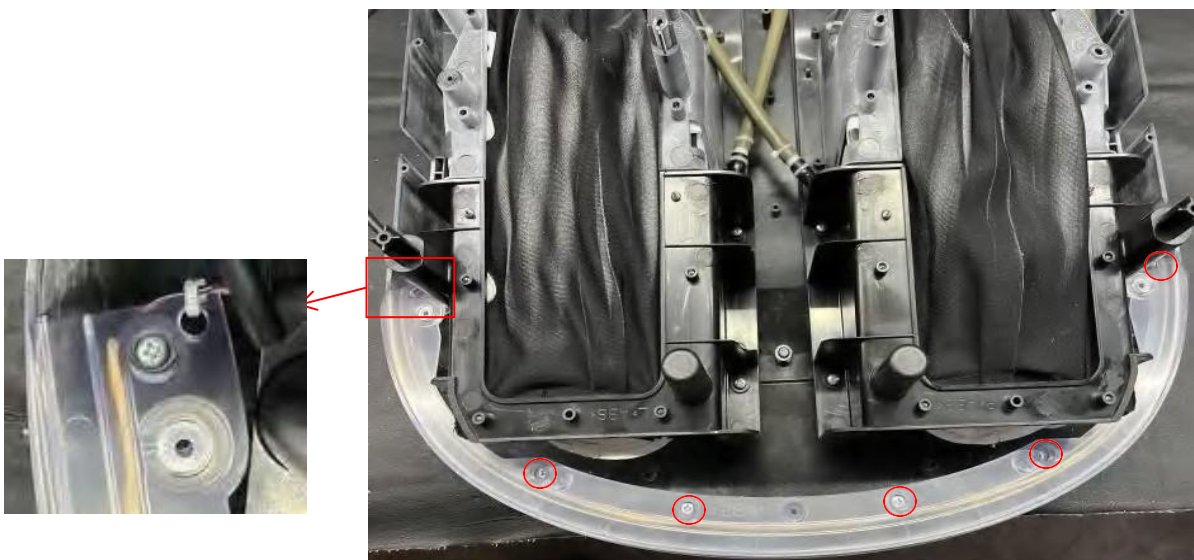

## 6. Remove the backrest strut and leg strut assembly.

### 6.1 Remove backrest strut assembly.

Simple way: after removing the leg and foot assembly (remove the leg and foot assembly according to the above procedure 5), then turn the massage chair sideways, and remove the anti-loose leaf pin from the exposed place at the bottom of the massage chair, and then remove the pin shaft and one end of the strut; At the other end, use M6 Allen wrench to remove the screws around the fixing strut, take out the flat push rod fixing plate assembly, remove the connecting harness, and replace the backrest assembly strut.

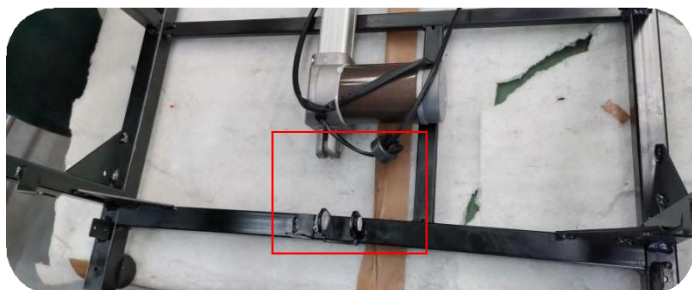
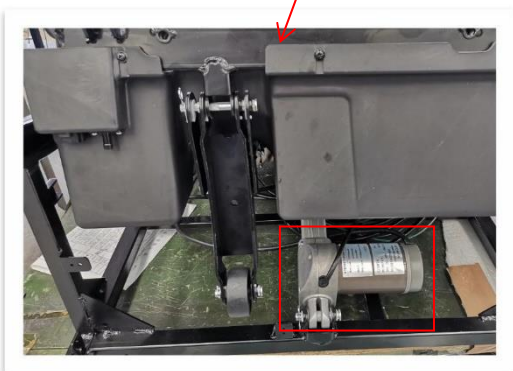
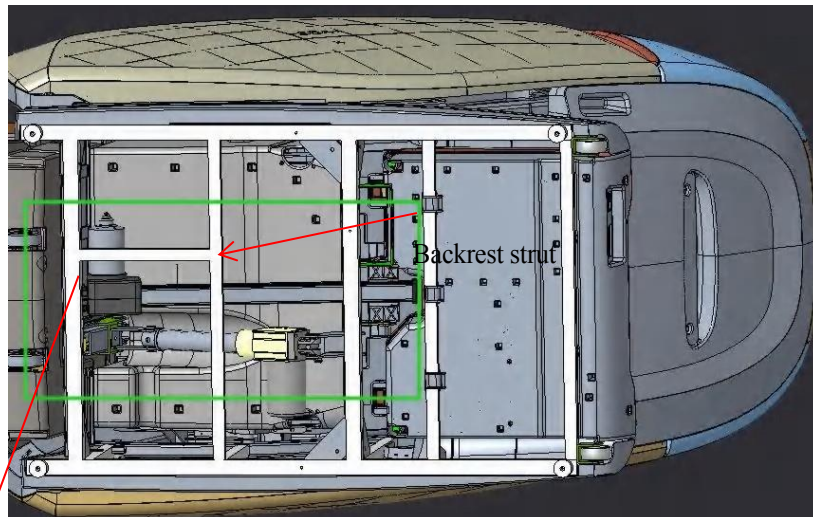

## 6.2 Remove the leg brace assembly.

From that bare place at the bottom of the massage chair, firstly, remove the anti-loose leaf pin from one end of the stay bar with the motor, then remove the pin shaft and one end of the stay bar; Then put the massage chair straight, remove the pine leaf pin and pin shaft from the front, remove the connecting harness and replace the

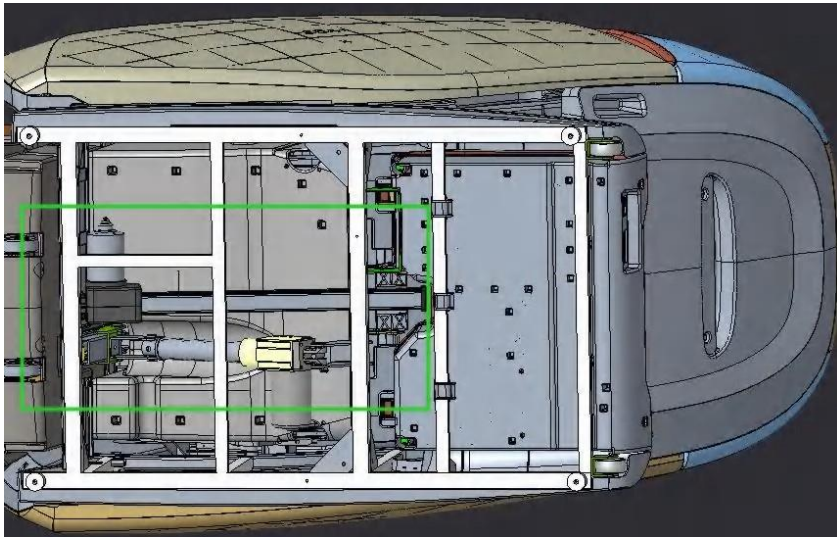

## 7. Disassemble the electromagnetic valve assembly of backrest frame.

7.1 Remove the armrest assy according to the 2.1 process.

7.2 Remove the left and right lower guard plate assemblies.

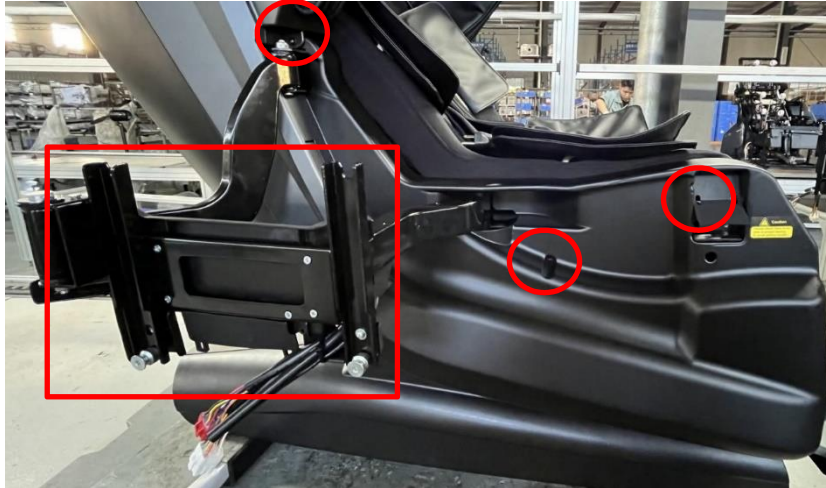

7.2.1 As shown in the figure on the right, first move the connecting rod assembly to the last position (the maximum position for opening the door), then use tools to remove three screws on the lower guard plate assembly, and then rotate the lower guard plate to move the position to expose the solenoid valve on the backrest frame assembly, so as to replace the solenoid valve assembly.



7.2.2 Unplug the wiring harness and air pipe connecting the solenoid valve, and use tools to remove the screws at 4 places to fix the solenoid valve and replace the solenoid valve.



## 8. Adjust the gap between handrail assembly and shoulder.

8.1 First, remove the handrail assembly according to step 2.1.1.

8.1.1 Turn the link frame assembly to the inside closest to the massage chair, remove the screw that fixes the lock catch adjusting plate, and then use a wrench to forcibly turn the pin shaft on the lock catch adjusting plate to make the gap between the armrest assembly and the shoulder reach the best state.

8.1 make the gap between the armrest assembly and the shoulder reach the best state.

The connecting rod frame assembly is rotated to be closest to the inner side of the massage chair.



When adjusting the gap, remove the screws here, then fix them firmly after the adjustment.



Or use a flat screwdriver to rotate the slot position above the pin shaft.

Adjust the gap between the handrail and the shoulder by turning the pin counterclockwise/clockwise with a wrench.

## 9. Repair the massage machine assembly

9.1 As shown in the following figure 1, remove the screws fixing the lower frame connecting plate with tools, and then remove the lower frame assembly.

9.2 As shown in Figure 2, remove the screws fixing the upper frame connecting plate with tools, unplug the connectors at all parts, separate the wire harnesses at all parts, and then separate the massage mechanism from the whole frame.

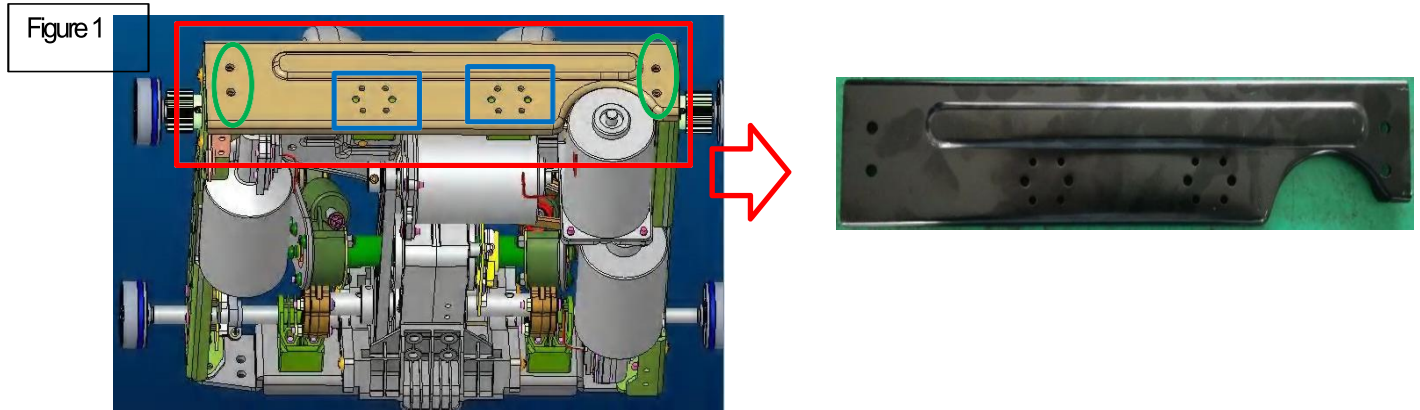

9.3 Replace the lifting and tilting motor assembly.

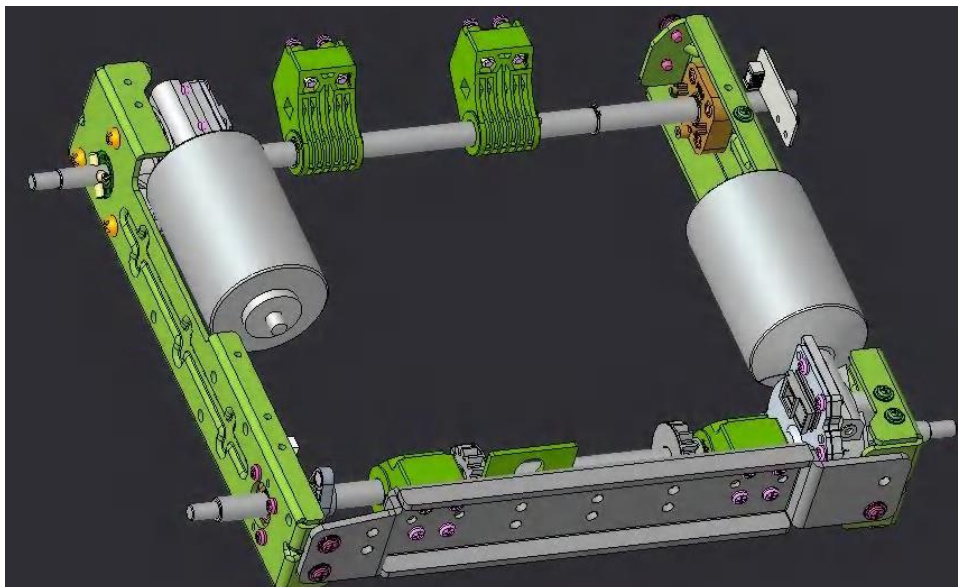

9.3.1 As shown in the above figure: firstly, plug the electrical test fixture into the lifting and tilting motors to test the motor sound. If the motor rotates with abnormal sound, replace the motor shaft

assembly.

9.3.2 Remove the fixing screws of all parts according to the position shown in the above figure, and remove the lifting shaft assembly and the tilting shaft assembly for replacement.

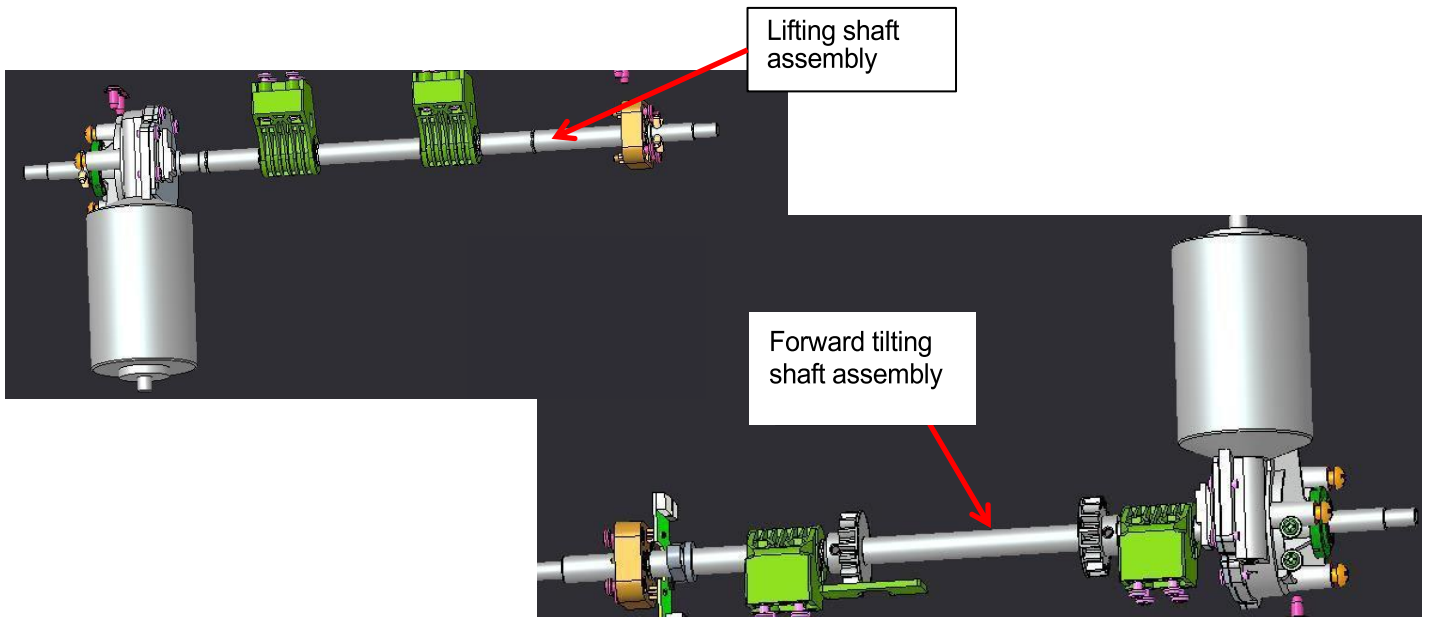

9.4 Replace the kneading and tapping motor assembly.

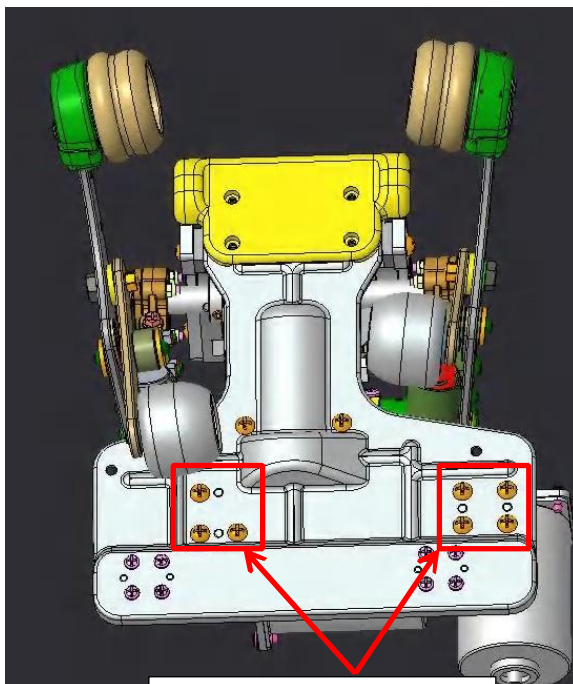

Remove the screws here and replace the motor assy.

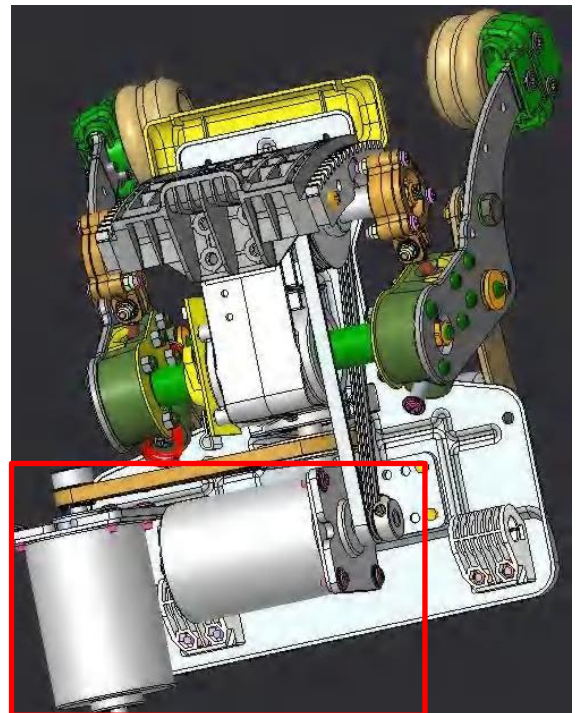

9.4.1As shown in the figure, firstly, remove the pulley from the motor, test the fixture with electrical appliances, and electrify it to test whether the motor rotates with abnormal sound. If it rotates with no load, disassemble the wiring harness and connector, and then remove the screw that fixes the kneading and tapping motor with tools to replace the motor assembly.

9.5 Replace rocker arm assembly.

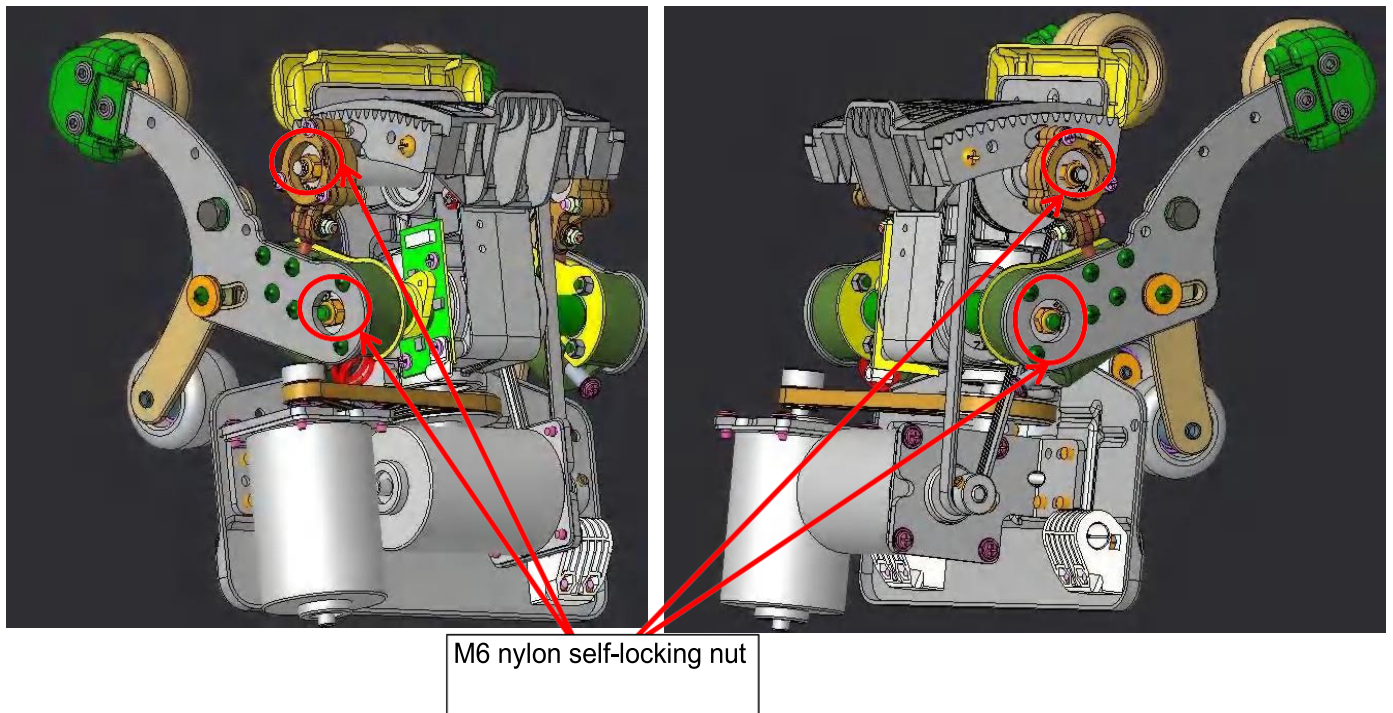

Remove the M6 nylon self-locking nuts that fix the left and right rocker arm assemblies with tools, and replace the left and right rocker arm assemblies. (When the nut is fixed, the thread of the shaft is coated with anaerobic glue, so it needs to be disassembled with powerful tools, and it needs to be coated with anaerobic glue again when it is fixed again to prevent the rocker

arm from falling off and loosening to cause abnormal sound. )

## 10. Replace the air pump assembly.

10.1 Use tools to cover the power supply box. Fix 3 screws remove the power box cover assembly.

10.2 Remove the air pump assembly in the power supply box.

10.2.1 Remove the screws fixing the air pump at 4 places with tools, clamp the air pipe clamp with pliers and unplug the air pipe, unplug the wire harness connecting the air pump, remove the air pump assembly in the power box and replace the air pump assembly.

10.3. Remove the air pump assembly under the seat.

10.3.1 First, remove the power box cover according to the procedure in 10.1, then remove the three screws fixed in the power box, unplug the connector,

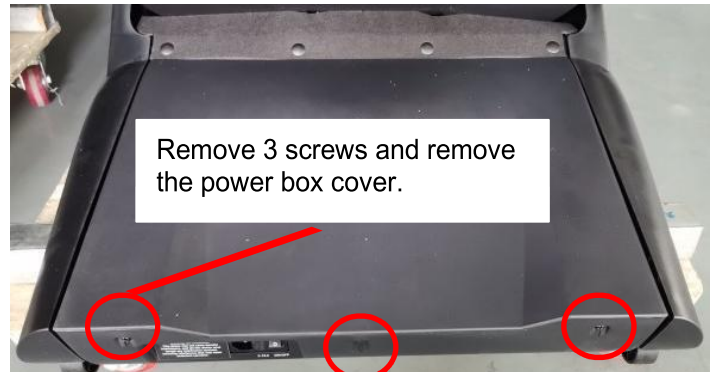

and

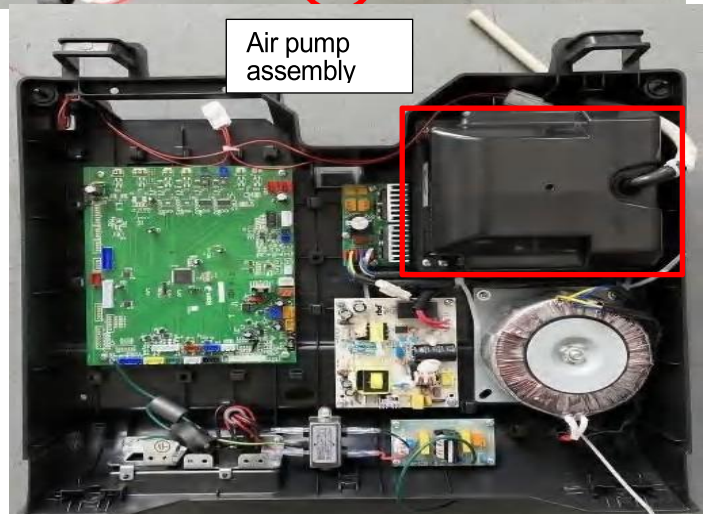

and shake the power box assembly left and right.

10.3.2As shown in the following figure: use tools to remove the screws at the 9 fixed side baffle, remove the left side baffle assembly, expose the air pump assembly on the chassis, and remove the fixed air pump connection.

Device and plug the wiring harness, remove the screws and air pipes fixing the air pump at 4 places, and replace the air pump assembly on the underframe.

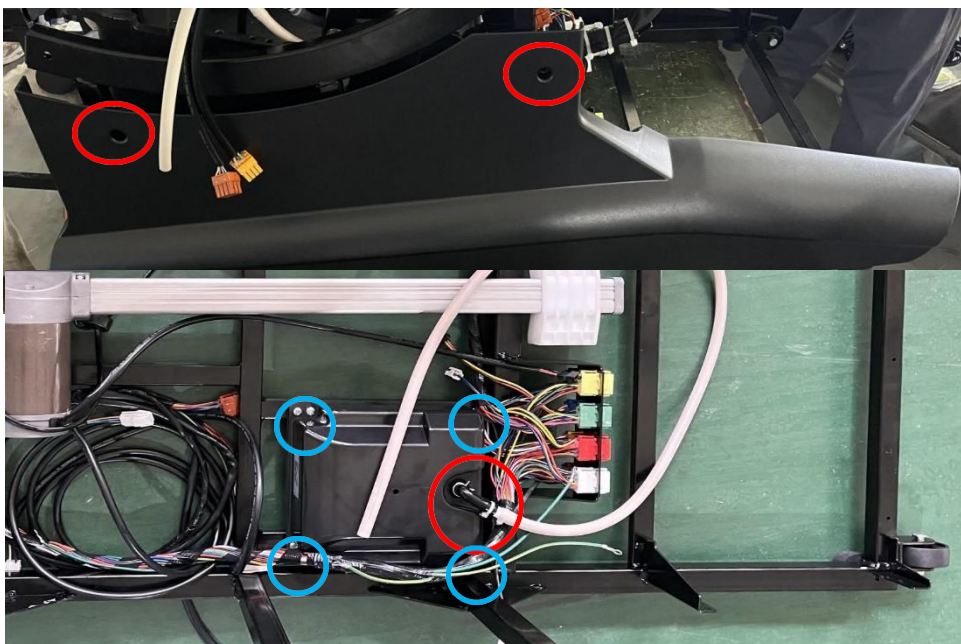

### IV. the main circuit board component layout

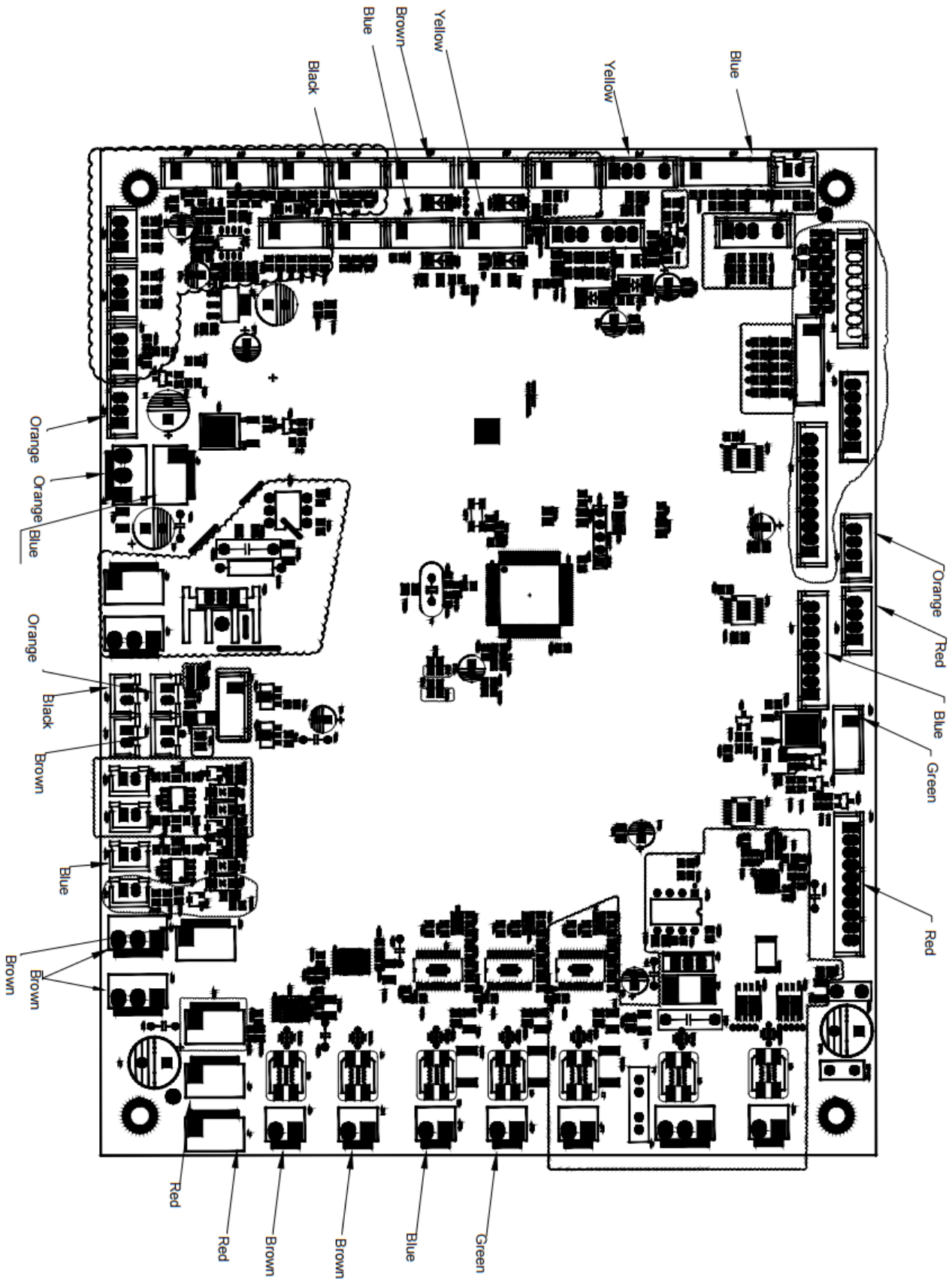

# V. System Connection Diagram

## MAIN PCB





# Leg PCB



### Upper and Lower Mech PCB (No heat on the lower mech PCB.)

