

RT-8720P massage chair

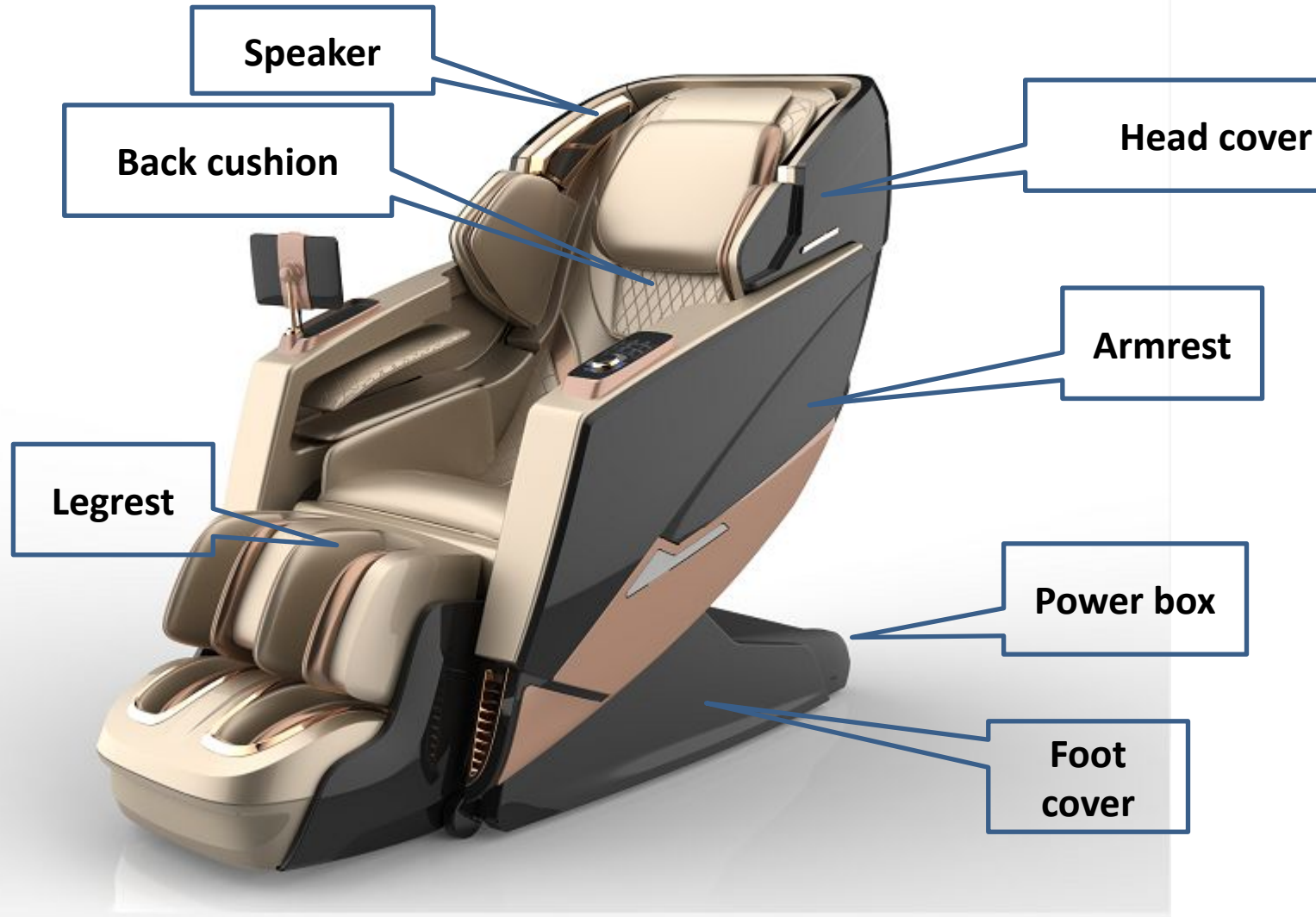

1. RT-8720P appearance



3D Force at 5 levels

Levels 1, 2 improve surface muscle relaxation,

The third gear is to massage deep into the muscles,

The 4th gear plays a role in pushing the muscles and bones.

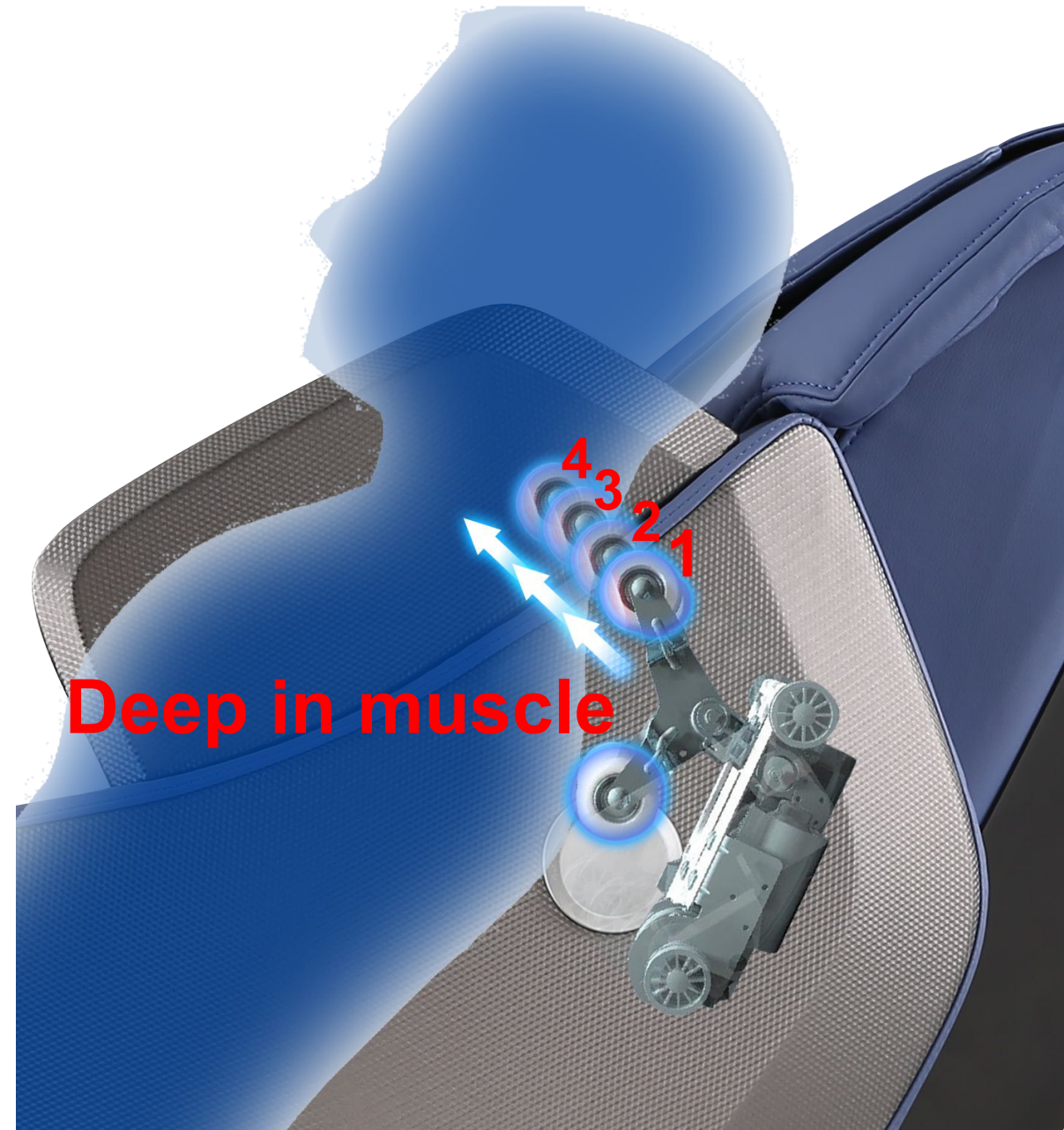

Dimension

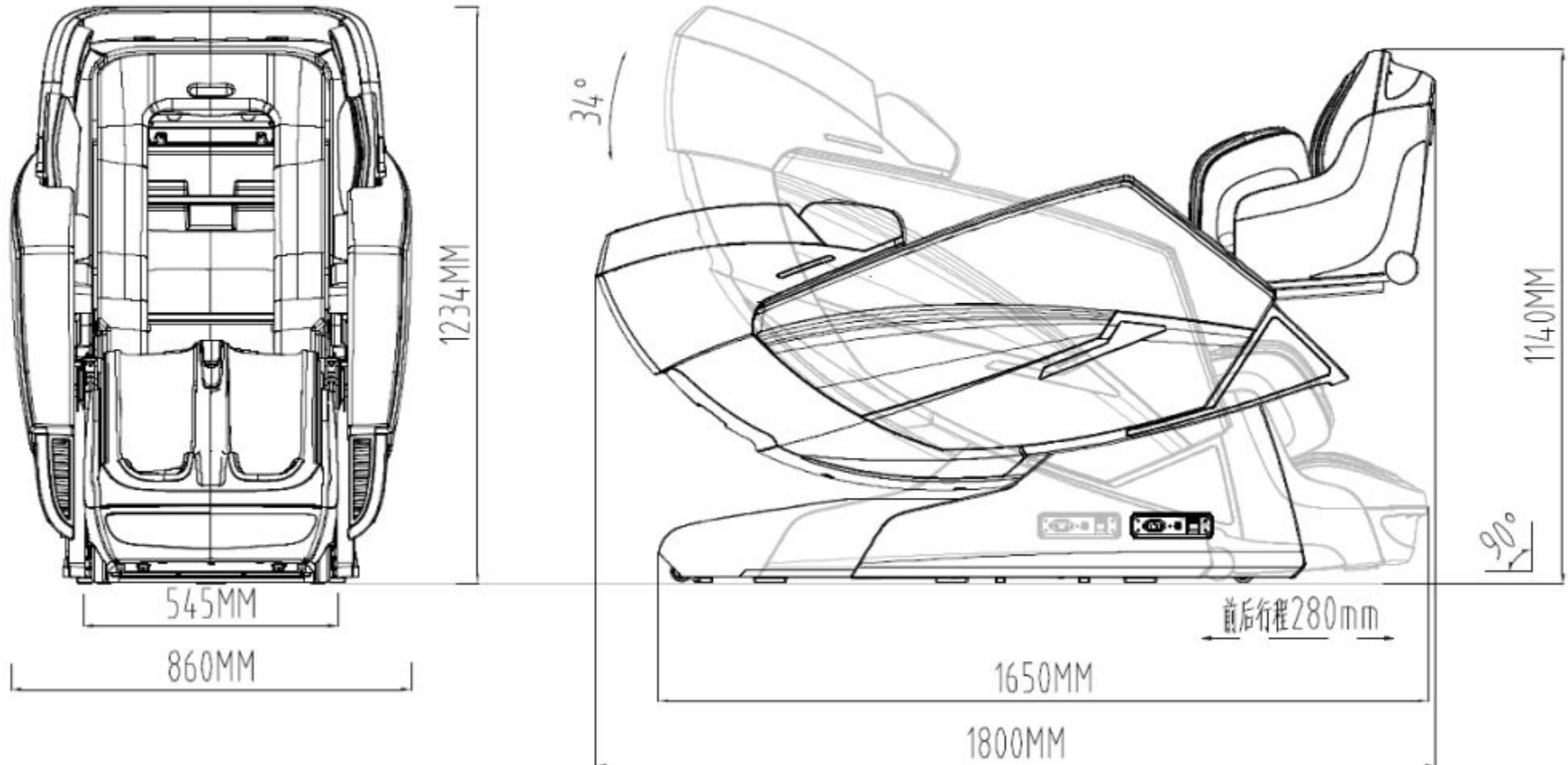

Common fault analysis & troubleshooting methods

1. Remote does not respond--

1. Replace the remote
2. Replace the power board
3. Replace the main board
4. Replace the user interface board
5. Replace the filter board

6. Replace the filter
7. Replace the fuse
8. Replace the power switch

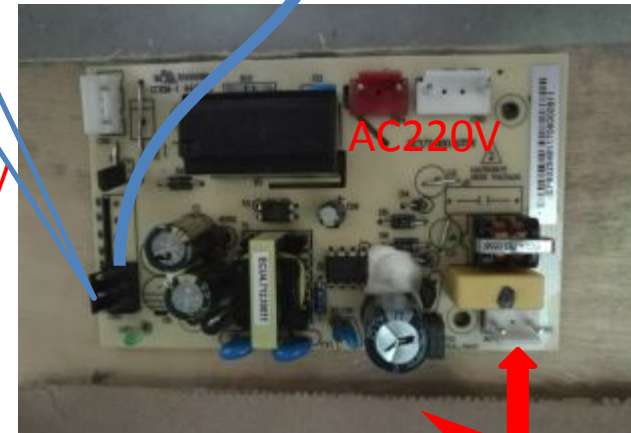
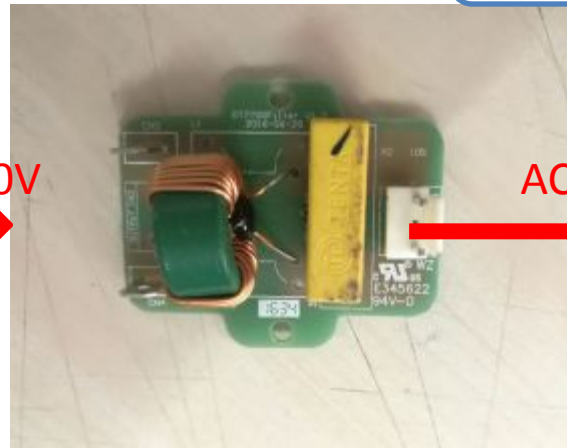
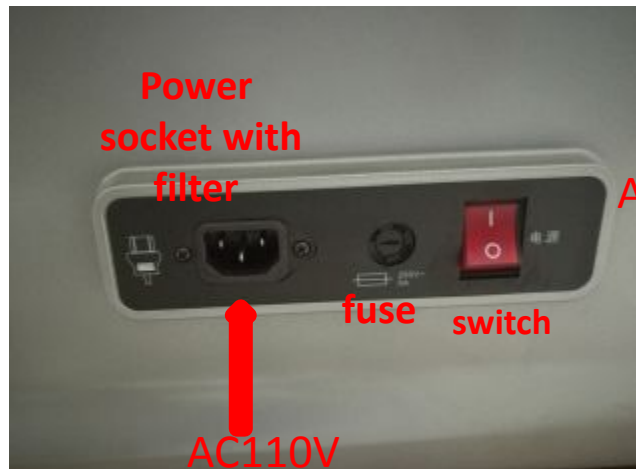
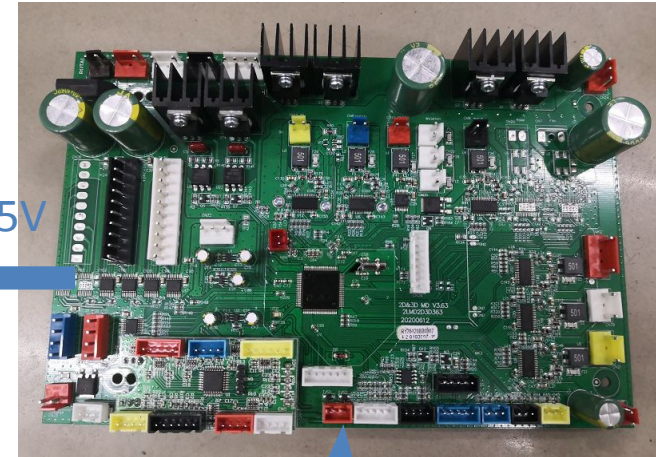

DC5V

DC5V

DC5V

DC5V
Joint

AC110V

AC110V

AC220V

AC110V

AC110V

2 Traveling motor does not work-manual and automatic functions do not travel

Remove the cover of the power supply box, turn on the machine and select the manual function of kneading and tapping synchronization method. Pull out the plug-in of the walking motor (black) and plug it into the tapping motor (red) socket. Observe whether the walking motor is moving.

No walking

1. Replace the walking motor
2. Replace the connecting wire

There is walking

1. Replace the main board
2. Up and down stroke detection board and stroke signal line

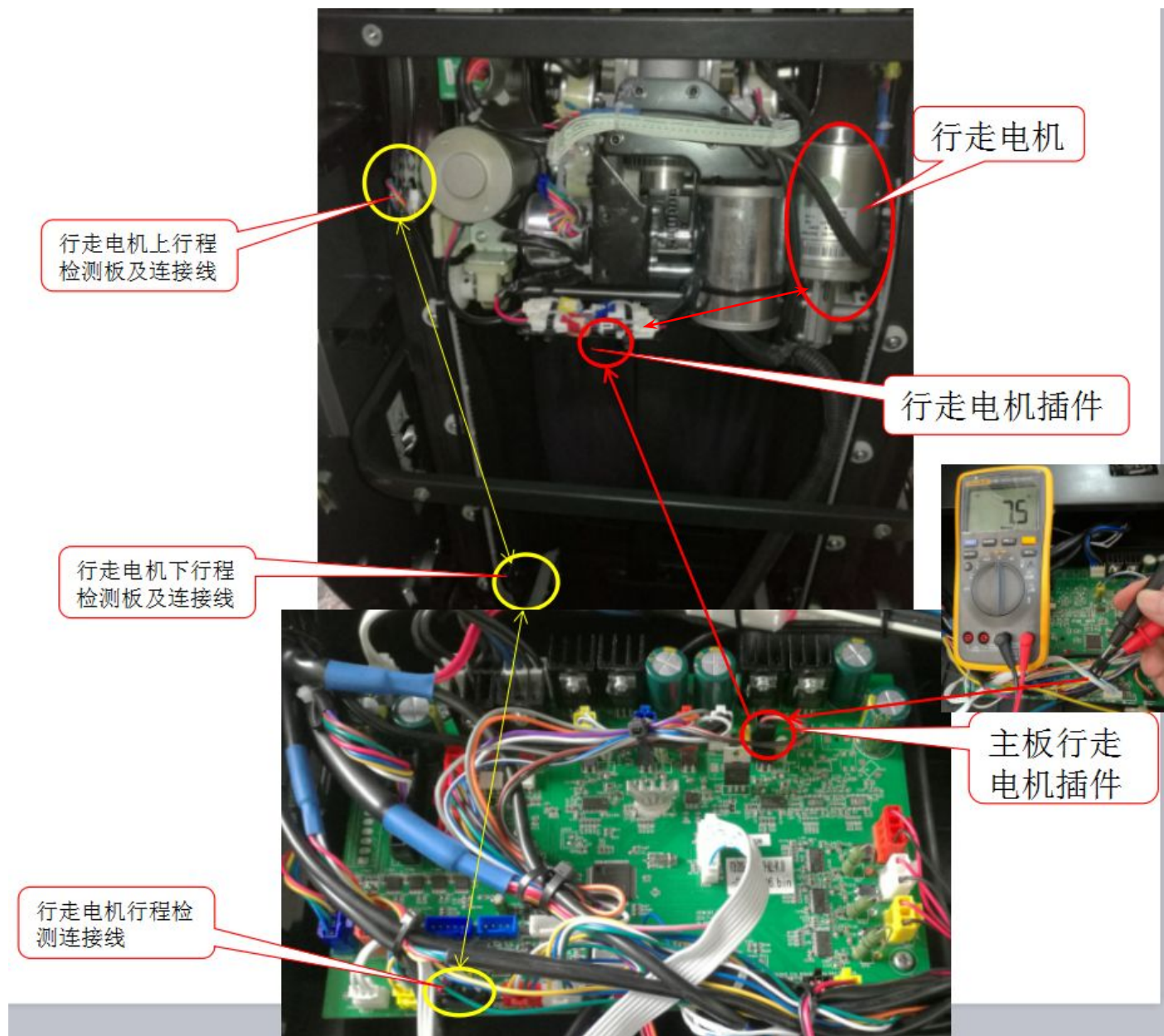

3. The motor without kneading and kneading function does not have a signal detection circuit, and it is relatively simple to judge.

Failure analysis—

No kneading—First, manually select the kneading and knocking synchronization method. When the knocking function is normal, pull out the blue plug-in on the motherboard and plug it into the red socket to see if the kneading motor works.

A. If Kneading works:
Replace the main PCB.

B. If no kneading:
1. Replace the motor
2. Replace the connecting wire

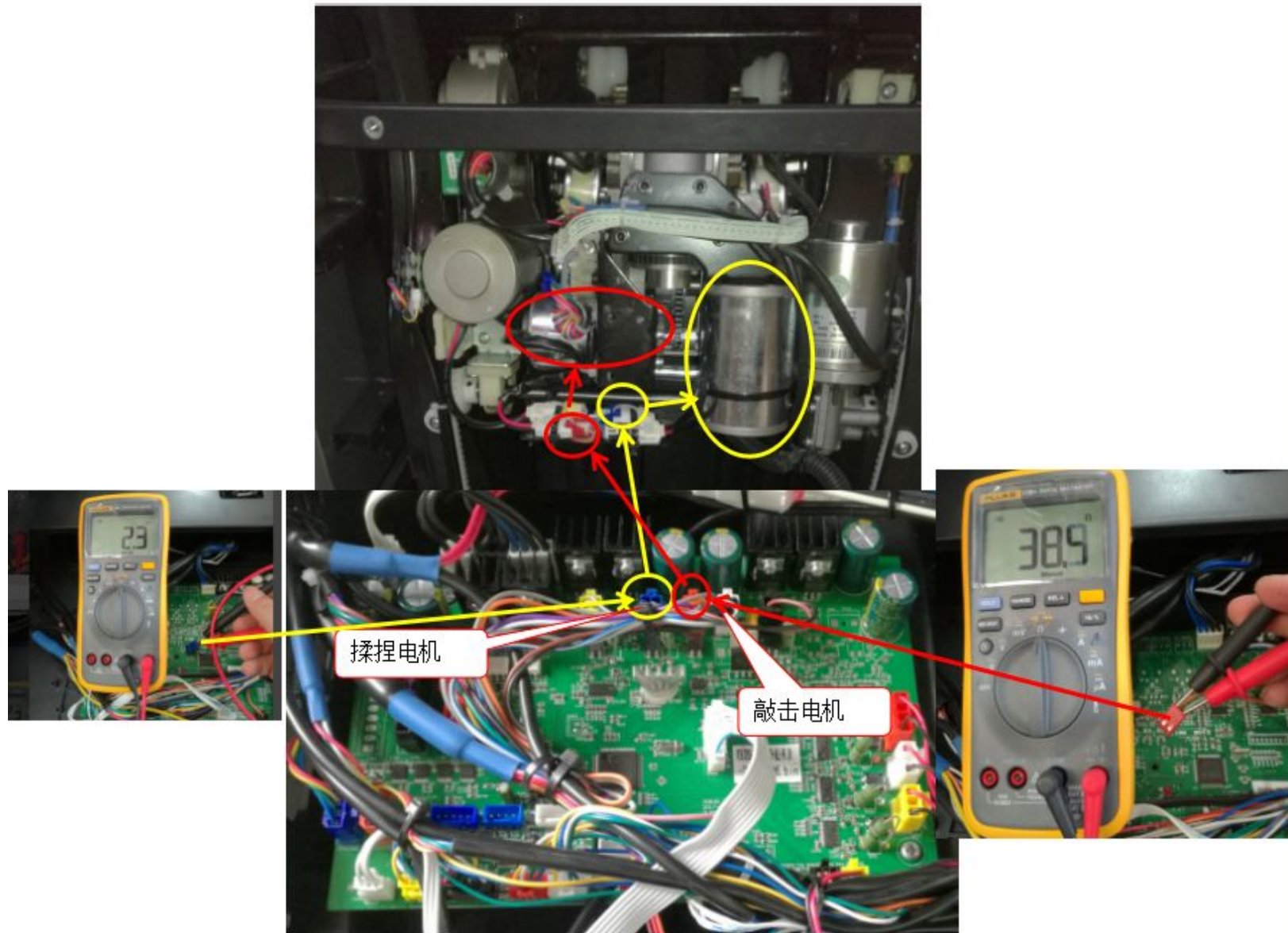

4 No percussion---percussion motor work requires wide, medium and narrow signal detection. Failure analysis—

No tapping-first manually select the kneading and tapping synchronization mode (there will be two phenomena)

1. Kneading and knocking work is normal: it means that the knocking motor and the connection line are normal. The problem lies in the wide, medium and narrow detection circuit. Check the wide, medium and narrow detection board, connection line, and 3D adapter board.
2. Only the kneading technique: Pull out the red plug-in on the motherboard and plug it into the blue socket, and see if the motor is knocked on or not.

1 Knocking works

Replace the main PCB

2 Knocking doesn't work

Replace the motor

Replace the connection line

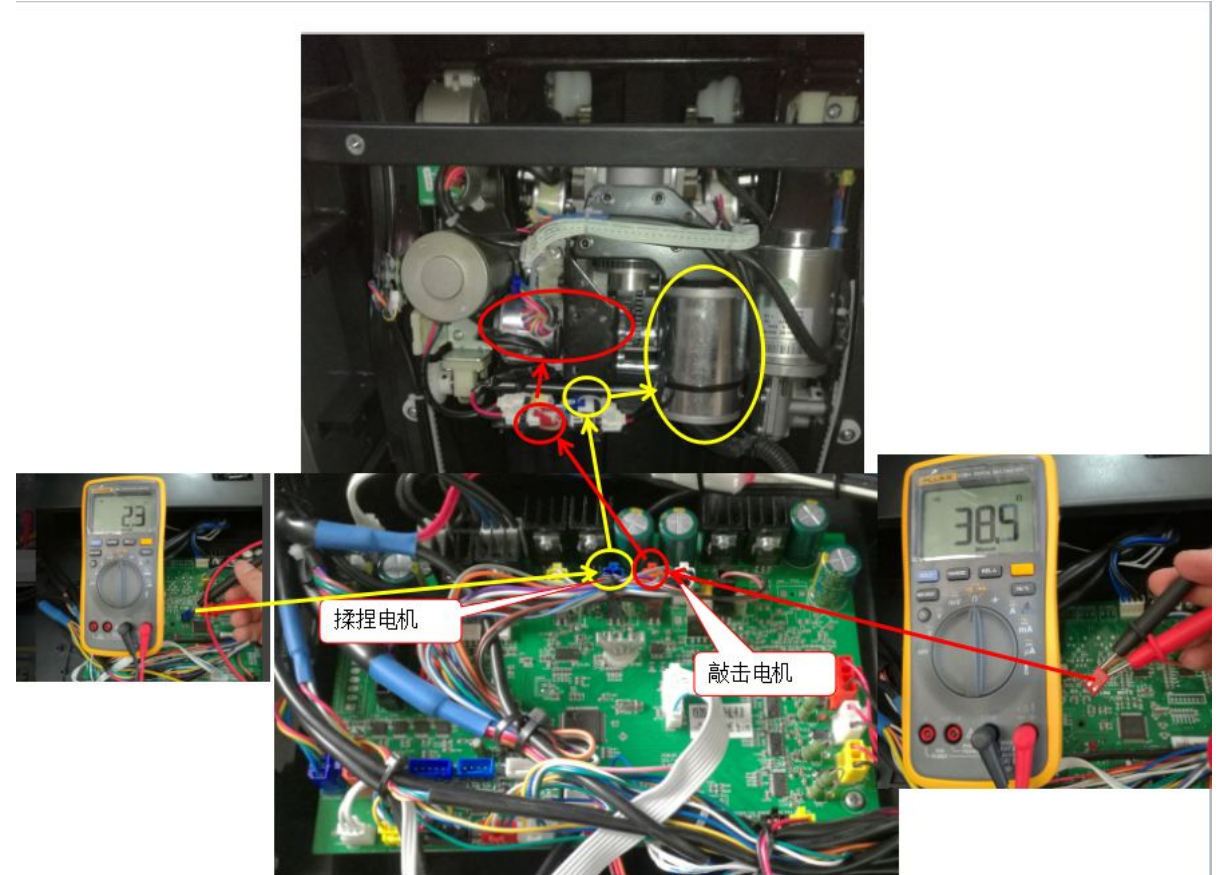

5. The electric cylinder does not work (the lower leg, backrest, front sliding electric cylinder)—First turn on the electric cylinder with normal function by turning on the hand controller, and use the exchange method to determine whether it is (the electric cylinder, the main board or the connecting wire is broken)

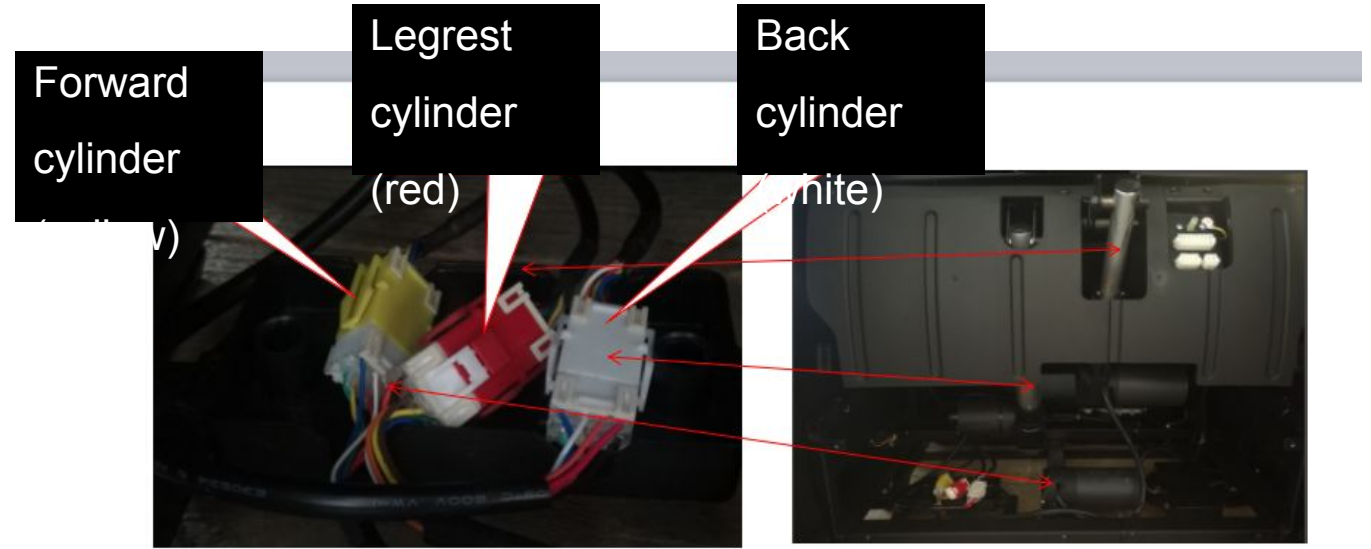

With lift

- 1. Replace the motherboard
- 2. Replace the connection line

No lift

- 1. Replace the same model electric cylinder
- 2. Replace the connection line



Legrest cylinder DC24V/80mm



Back cylinder (with Hall) DC24V/135mm



forward cylinder DC24V/280mm

6.No air pressure-no air pressure failure analysis of the whole body-

The massage chair works normally, but the whole machine has no air pressure. (Generally, the fault point is on the air supply circuit, such as the main board or AC19V air valve power supply.) The hand controller manually turns on the whole body air bag to observe whether the air pump vibrates. Find the corresponding air bag, trachea, and valve for a single part without air pressure.

No vibration

1. Replace the air pump
2. Replace the motherboard

Vibration

1. Replace the transformer
2. Replace the motherboard

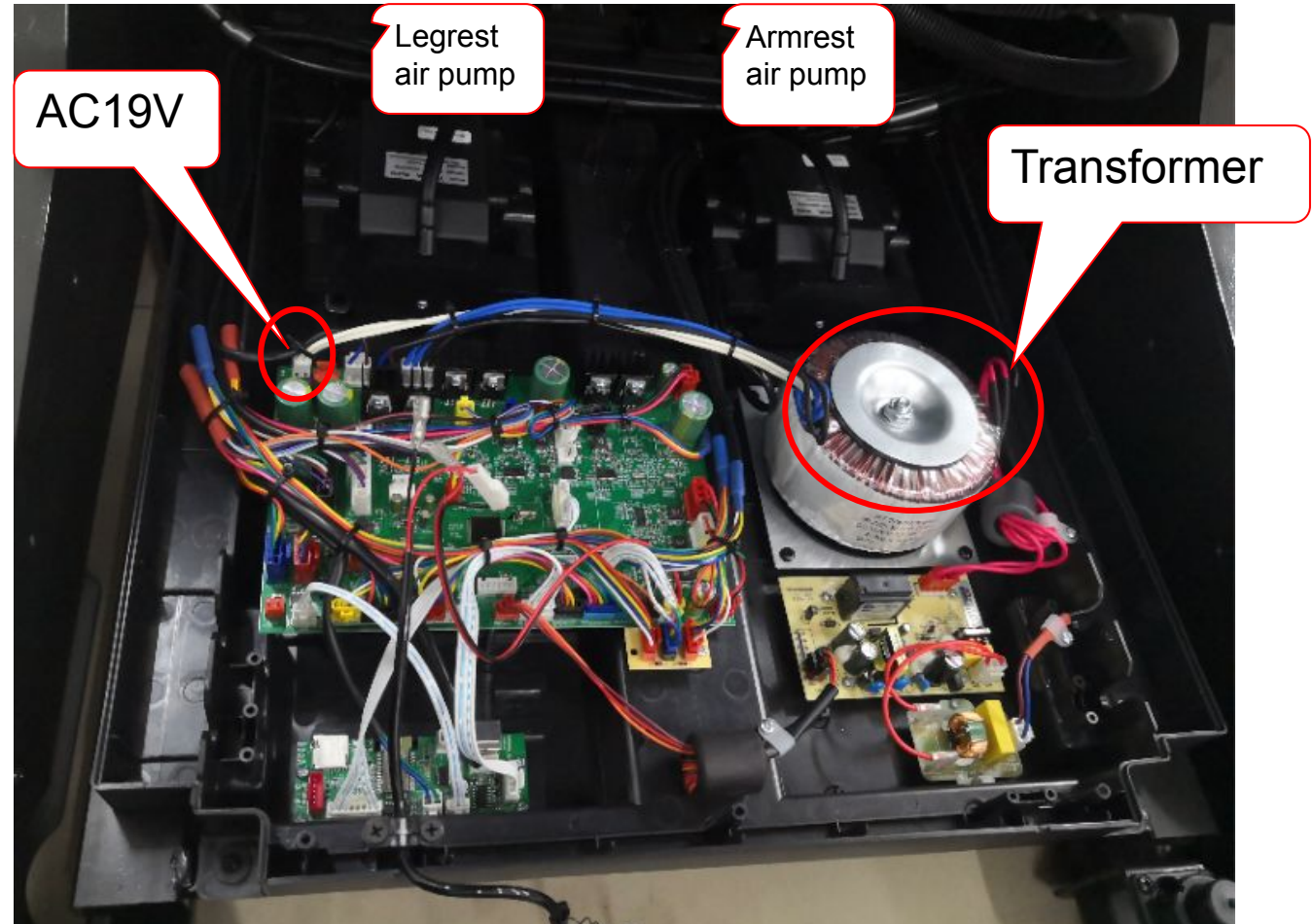

7. No music-(noise when the speaker stands by)

When the hand control board is turned on and the machine is working, the Bluetooth of the mobile phone searches for the Bluetooth of the machine, and it is paired. If it fails to connect or cannot be paired (you can't find it after changing the phone), it means that the Bluetooth board or main board is broken. Replace the Bluetooth board or main board.

1. Replace the Bluetooth board
2. Replace the motherboard
3. Replace the speaker
4. Replace the audio signal cable

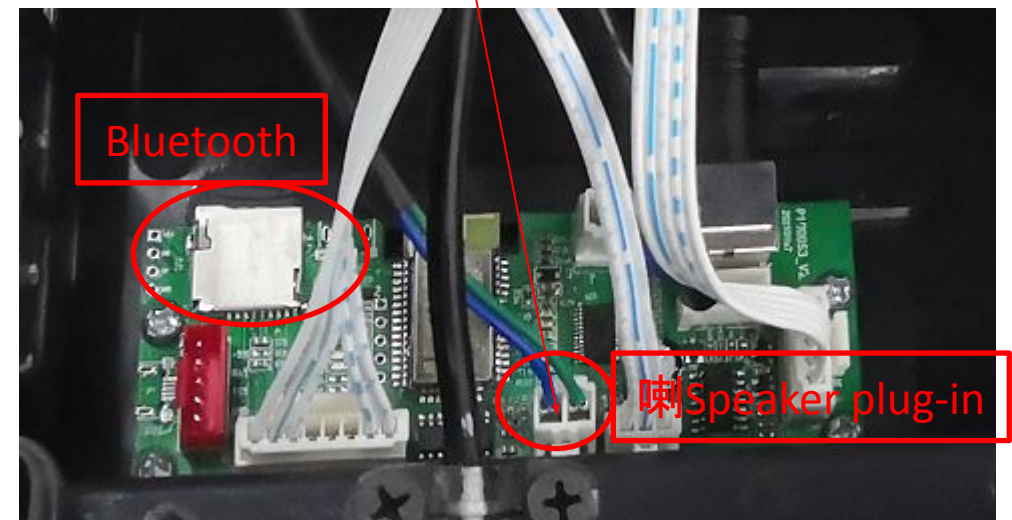

8. The reason why the calf telescopic motor does not work is divided into-

Turn on the hand control board to turn on the roller function, and insert the telescopic motor plug-in (red) into the roller motor socket (black) and the anti-flash stroke is instantly energized to see if the motor is working--

Not working

1. Replace the motor.

Able to move

1. Replace the calf main board
2. Replace the up and down stroke detection board

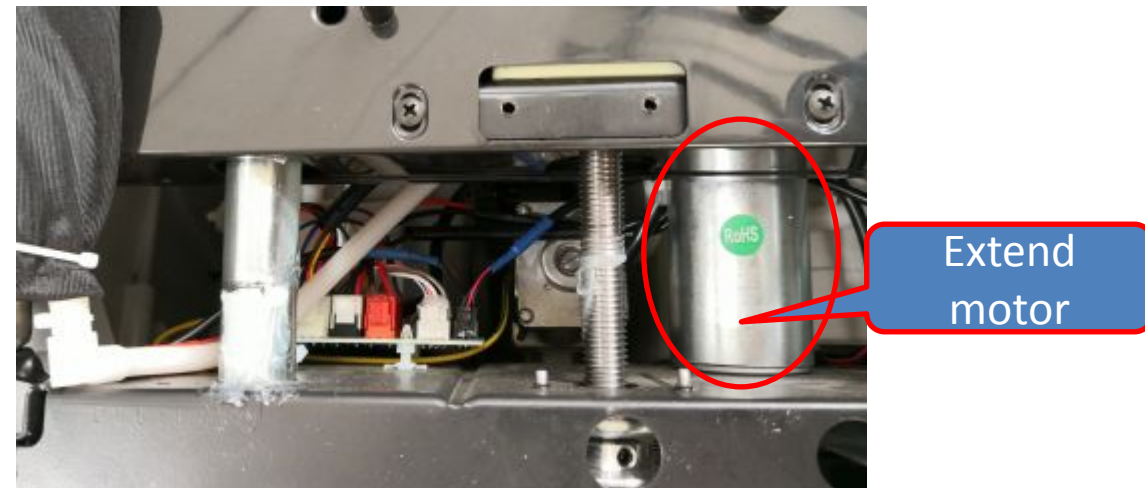
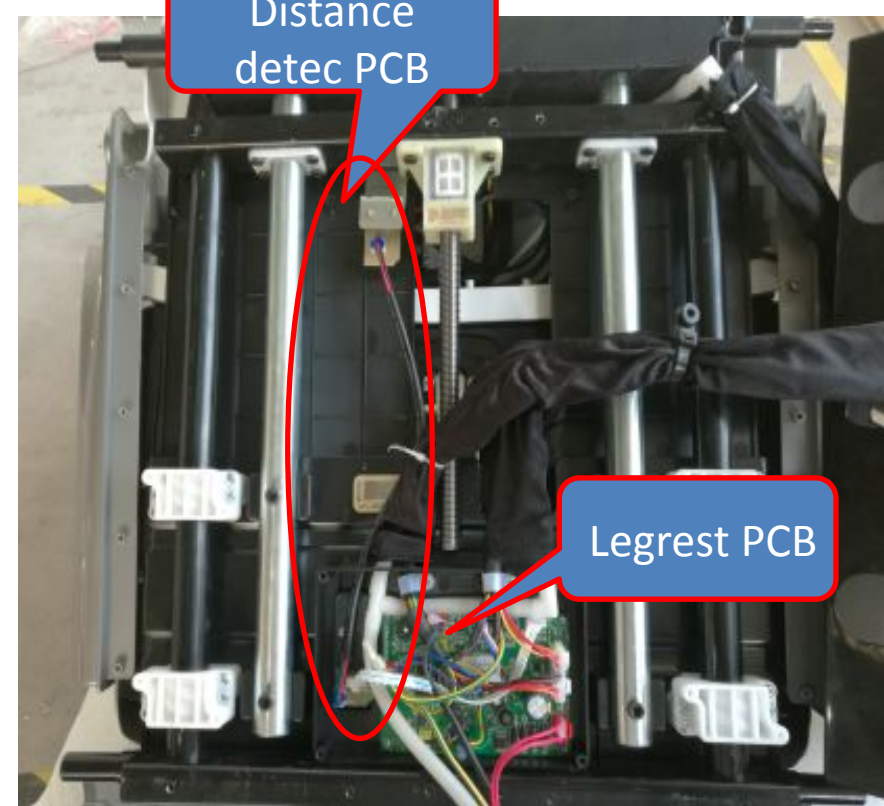

9 "Didi" alarm sound in the calf when the machine is turned on. Solution

1. Check whether the calf communication signal line is in good contact with the host, and fix it again if it is defective.
2. Open the back cover and observe whether the connecting wires of the anti-pinch sensor switch on both sides of the lower leg are loose or fall off, and then fix it again.
3. Check whether the foot transfer communication signal line is in good contact. Or the safety sensor switch plug-in is loose and can be fixed again.
4. The above test is normal, replace the calf main board.

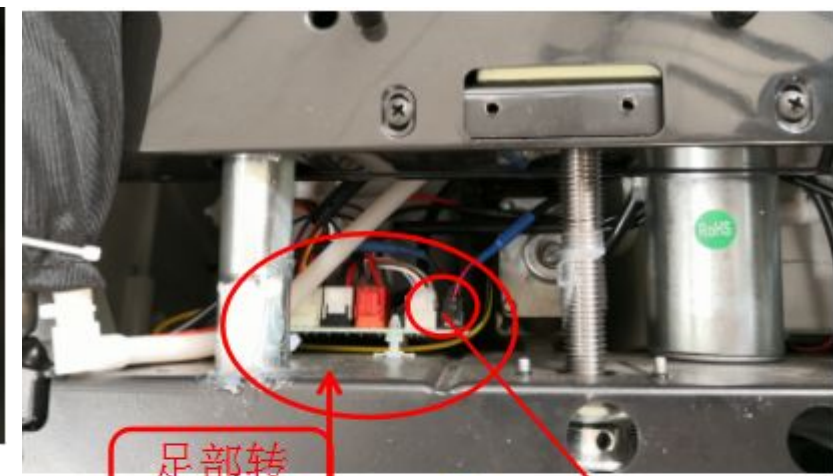

10. The key board cannot be used-troubleshooting method

1. Check whether the communication signal line of the key board is in good contact with the host, and fix it again if it is defective.
2. Check whether the keys on the key board have card masters and no flexibility, just disassemble and re-adjust.
3. Open the cover of the key board, observe whether the connection line of the key board is loose or fall off, and fix it again.
4. The above test is normal, replace the key board.



11. Wireless charging can't charge troubleshooting method

1. Check whether the armrest charging plug-in cable is in good contact with the host, and fix it again if it is defective.
2. Open the cover of the charging board, observe whether the charging board connection line is loose or fall off, and fix it again.
3. The multimeter detects whether the charging board has DC24V voltage, replaces the charging board, does not detect whether the connection line is on or off, detects the DC24V output of the mainboard charging plug-in, and replaces the mainboard.

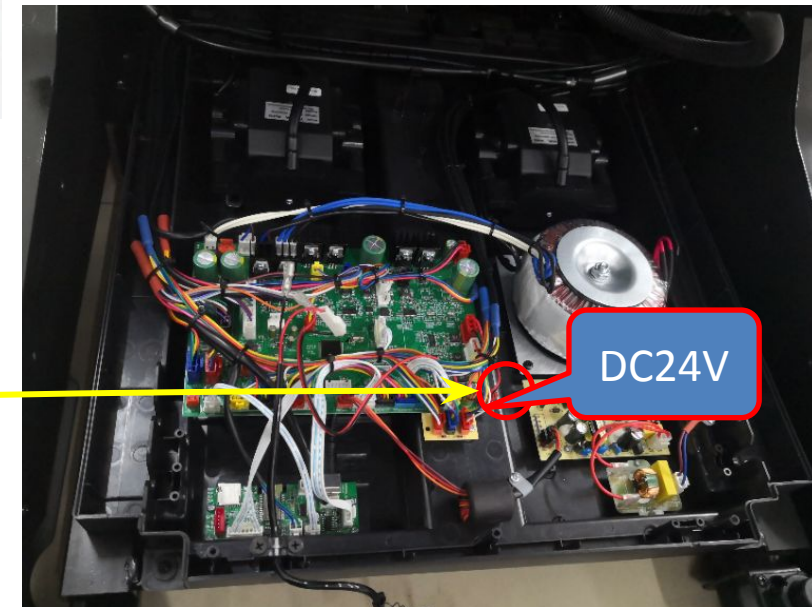
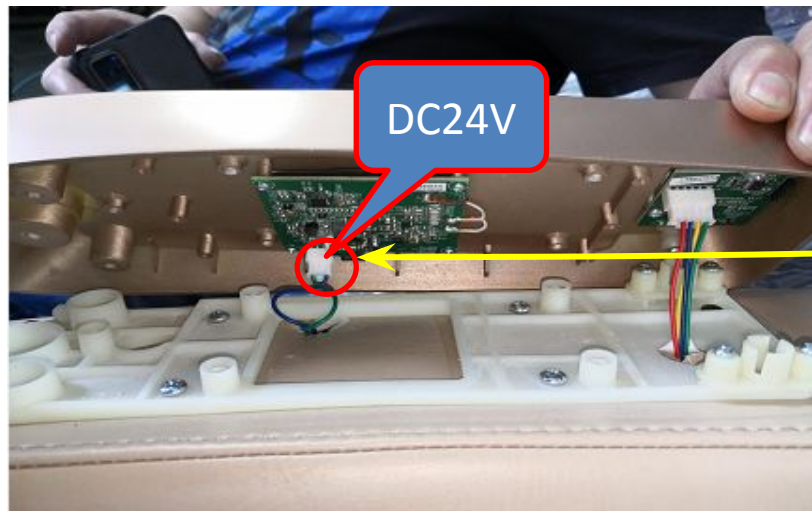

Main accessories of electrical control cabinet

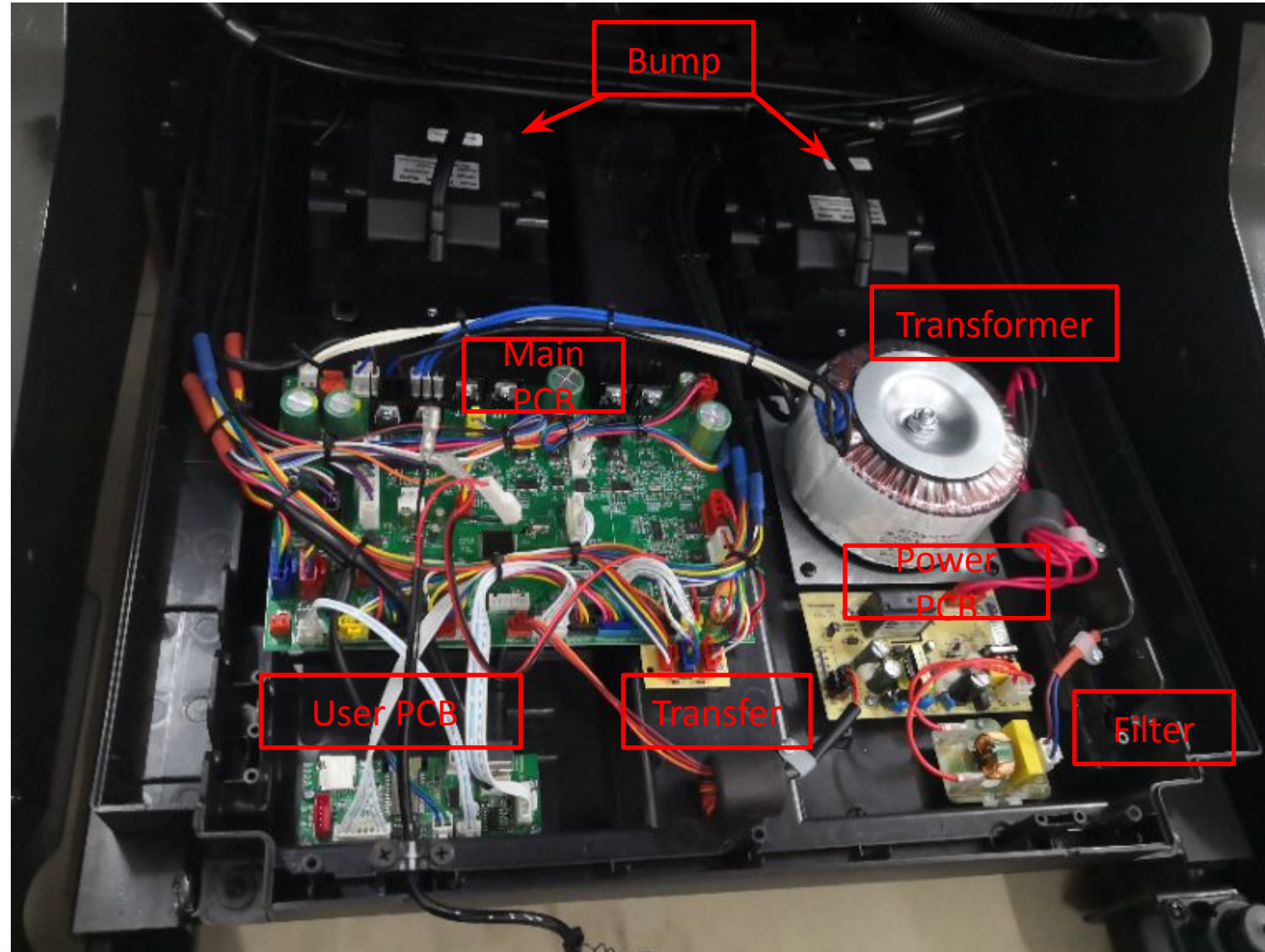

Motherboard plug-in diagram

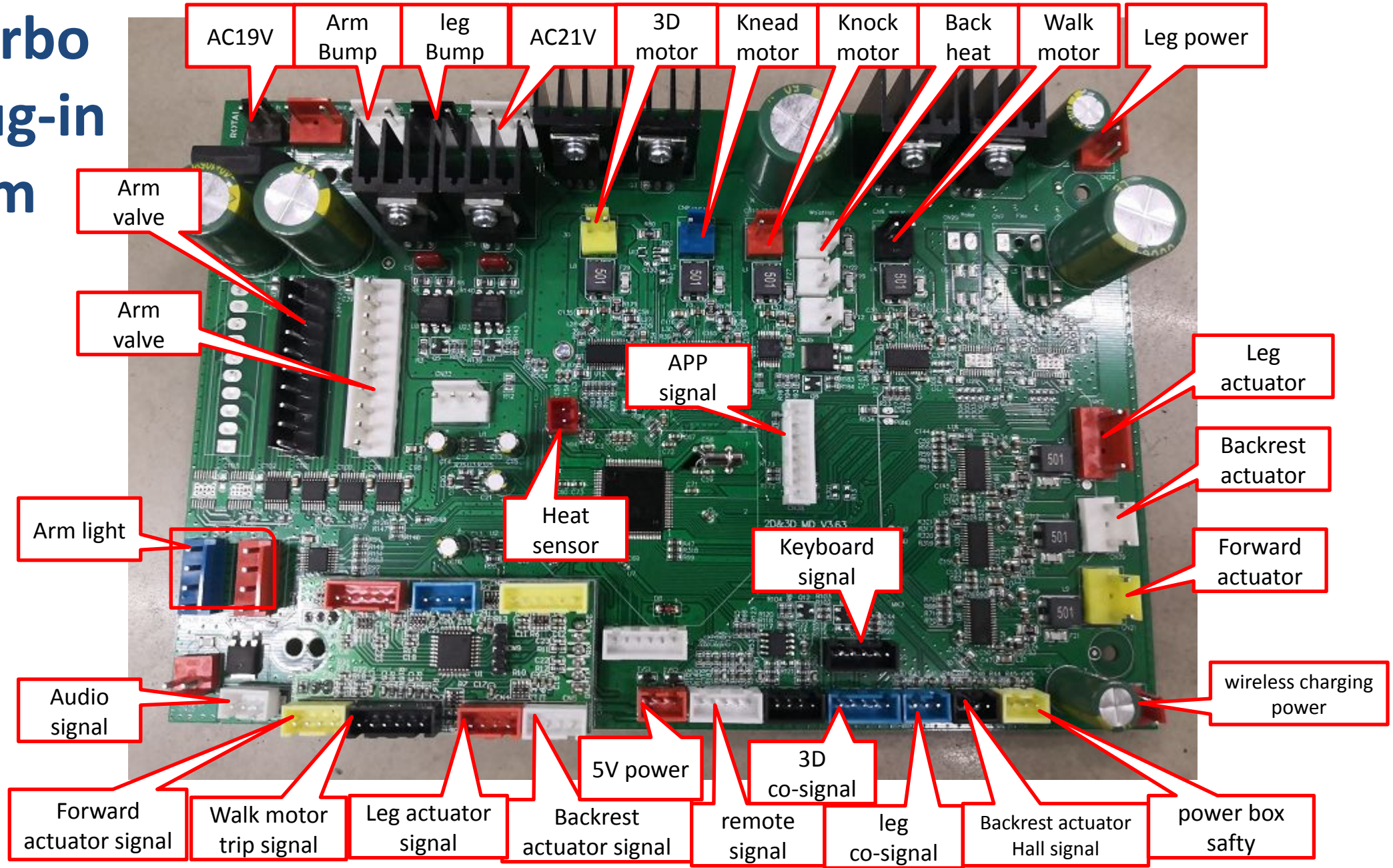

Schematic diagram of user adapter board plug-in

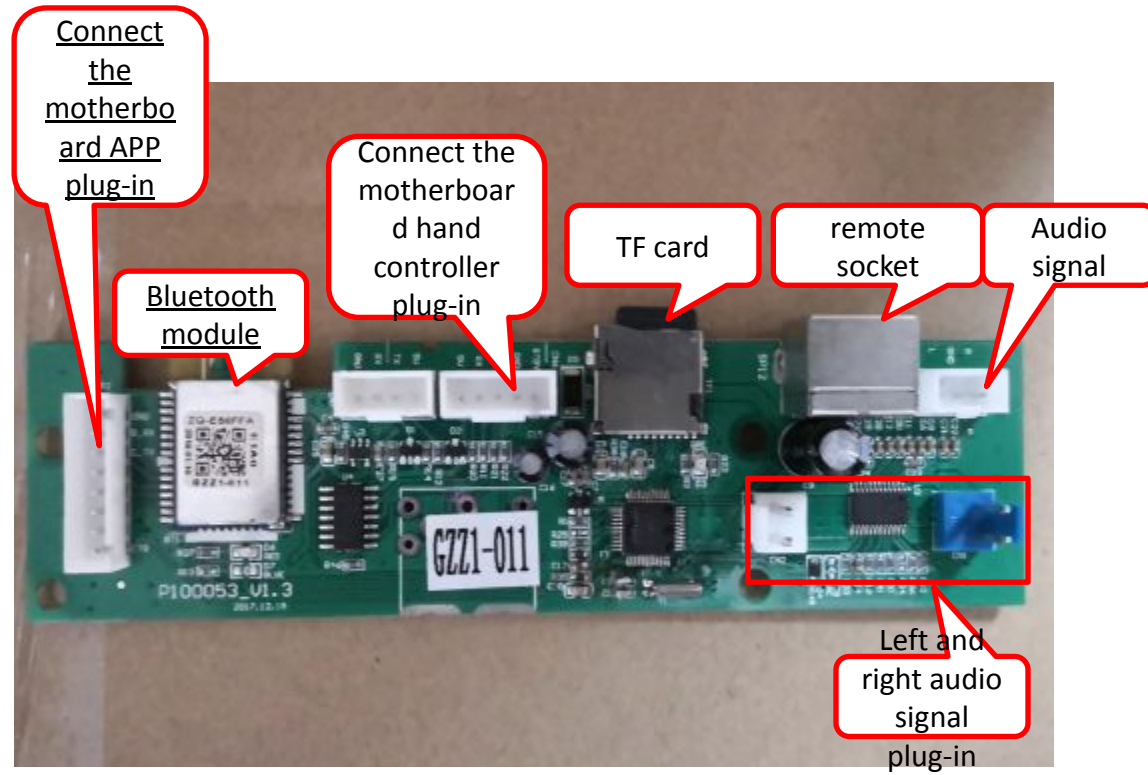

Schematic diagram of the calf motherboard plug-in

Roller motor

滚轮电机接口

揉搓电机接口

Leg knead motor

AC21V 接口

Foot valve

脚部气阀接口

Calf valve

腿部气阀接口

Extend motor

伸缩电机接口

小腿角度检测板

Legrest angle detect

小腿伸缩电机行程检测信号接口

Leg extend motor signal

揉搓电机计数信号接口

Leg knead motor signal

脚部通讯信号接口

Foot co-signal

小腿通讯信号接口

Calf co-signal

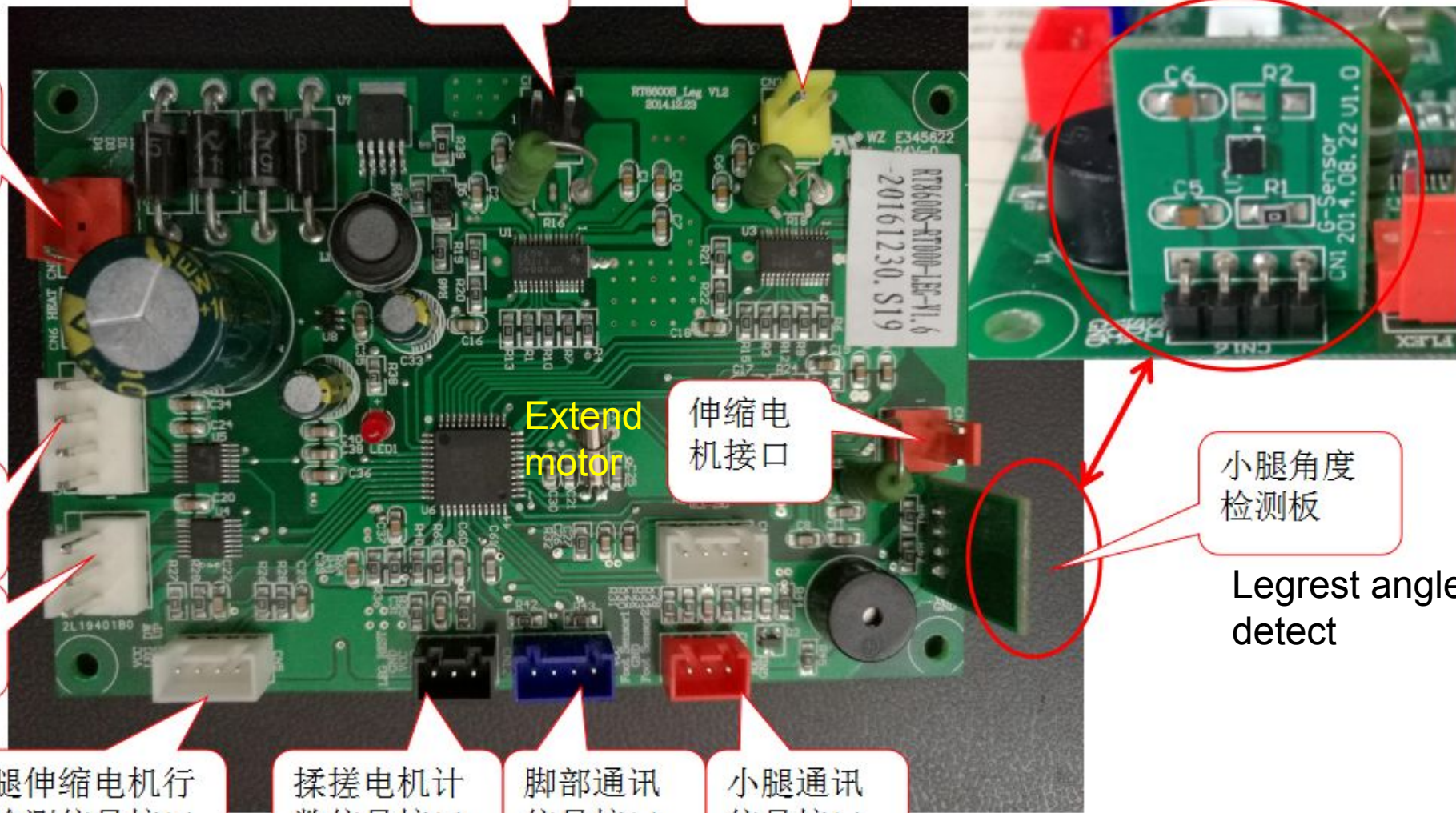

Schematic diagram of wireless charging board plug-in

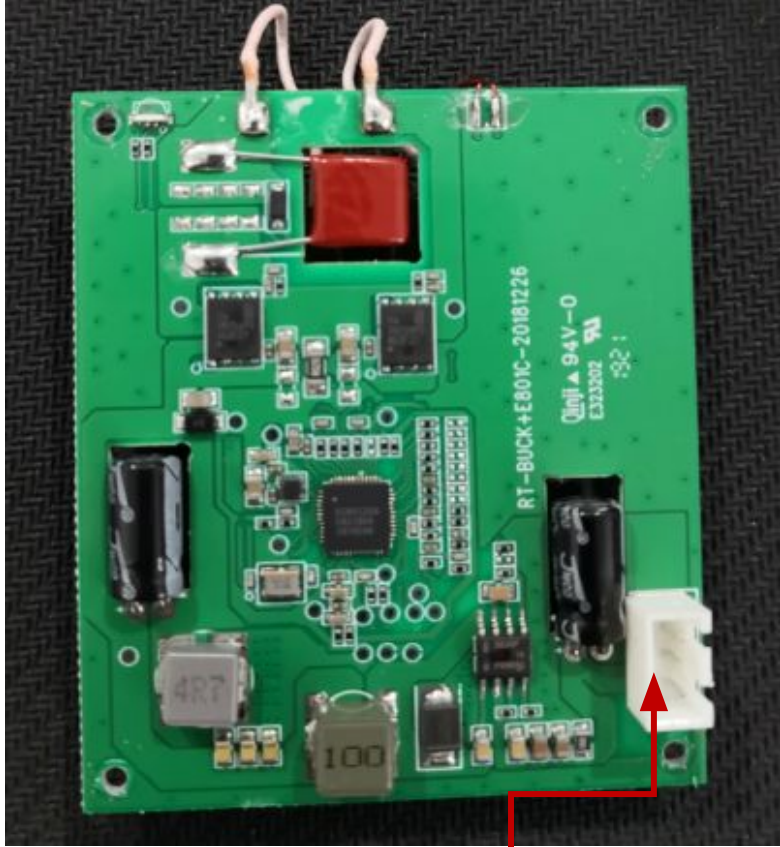

DC24V

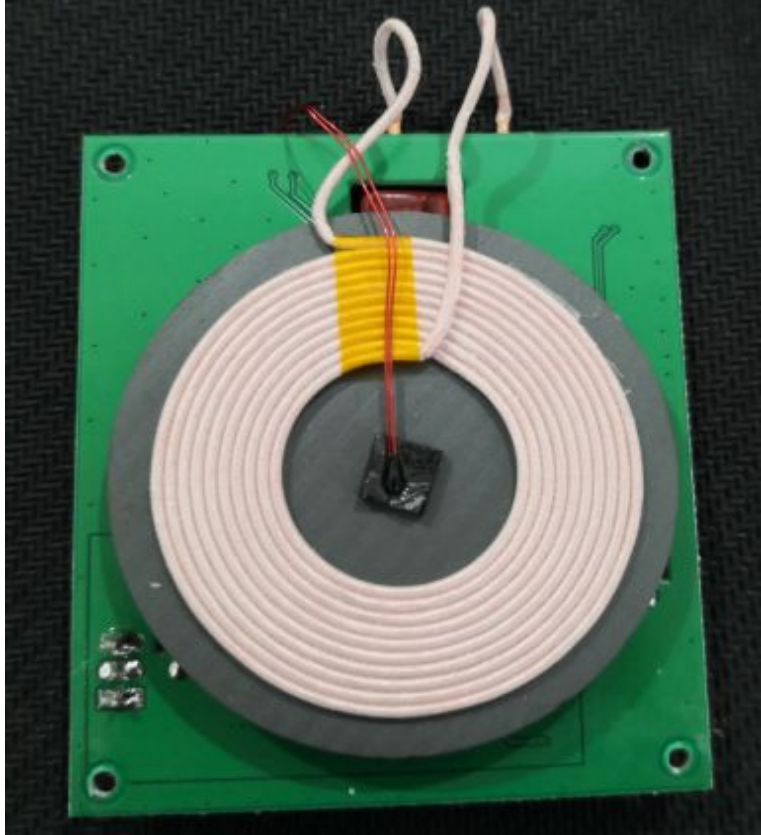

- **3D communication board plug-in schematic diagram**

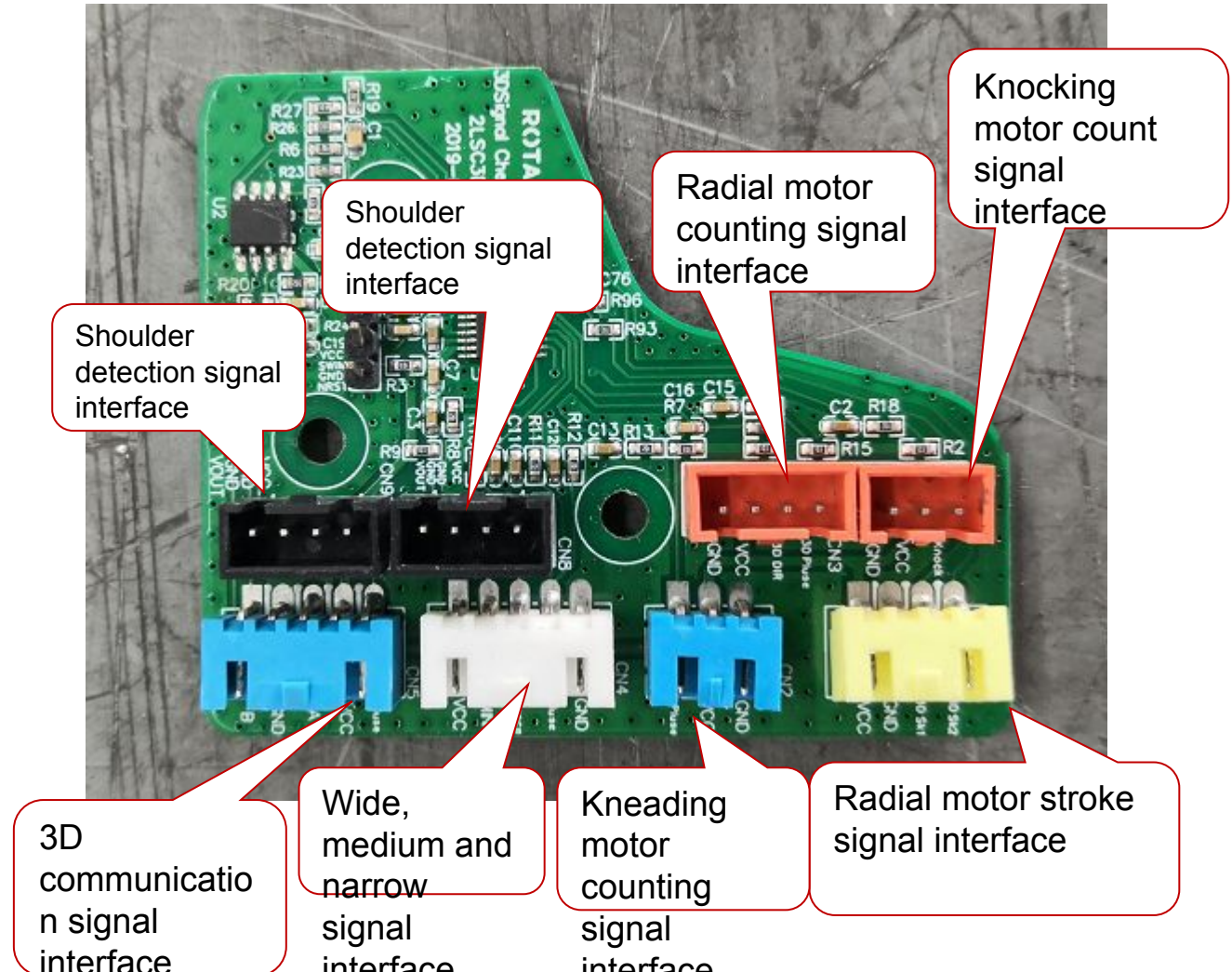

Wide, medium and narrow detection board

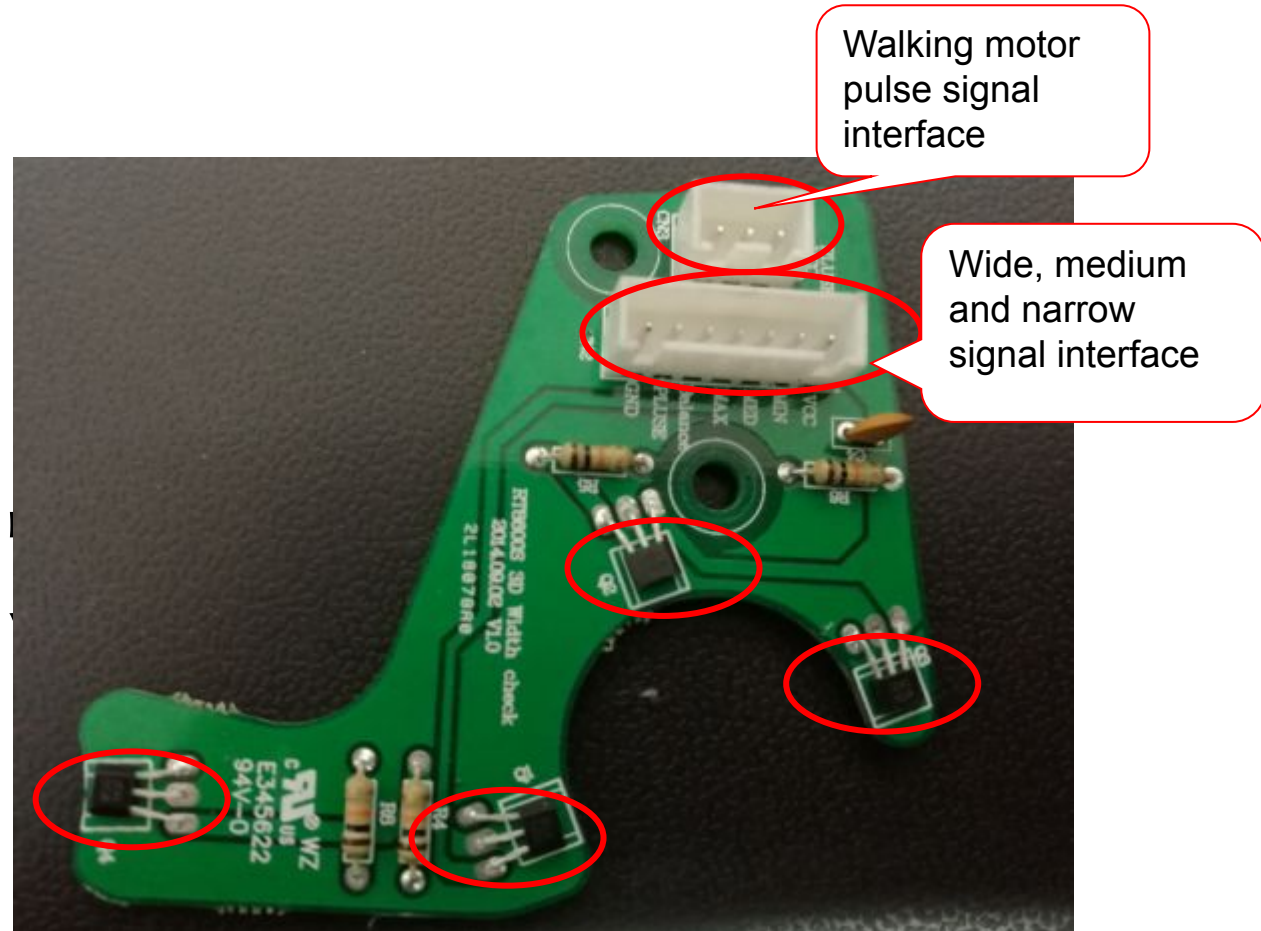

Q1 wide 、 Q2 medium、 Q3
narrow、 Q4Arm balance

- **Radial motor stroke detection (Q1 before Q2)**

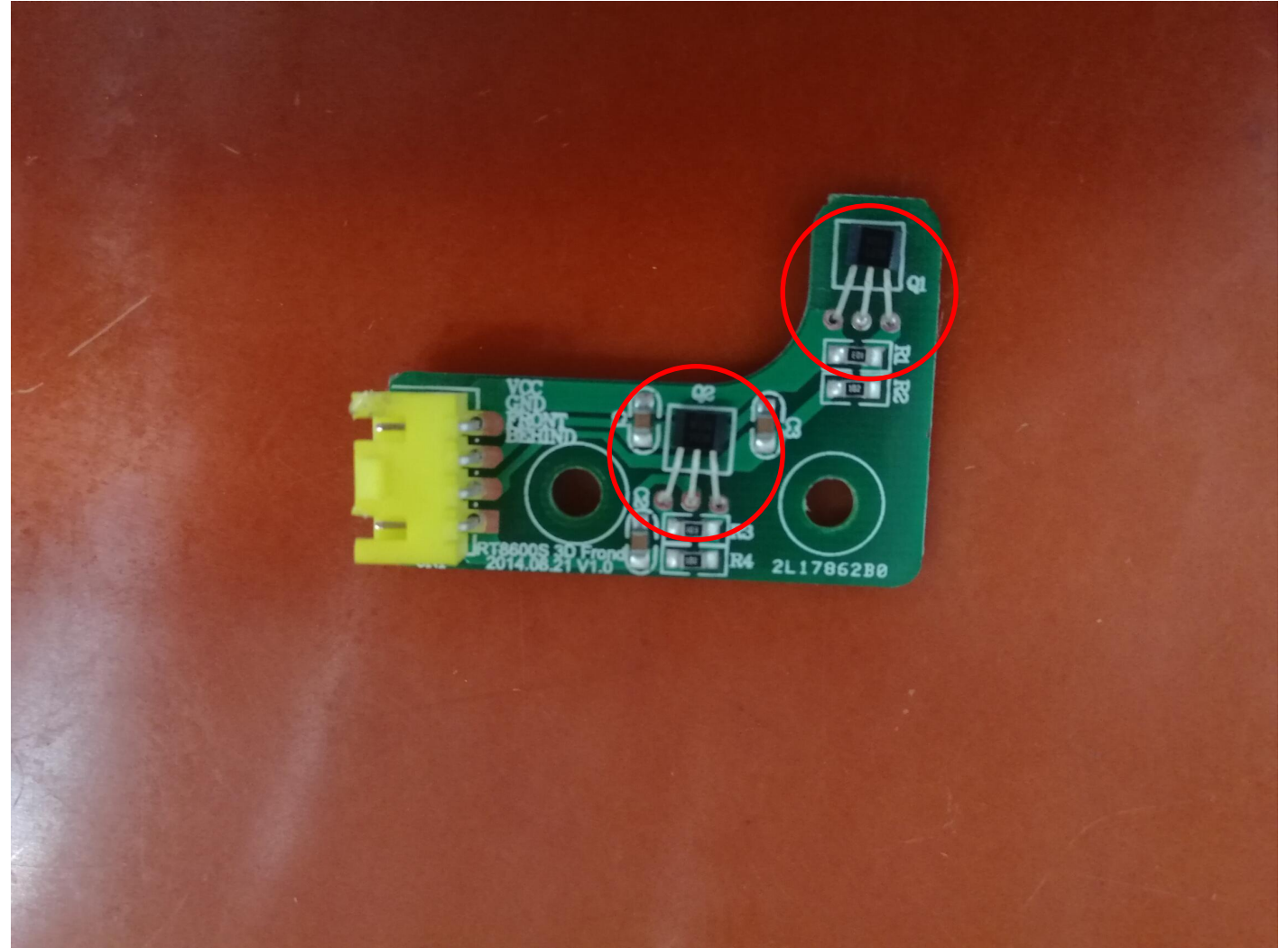



Thank you!