



蒙发利

EASEPAL

中国·厦门蒙发利科技有限公司

Xiamen Comfort Science & Technology Co.,Ltd

产品维修手册

Maintenance Service Manual

产品型号/MODEL: EC-621C

适用电压规格/ voltage specification: 110-120V

蒙发利集团·客服

By the Easepal's Customer Service Dept.

一、产品故障列表 Trouble List

如下为EC-621C常见的故障现象及维修方法。

Common Troubles and Maintenance Methods are listed as below:

故障序号NO	现象 phenomenon	描述 Description	维修方法 maintenance method
01	开机无功能 No function	A. 手控器无显示: LCD NO DISPLAY ①、保险丝烧掉Fuse melts (电源盒处和中心板上 (in the Power Source Box and main PCB) ②、电源电路接触不良。Power supply	①、更换保险丝 Replace Fuse ②、更换电源盒 Replace Power Box ③、更换电源滤波器 Replace EMC Board ④、更换中心板 Replace main PCB

		<p>circuit Poorly connected</p> <p>③、电源滤波器坏 EMC Board Failed</p> <p>④、中心板坏 Main PCB failed</p>	
		<p>B. 手控器有显示: LCD HAS DISPLAY</p> <p>①、机械开关坏掉 或是机械开关的线材断开。 Mechanical switch fails or it' s wire is broken</p> <p>②、上下行程光电坏。 Up or Down Stroke Photoelectricity was failed</p> <p>③、中心板坏掉 Main PCB failed</p> <p>④、开机直揉捏其他按键无效 kneading all the time from powerand no response with other button</p>	<p>①、更换机械开关或是线材 replace mechanical switch or wire</p> <p>②、更换行程光电 Replace stroke photoelecruicity</p> <p>③、更换中心板 Replace main PCB</p> <p>④、宽度检测板坏， 更换宽度检测板 Replace Width Inspection Board</p>
02	<p>宽中窄不能切换 the Width switchover isn` t change</p>	<p>①、中心板宽度检测端子线材接触不良。The terminals of Width Inspection on main PCB with wires were poorly connected</p> <p>②、机芯宽度检测板端子线材接触不良。The terminals of Width Inspection on mechanical with wires were poorly connected</p> <p>③、宽度检测板坏。 Width Inspection failed</p> <p>④、中心板坏Main PCB failed</p>	<p>①、②点将端子接插到位或是更换线 材Plug the terminals well or replace the wires</p> <p>③、更换宽度检测板 Replace Width Inspection</p> <p>④、更换中心板 Replace the main PCB</p>

03	不行走 NO Rolling	端子或是线材接触不良 Terminals or Wire Poorly Contact ②、上、下行程光电组件坏。 UP/ Down-stroke Photoelectricity Subassembly Failed ③、行走电机坏 Rolling Motor Failed ④、中心板坏 Main PCB failed	①、将端子接插到位或是更换线材。 Plug the terminal well or replace the wires 更换上、下行程组件 Replace UP/Down-Stroke Subassembly ③、更换机芯。 Replace gear box ④、更换中心板 Replace main PCB
04	不揉捏 No kneading	①、中心板端子没插到位或是线材接触不良。The terminals on main PCB and wires are poorly connected 、揉捏电机坏 Kneading motor failed ③、中心板坏 Main PCB failed	①、将端子接插到位或是更换线材。 Plug the terminal well or replace the wires ②、更换机芯 Replace gear box ③、更换中心板。 Replace main PCB
05	不敲击 No tapping	①、中心板端子没插到位 The terminals on main PCB and wires are poorly connected ②、敲击电机坏 Tapping motor failed ③、中心板坏掉 Main PCB failed	①、将端子接插到位 Plug the terminal well ②、更换机芯 Replace gear box ③、更换中心板R Replace main PCB
06	手控器上按键无反映 The all buttons of controller aren't response	①、端子接触不良或线材接触不良 The terminals and wires are poorly connected ②、手控器PCB板坏 The PCB in the controller failed	①、将端子接插到位或是更换线材。 Plug the terminal well or replace the wires ②、更换手控器 Replace the controller
07	不升倒背 backrest can't recline or lift	①、电动推杆连接线未接插到位 The terminal of electrically operated pusher and wires are poorly connected	①、将连接线接插到位 Plug the terminal well ②、更换电动推杆 Replace the electrically

		<p>②、电动推杆坏</p> <p>The electrically operated pusher failed</p> <p>③、中心板坏</p> <p>Main PCB failed</p>	<p>operated pusher</p> <p>③、更换中心板</p> <p>Replace main PCB</p>
08	<p>小腿不能升降</p> <p>calves-rest can't lift or recline</p>	<p>①、电动推杆连接线未接插到位</p> <p>The terminal of electrically operated pusher and wires are poorly connected</p> <p>②、电动推杆坏</p> <p>The electrically operated pusher failed</p> <p>③、中心板坏Main PCB failed</p>	<p>①、将连接线接插到位</p> <p>Plug the terminal well</p> <p>②、更换电动推杆</p> <p>Replace the electrically operated pushe</p> <p>③、更换中心板</p> <p>Replace main PCB</p>
9	<p>座部电机不振动</p> <p>no vibration by the motor in the seat-pad</p>	<p>振动电机坏</p> <p>Print motors failed</p> <p>端子接触不良或是线材坏掉。</p> <p>The terminals and wires are poorly connected or the wires fail</p> <p>中心板坏。Main PCB failed</p>	<p>更换振动电机</p> <p>Replace the print motor</p> <p>将端子接插到位或者更换线材。</p> <p>Plug the terminal well or replace the wires</p> <p>更换中心板</p> <p>Replace main PCB</p>
10	<p>小腿电机不振动</p> <p>no vibration by the motor in the calves-rest</p>	<p>①、振动电机坏。</p> <p>Print motors failed</p> <p>②、端子接触不好或是线材坏掉。</p> <p>The terminals and wires are poorly connected or the wires failed</p> <p>③、中心板坏。Main PCB failed</p>	<p>①、 更换振动电机</p> <p>Replace the print motor</p> <p>②、 将端子接插到位或者更换线材。</p> <p>Plug the terminal well or replace the wires</p> <p>③、更换中心板</p> <p>Replace main PCB</p>
11	<p>座部不充气</p> <p>no gas charging in the seat-pad</p>	<p>①、气泵泄气阀端子接触不良</p> <p>The terminal of the snuffle valves and wires are poorly connected</p> <p>②、泄气阀坏</p>	<p>①、将端子接好</p> <p>Plug the terminal well</p> <p>②、更换泄气阀。</p> <p>Replace the snuffle valves</p> <p>③、更换气泵。</p>

12	小腿不充气 no gas charging in the calves-rest	The snuffle valves fail ③、气泵坏The inflator pump failed	Replace the inflator pump ④、更换中心板 Replace main PCB
13	靠背腰部或肩部不充气 no gas charging in the backrest	④、中心板坏Main PCB fails	

二. 故障检修流程图 Troubleshooting Process

在修理或者替换零配件过程中注意下面几点：

在拆卸连线，移动连接器，或者替换部件前一定要断开电源线插头。

因为半导体（像集成电路，或者其它的）很容易被静电损坏，所以当要触摸PCB前，请确保你的身体和大地有连线（佩带静电手环），或可以将手放在地端，以释放身体上所带的静电。

Notes for repairing chair or replacing parts

A. Make sure the power is off when you tear down the wires, move terminals or replacing parts.

B. The semiconductors(like IC or something else) will easily be damaged by static.

So you touch the PCB before, please make sure your body is connected with the ground.

1、开机无功能/ No function

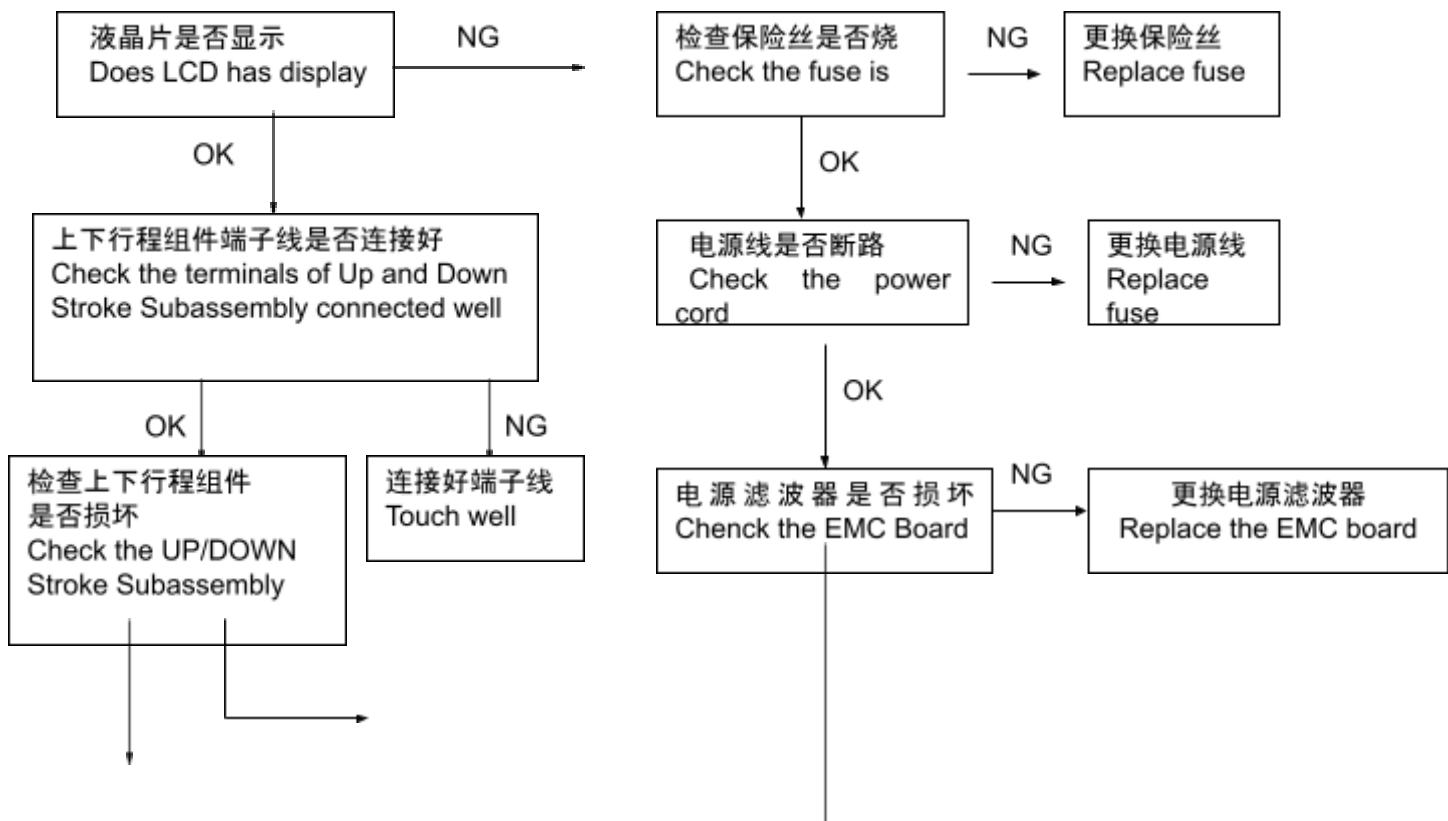

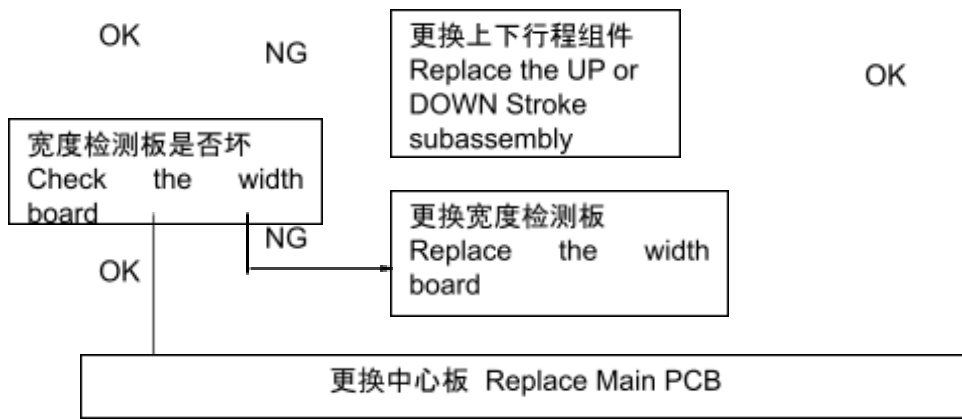

2、机芯宽中窄不能切换 No width switchover

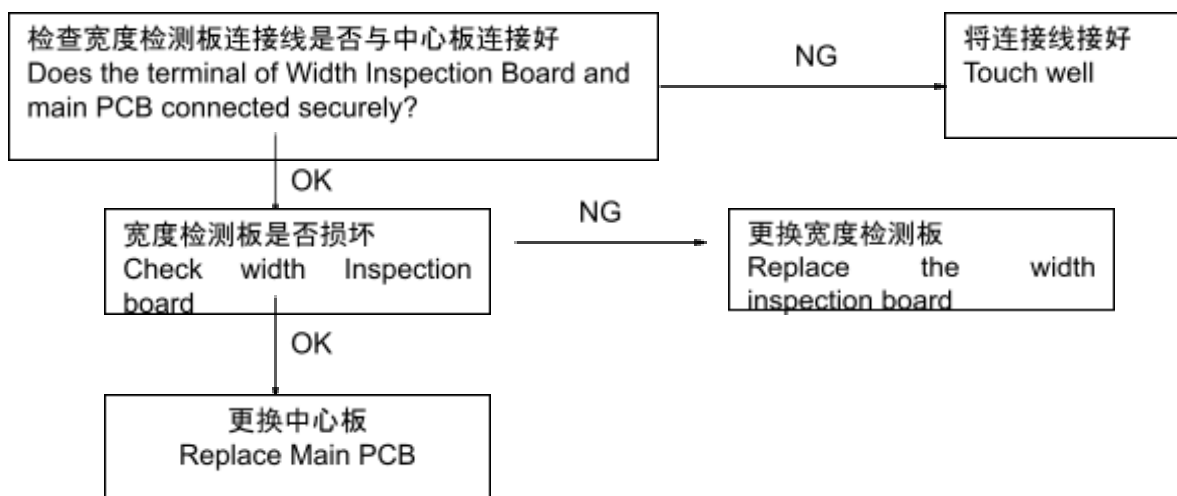

3、不行走/ NO ROLLING

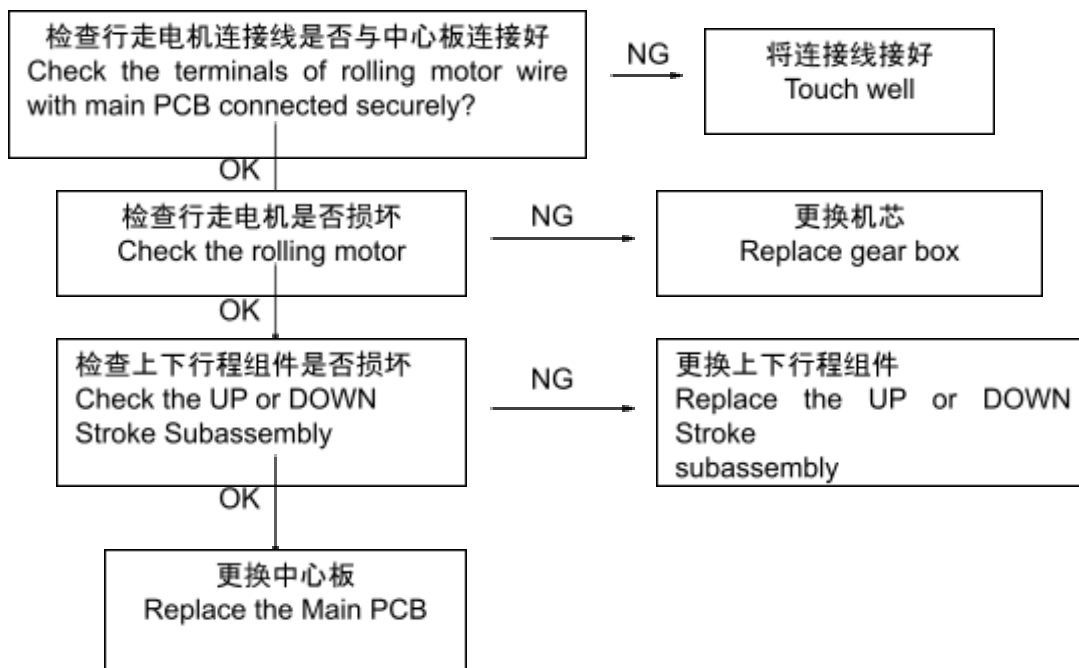

4、不揉捏/ NO KNEADING

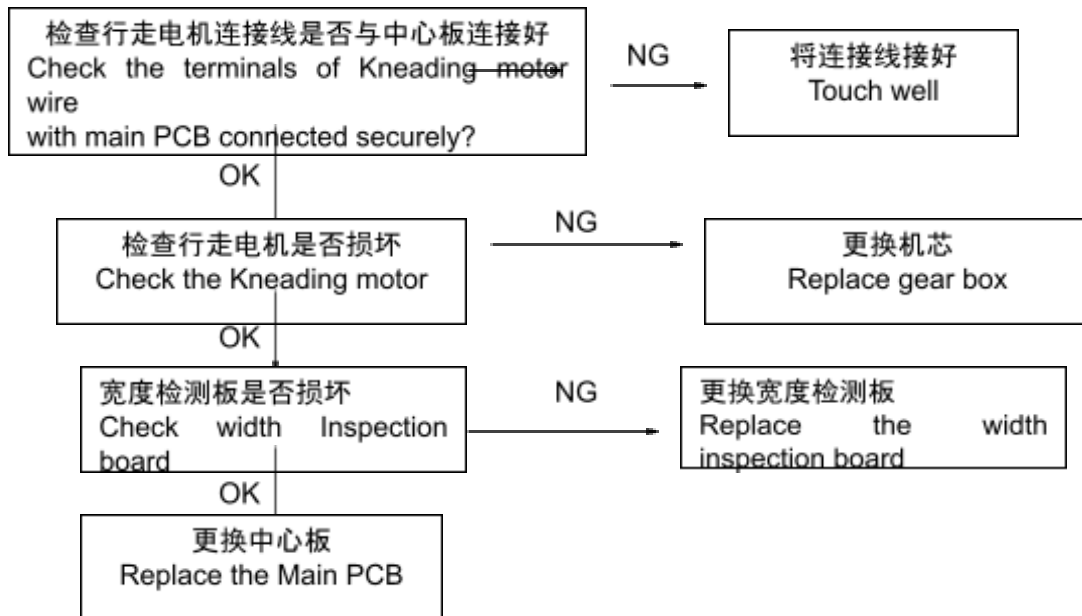

5、不敲击/ NO TAPPING

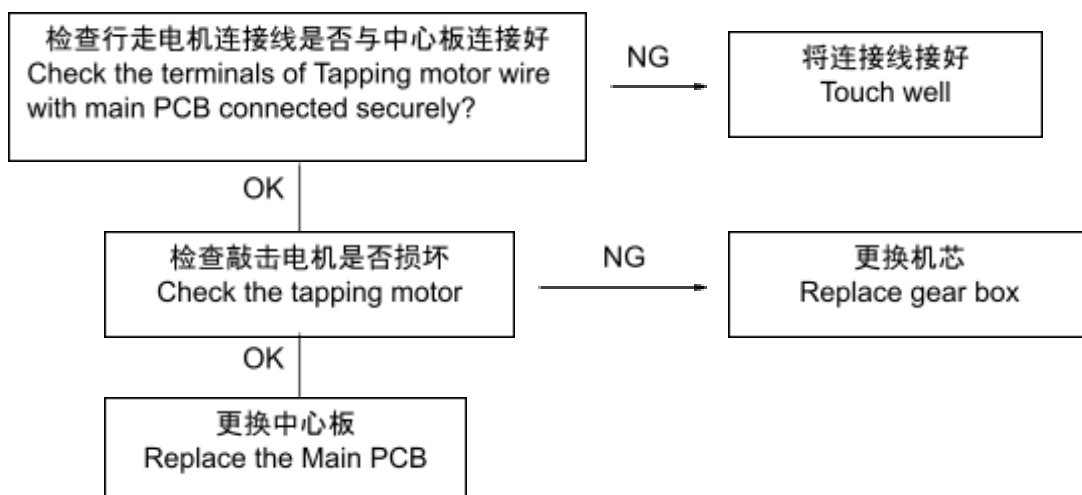

6、手控器上按键无反应

The all buttons of controller aren't response

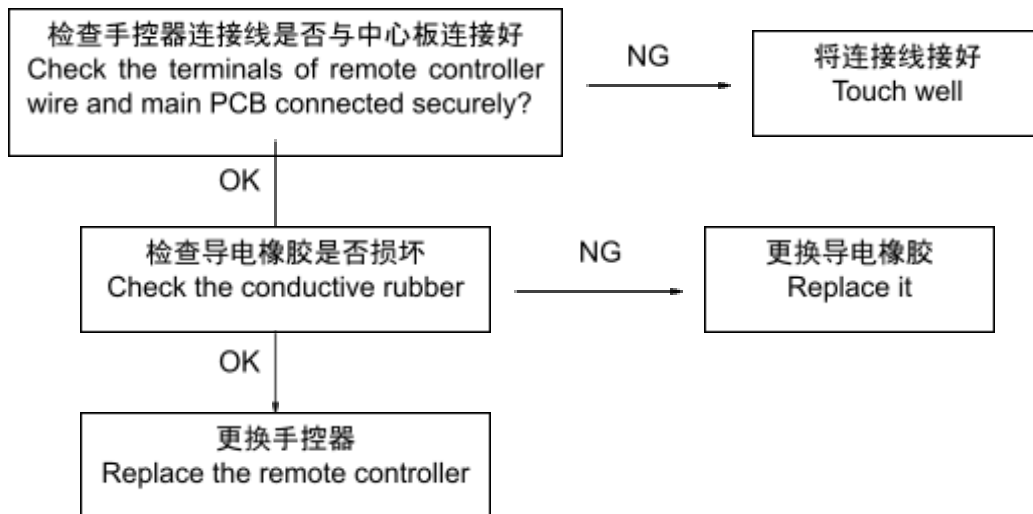

7、电动推杆(靠背/小腿/零重力)不工作

Actuator doesn't work.(Backrest and legrest)

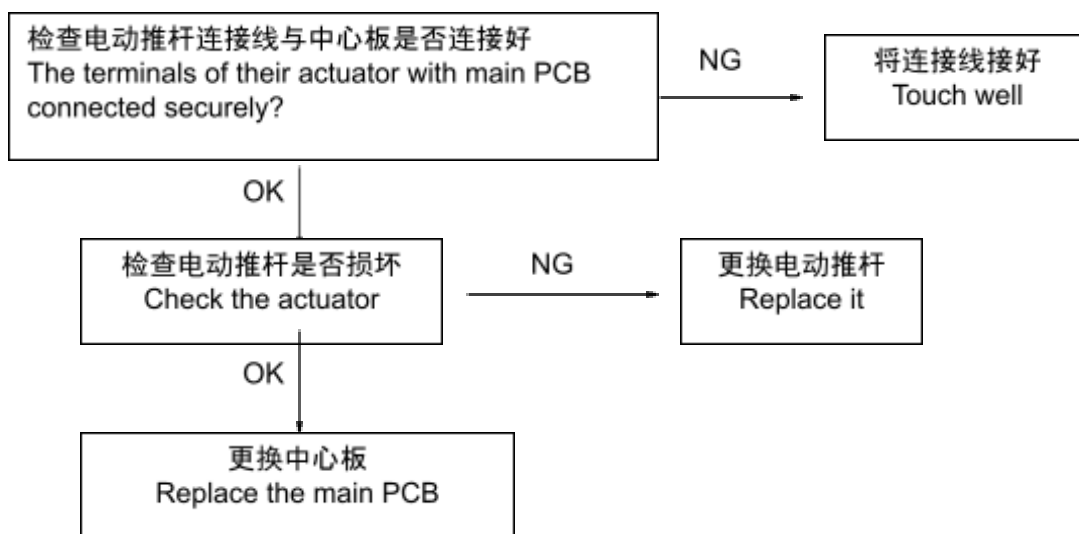

8、座部/腿部/靠背腰部或肩部不充气

No gas charging (Seat pad / Calves-rest/Backrest part)

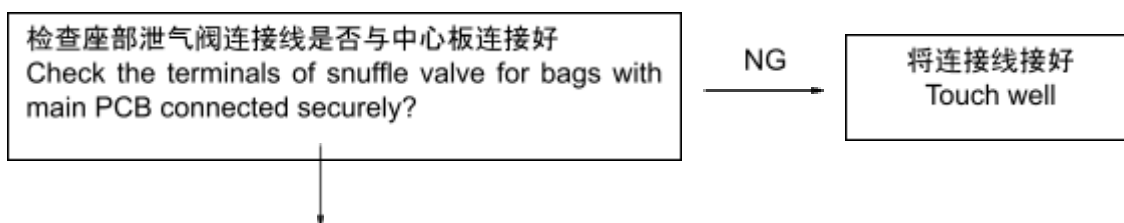

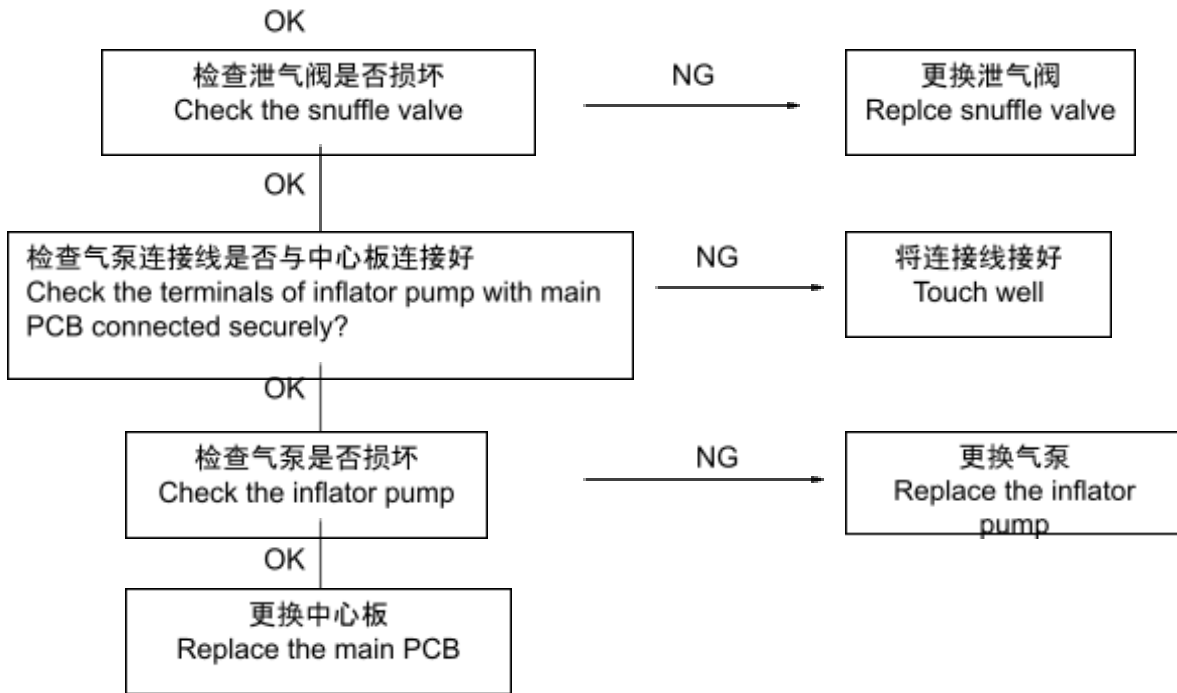

目录

Table of Contents

1.靠背枕头的拆解 Disassembly of the pillow	12
2.披风的拆卸 Disassembly of the backrest pad	12
3.靠背后盖的拆卸 Disassembly of the backrest cover	13
4.机芯组件的更换 Replace the subassembly of gear box	14
5.机芯上下行程光电的拆解 Replacing up & down limit sensor.	19
6.手控器的更换 Change the remote controller	21
7.侧板的拆卸 Disassembly of the side board	21

8.更换靠背&小腿电动推杆 Replace the backrest 、 seat-rest actuator	23
9.更换中心板 Replace The Main PCB.	25
10.更换充气泵 replace inflant pump	27
11.更换变压器 replace the transformer	28
12.更换泄气阀 replace the air valve	28
13.小腿的内部分解 Disassembly the leg rest and internal structur	29

1.靠背枕头的拆解 **Disassembly of the pillow**

The chair have two pillows

A. 拉开粘扣, 即可取下小枕头

Pull up the thread gluing,very easy take down



Small pillow

B.大枕头也是一样的取法

The same way of A



Big pillow

2. 披风的拆卸 **Disassembly of the backrest pad**

A. 拉开披风与靠背的拉链

Unzip zippers of the pad,

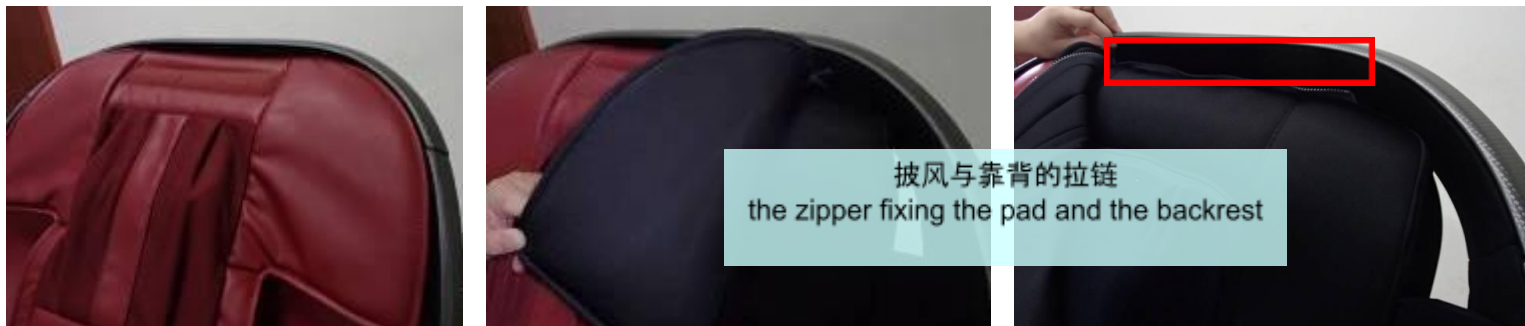

B. 拉开座部与左右座侧的连接拉练

OPEN zipper on the seat and between of seat side



C. 拉开座部与腿部之间的拉练,之后再拉开内部缓冲垫的连接,即可以取下披风了

OPEN zipper on the seat and between of leg, then open zipper with the backrest pad

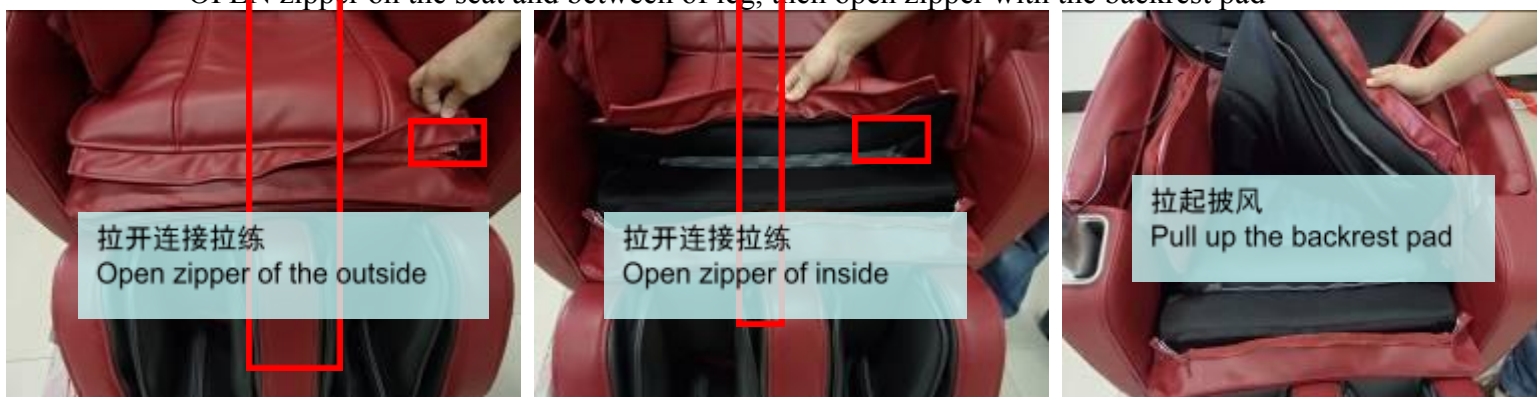

NEXT:



披风组件
Backrest pad

3. 靠背后盖的拆卸 **Disassembly of the backrest cover**

A. 找个靠背后盖的4枚螺丝位置,然后拆下它们即可以取下后盖了

Slack and remove the 4 screws of the rear cover, then you can take down it



4. 机芯组件的更换 **Replace the subassembly of gear box**

A. 参考步骤3拆开后盖

Refer NO.3 disassembly of the backrest cover

B. 开机后让机芯停在顶部

Power on ,let the gear box stop at the top of backrest

C. 然后拆除机芯上的引线

Then Disconnect the wire at the gear box.

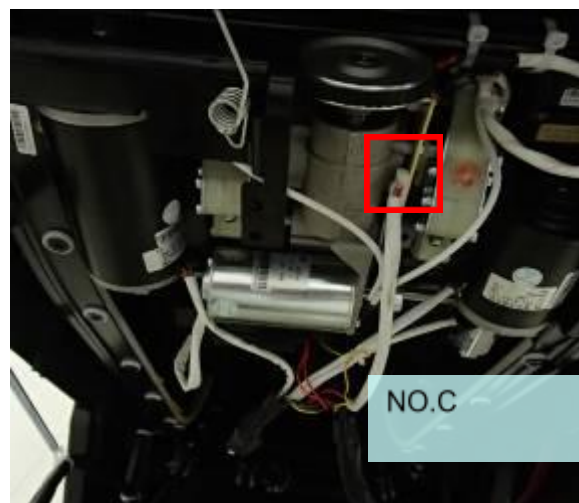
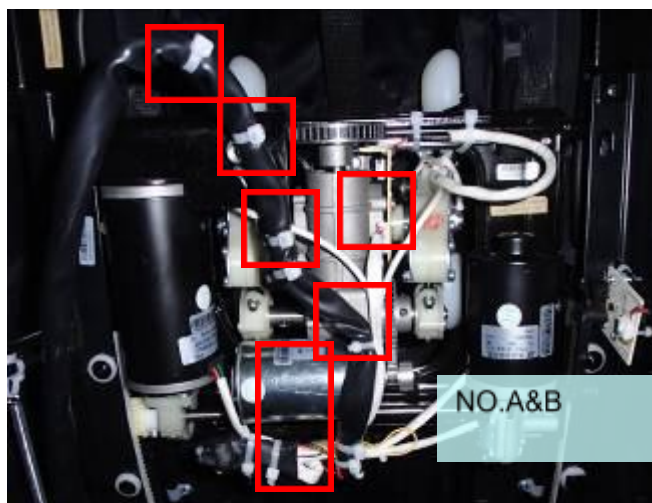

NEXT:

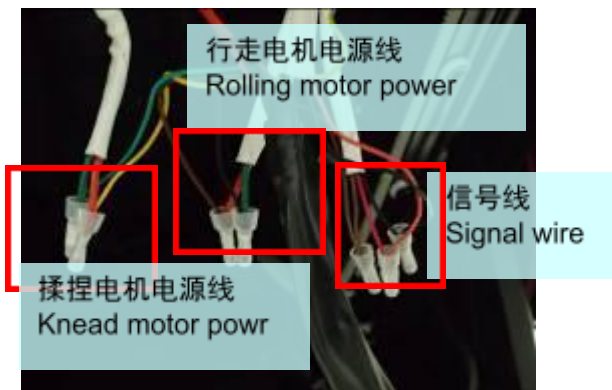

NEXT:

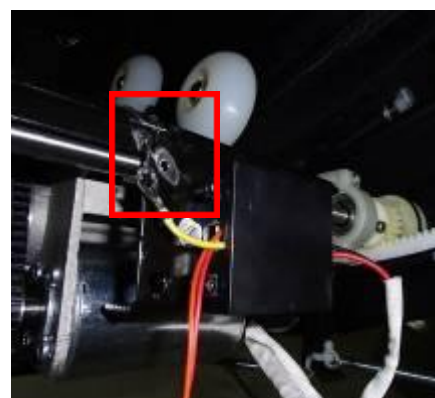
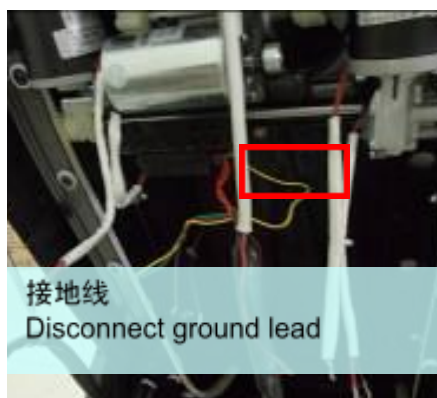

NEXT:

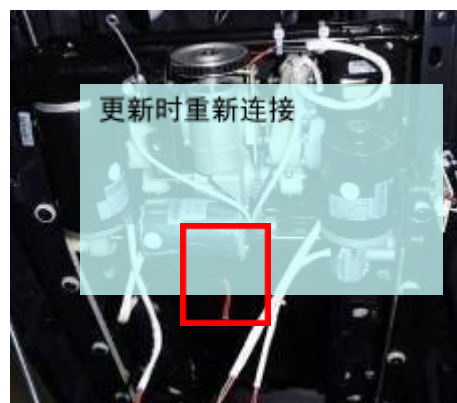
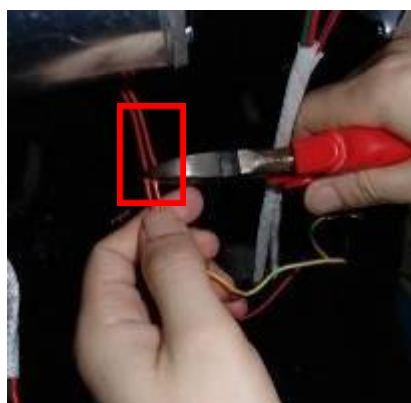

C. 打开机芯出行缺口,然后取下机芯防撞块

Open the gear box way out at backrest top, then take down the Movement collision block

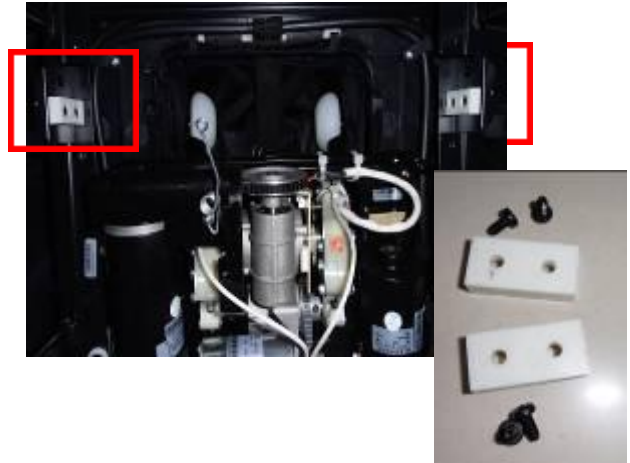
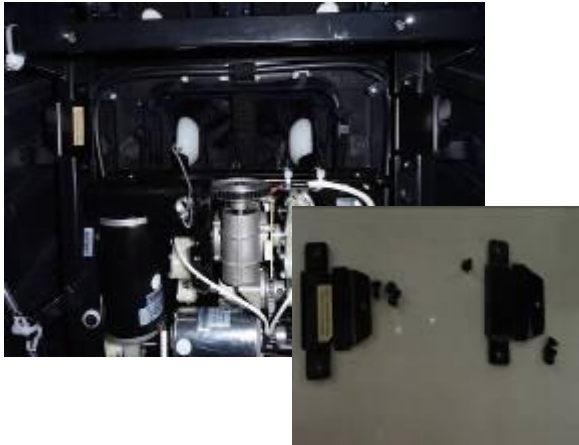

D. 给行走电机加入直流12~24V电源,让机芯向上推动并取出它
 DC12~24V IN to the rolling motor , then move out the gear box

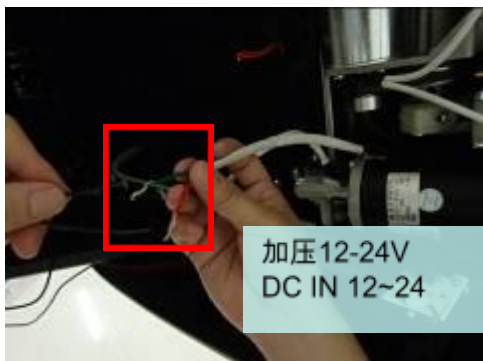

加压12-24V
 DC IN 12~24



取下行走轮子
 Take down tow wheel

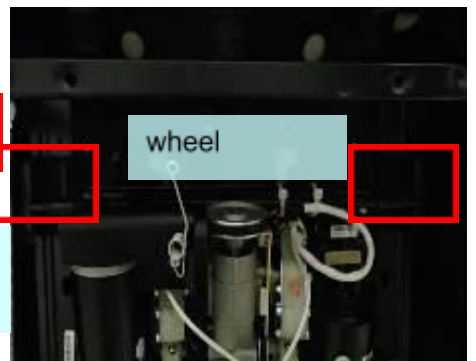

NEXT:



如图所示,压下机芯,放平,之后再加电源向上行走即可
 As picture shown,screw down gear box,then DC in 12~24 to rolling moto and take out it



NEXT:

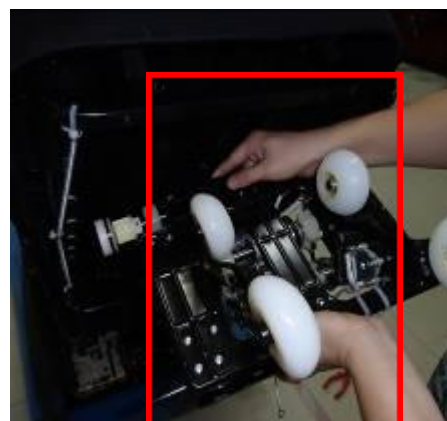



Rolling out

Gear box

E. 机芯图解
Gear box

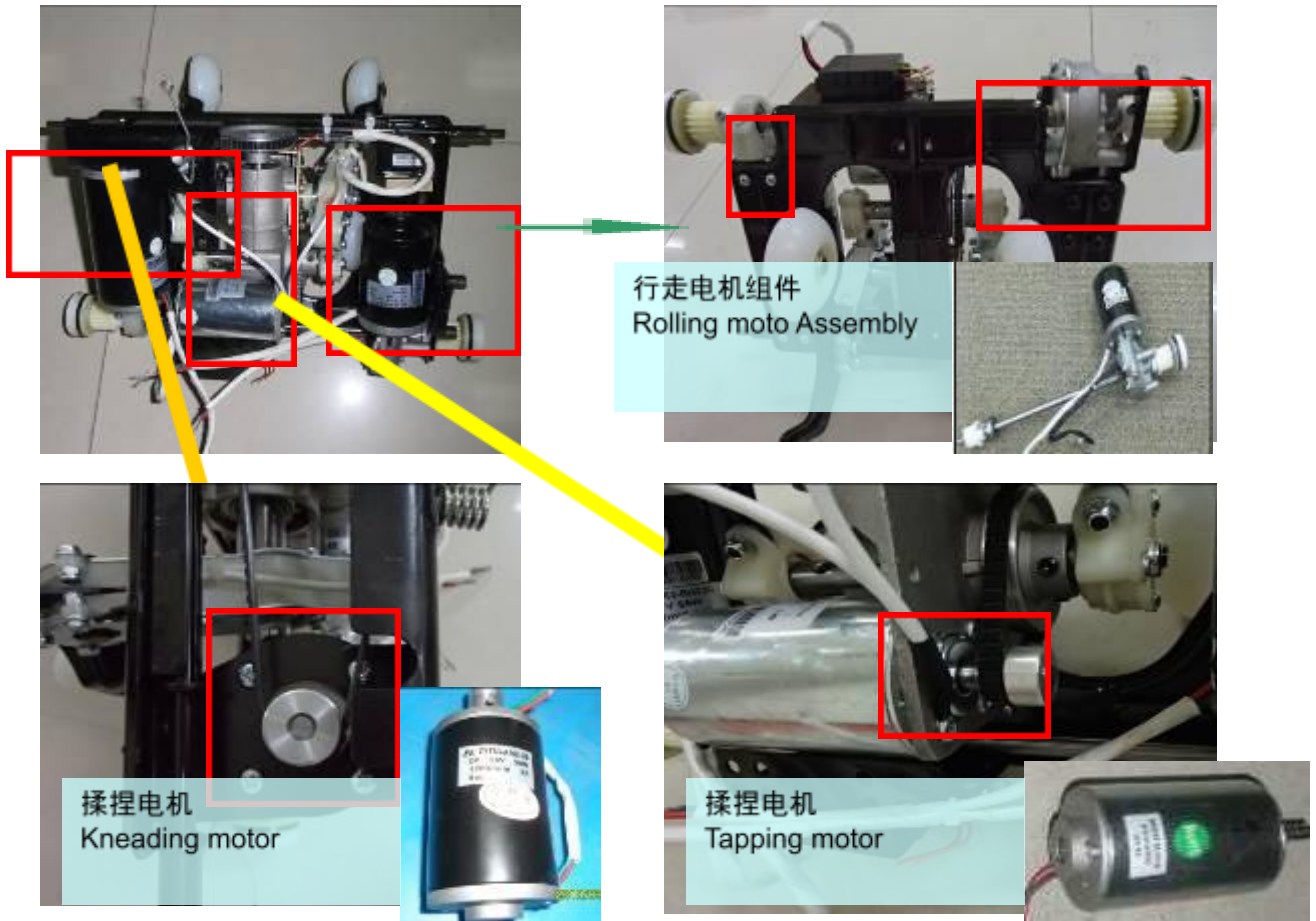

F. 机芯组件
Gear box assy

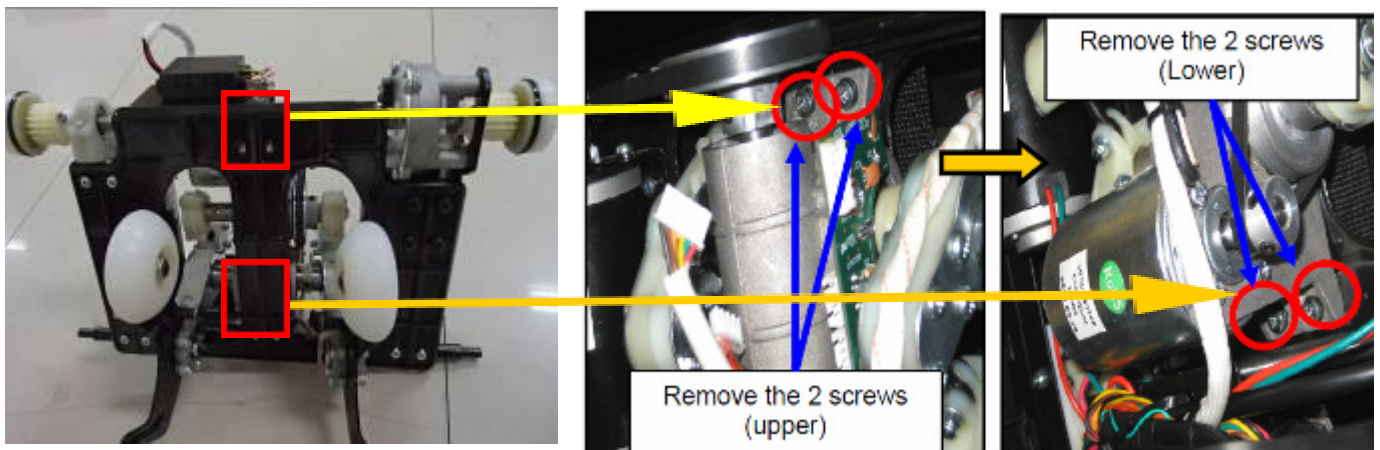

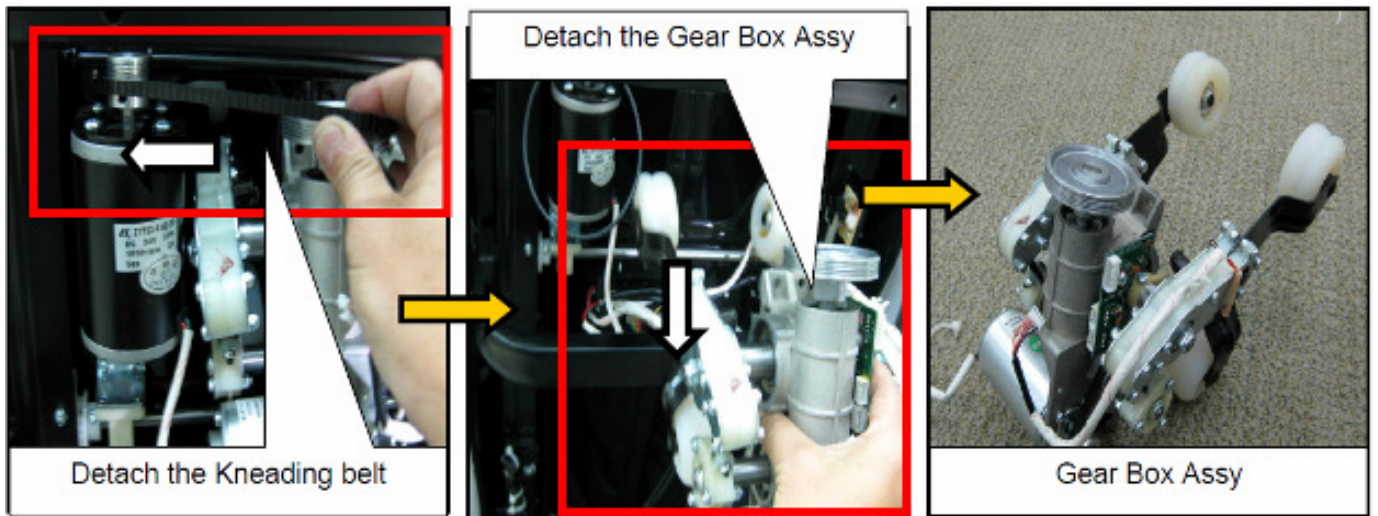

5. 机芯上下行程光电的拆解 Replacing up & down limit sensor.

打开背架后盖后,我们可以看到上下行程光电

we can find up & down limit sensor

A. 打开后盖参考步骤3, Ref no.3: Disassembly of the backrest cover



B. 上行程光电的拆解比较简单,如图所示

Disassembly the up limit sensor is very easy(As shown picture)



首先让机芯向下移动,给拆解上行程光电让出空间
First. Moving gear box down get space to limit sensor

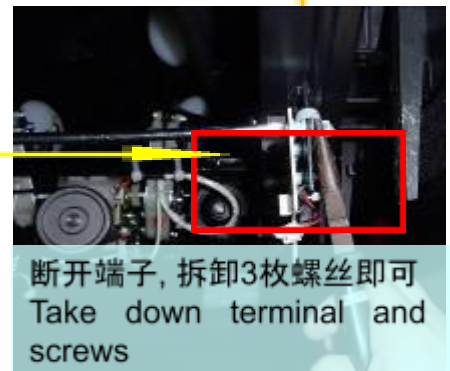
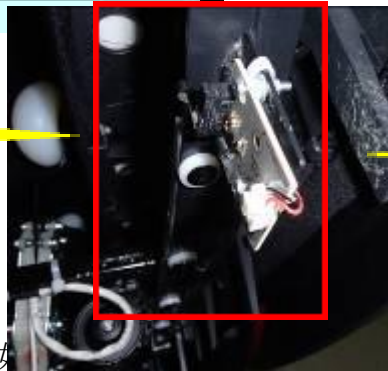
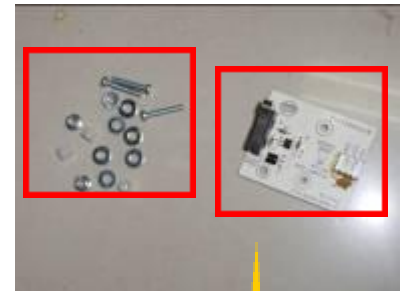

断开端子,拆卸3枚螺丝即可
Take down terminal and 3 screws

Disassembly the down limit sensor is difficulty(As shown picture)



为了更方便的拆解下行程光电,我们把拉绒布拉开
After open lint to disassembly down sensor better easy



NEXT.



下行程光电的位置
Location the sensor



拆解3枚固定螺丝及端子
Loose the 3 screws

6. 手控器的更换 Change the remote controller



在背架后下方可以看到如图装置, 只需拆下R形夹及逆时针旋转对接头固定装置就可取下手控器了
Take down the screw and Rotating Joint only

7. 侧板的拆卸(以左侧为例,右侧同理)

of the side board(As an example, on the left side of the right side in the same way)

Disassembly

A. 从侧板底部用手握住慢慢掀起就可以拿下饰板,
Slowly By hand pull up at bottom , then take down plaque

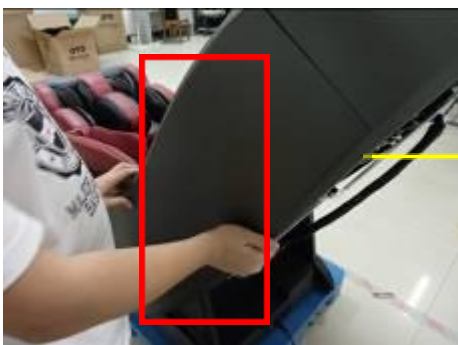
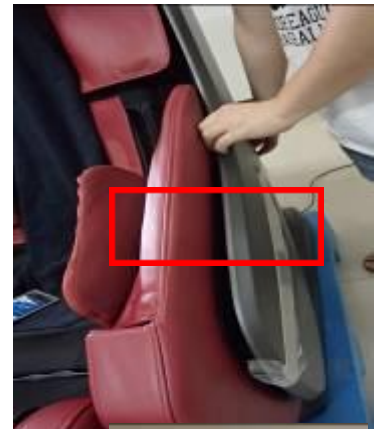

B. 拆解侧板 Disassembly the side panel

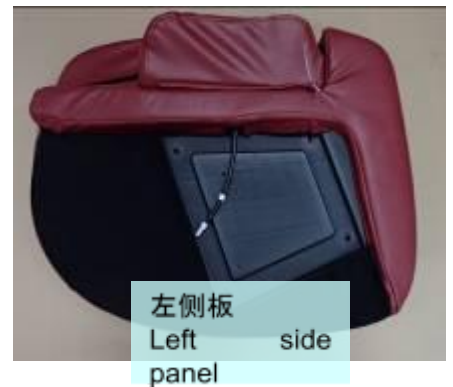

拆解内装饰板 Disassembly the internal plaque

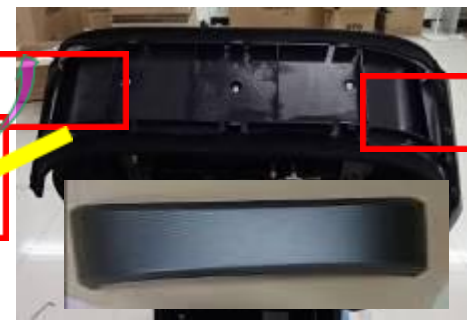
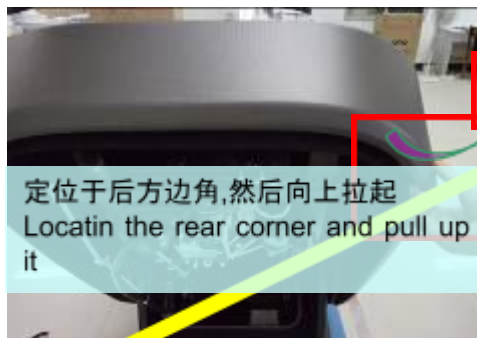
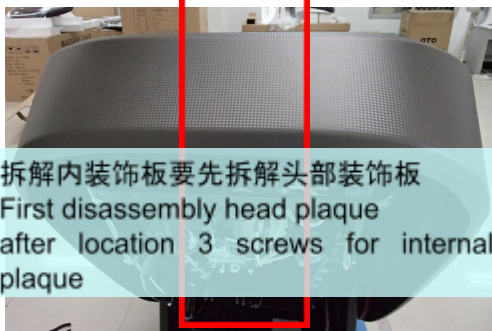

NEXT:



A: 取下后档布,可以看到靠背电动推杆后方固定位置
After take the rear bumper cloth, you can see the backrest actuator



个固定螺丝
and screw 2 screws

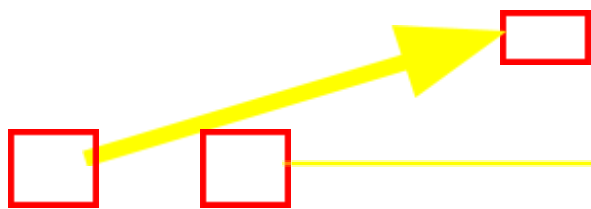

NEXT:



拆除2个固定螺丝
Loose and screw 2 screws

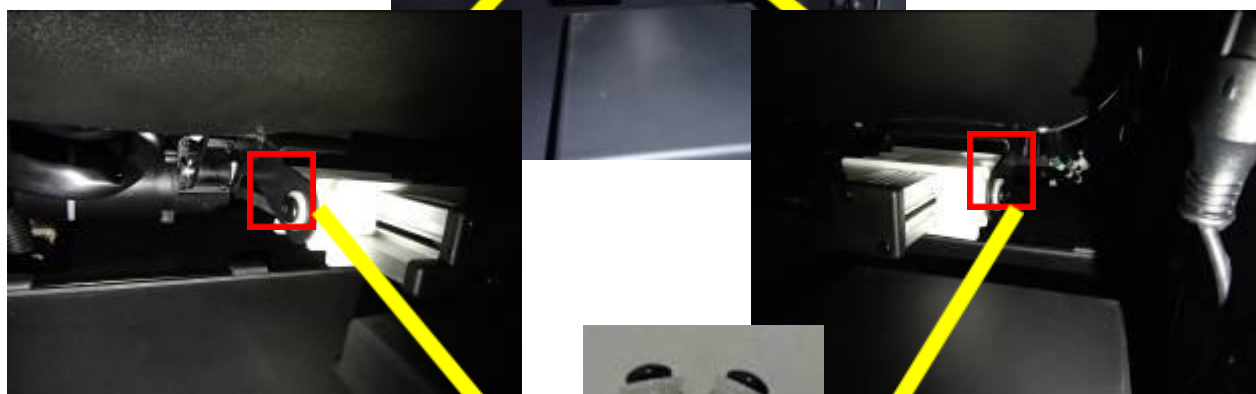

拆除之后
After take down screws

B:抬起小腿可以看到下前挡
After pull up the legrest
取下电动推杆的波浪形卡口销及销轴, 为电动推杆端子。
Take away the pin and disconnect wire terminal of a actuator



拆下下前挡板
Moving the plate washer

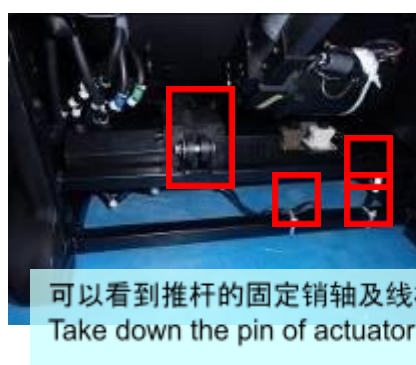

可以看到推杆的固定销轴及线材固定点及接头
Take down the pin of actuator and open the wire terminal



NEXT:

After moving out the backrest actuator it



Backrest actuator

C. 小腿电动推杆的更换

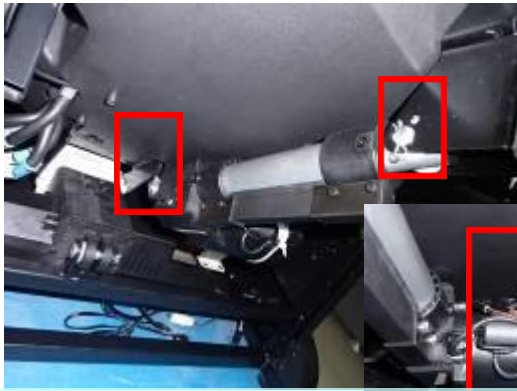

抬起小腿拆下前挡板,之后定位图中三个位置,取下它们即可(建议先拆上方销轴以方便拆底部销轴)
Pull-up the legrest and disassembly the plate washer then location map of three position, (moving the top of pin first) NEXT

取下电动推杆的波浪形卡口销及销轴,分离电动推杆端子.

Take away the two pins and disconnect wire terminal of a actuator



9. 更换主板 Replace The Main PCB

A. 用十字螺丝刀取下固定中心盒上前盖的3个十字盘头螺钉,就可以取下上前盖

Slacken and remove fixing the 3 screws in the PCB box.

Then you can remove the front cover away



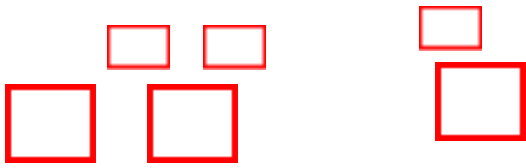

中心盒上前盖上的3枚螺丝
the 3 screws fixing front upper cover for PCB box



NEXT



定位图中三个位置, 除去它们即可
disassembly the plate washer then location map of position, minimal then take way out the PCB BOX

Disconnect all

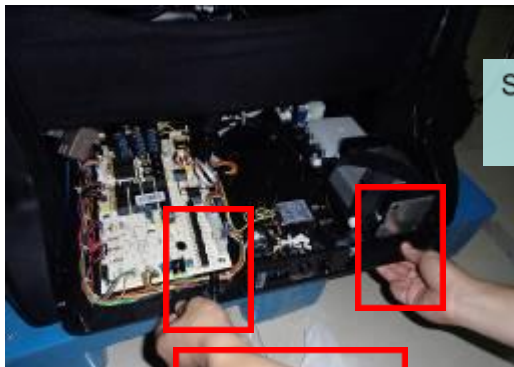

Step 1: 拉出中心盒
Take out PCB Box

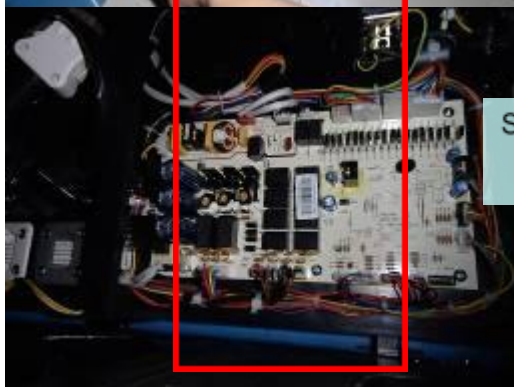
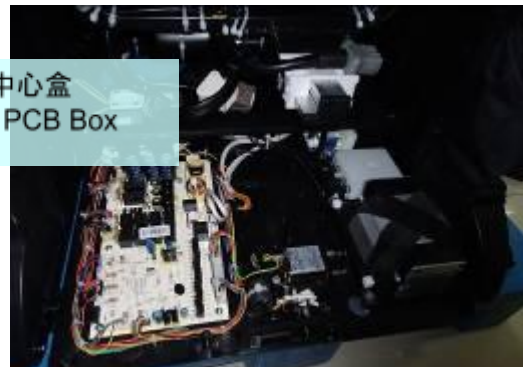

Step 2: 定位中心板
Location the PCB

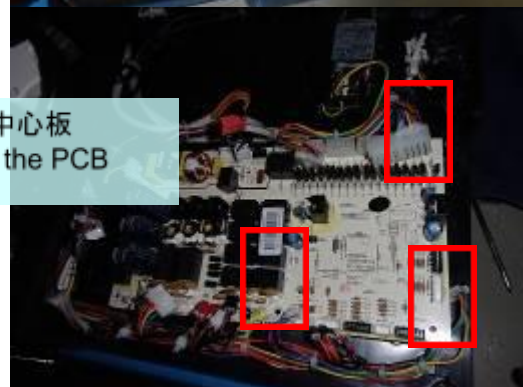

3: 取下中心板
Take out the P



10.更换充气泵 **replace inflant pump**

参考NO.9 拆开中心盒, 然后定位充气泵

Refer NO.9 replace pcb to open the pcb box and location at inflant pump

A. 取下中心盒上前盖。

Take down the front cover of main PCB box

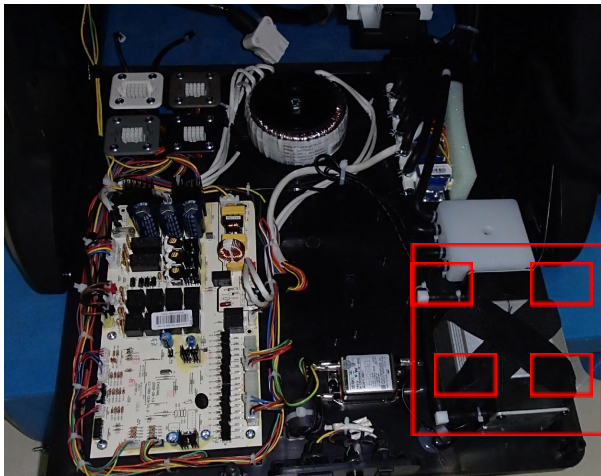

取下固定充气泵的四枚螺丝
Slack and remove the 4 screws

B. 用工具拔出充气泵底部的橡皮堵头

Pull out the rubber poles fixing the inflator pump on the base plate with nipper pliers.



拔出塑胶堵头
Pull out the rubber poles

C. 断开充气泵的接线端子

Disconnect the terminal of the inflator pump, then cut the cable ties fixing the wires.

D. 拔开充气泵的气管接头

Pull out the gas hose connecting the inflator and snuffle valves. Then the whole pump can be removed.

E. 逆序换上新的充气泵

Proceed in the reverse order of the disassembly when replacing a new one.

注意Attention: 装回充气泵时, 要将橡胶堵头放到中心盒底盘的孔内, 并用尖嘴钳从下面拉出, 确保充气泵已经固定住When fixing the pump, you should insert the rubber poles into the hole of the base plate, then pull them though with nipper pliers, then the rubber poles are locked in the hole.

11. 变压器的更换 **replace the transformer**

参考NO.9 拆开中心盒, 然后定位变压器

Refer NO.9 replace pcb to open the pcb box and location at transformer

A. 取下中心盒上前盖。

Take down the front cover of main PCB box

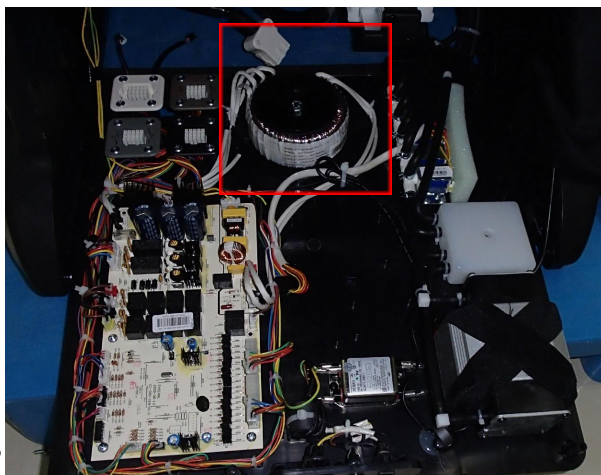

线端子



变压器的螺丝 the screw fixing the transformer

B. Slack the screw fixing the transformer, then disconnect all the terminal of transformer, replace a new one

12. 泄气阀的更换 **replace the air valve**

参考NO.9 拆开中心盒, 然后定位泄气阀

Refer NO.9 replace pcb to open the pcb box and location at air valve

A. 取下中心盒上后盖

Take down the inner cover of main PCB box

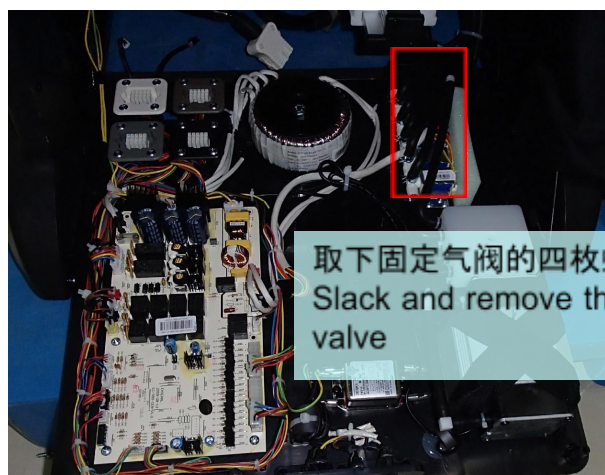

取下固定气阀的四枚螺丝, 拔掉接线端子, 可以更换气阀

Slack and remove the 4 screws, disconnect the terminal of the air valve

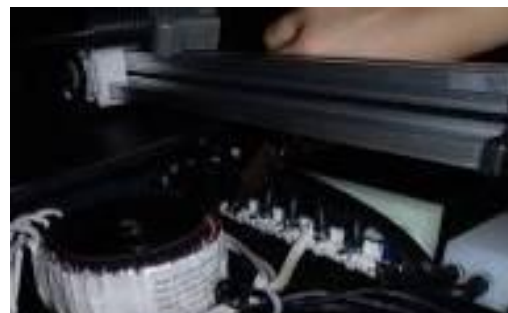



13. 小腿的拆卸及内部结构

Disassembly the leg rest and internal structure

A. 拉开座部与腿部之间的拉练, 拆下固定小腿与座部之间的连接销轴

OPEN zipper on the seat and between of legrest, then find the two pin fix on the seat and legrest

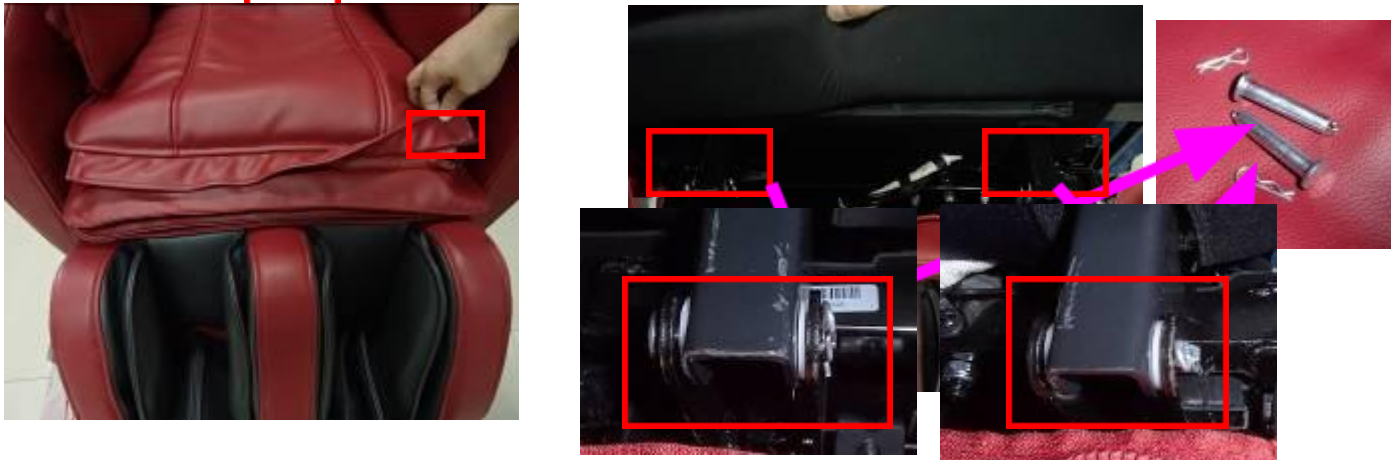

B. 完成A步骤之后, 断开小腿的数据线及气管及小腿推杆的连接销轴即可以分离小腿组件

After step A, disconnect the data link wire and air hose , the take down the pin at the legrest actuator



NEXT:

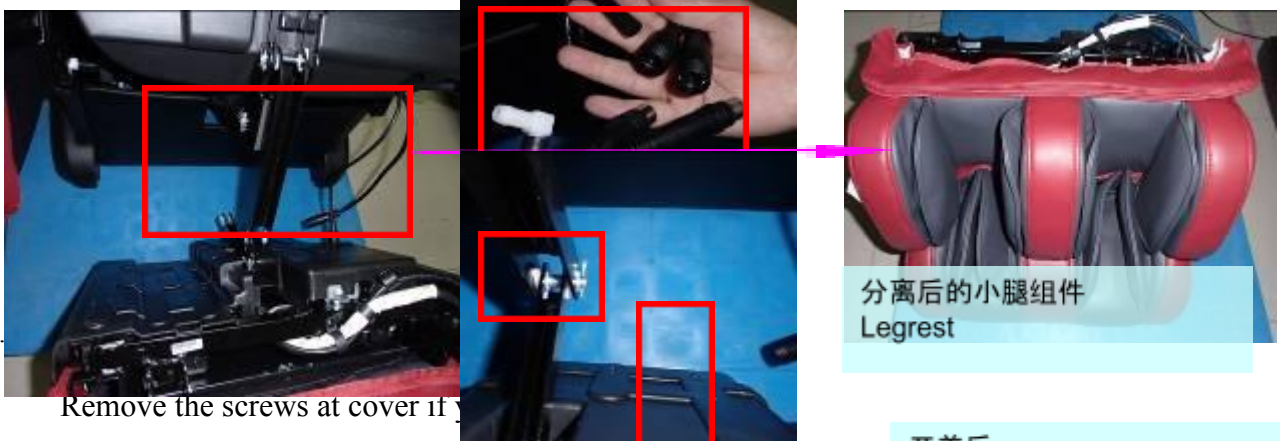

C.

Remove the screws at cover if



2. 拆解小腿伸缩推杆组件

Disassembly the rolling motor subassembly

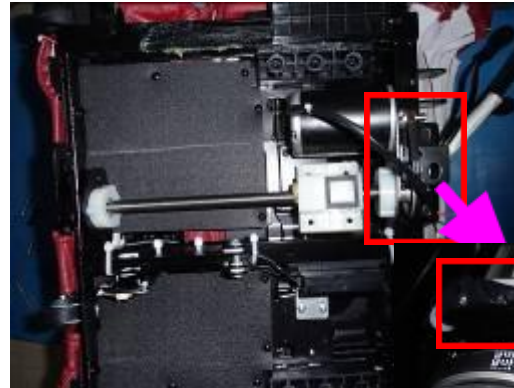
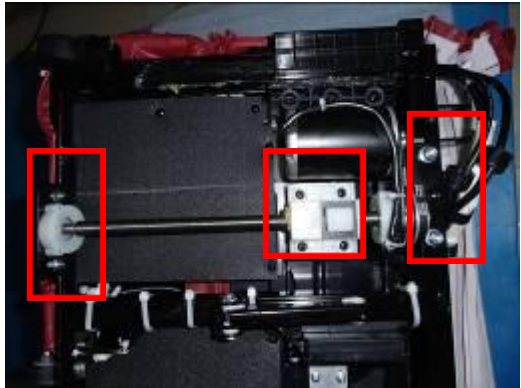

3颗固定螺丝
Disconnect wire and screws

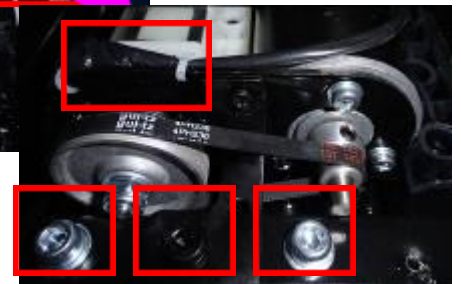

NEXT:



伸缩电机组件
Rolling motor subassembly



假如只需更换电机, 只需断开线材, 松开此图三颗固定螺丝即可
IF Disassembly the motor only
Disconnect wire and screws 3PCS



3. 上下腿部组件的拆卸

Leg rest walk assembly

先拆下脚轮, 拆卸方法如图所示

Disassembly the truckle see picture below



定位两个脚垫, 只需拆下螺丝即可
Location 2 food pad of the legrest



往Open 方向转动, 即可拿下盖子
Turn run "open" direction to take down cover

NEXT:

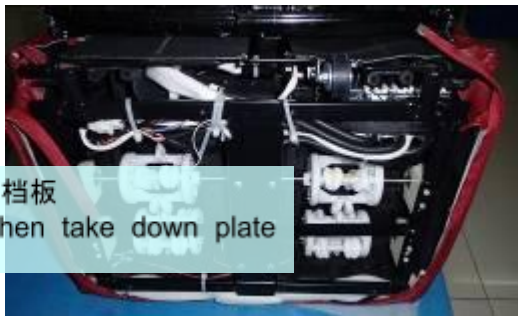

拉开拉练, 然后拆下档板
Open the zipper then take down plate washer

NEXT



下小腿共有6枚固定螺丝
Remove the 6pcs screws of Feetrest



另一侧也有一个
Attention other side

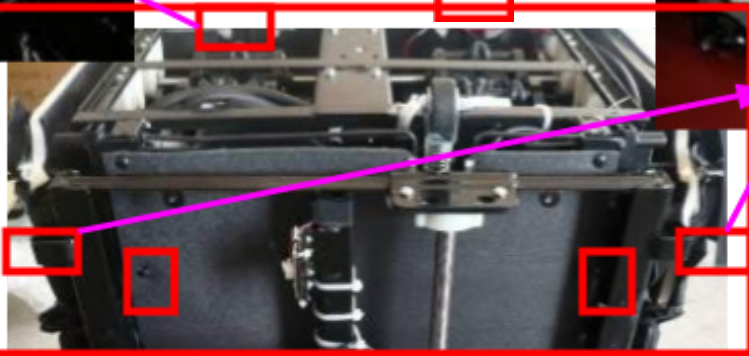

4枚固定螺丝
Attention 4PCS screws

分离上下小腿皮
After remove the
移除这些螺丝后
Remove the these

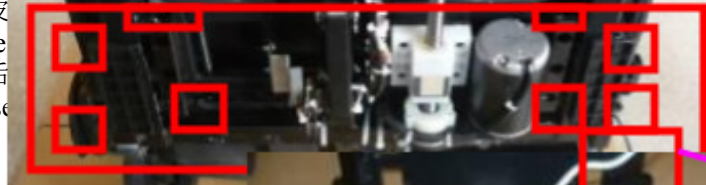

每个侧边有2枚固定螺丝
Attention other side



螺丝
screws of

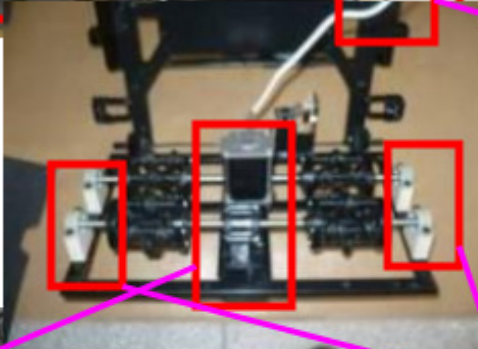

4枚固定螺丝
Attention 4PCS screws

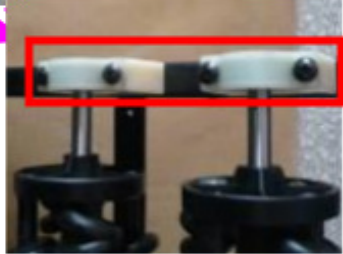

两侧共8枚固定螺丝
Attention 8PCS screws of two sides