

# Apex duo 5D+4D

## Service Manual



# Contents

<b>I . Components of the product :</b> .....	1
1. RK9501 Structure Diagram .....	1
2. Introduction to Key Components . . . . .	3
<b>II. Common Faults and Troubleshooting Methods</b> . . . . .	5
1. Massage chair inoperative; remote controller no display. . . . .	8
2. Massage mech and strut inoperative; other functions normal; remote controller displays. . . . .	8
3. Upper mech with abnormal lifting . . . . .	9
4. Upper mech with abnormal kneading . . . . .	10
5. Upper mech with abnormal tapping . . . . .	11
6. Upper mech with abnormal tilting forward . . . . .	12
7. Lower mech with abnormal lifting . . . . .	13
8. Lower mech with abnormal kneading . . . . .	14
9. Lower mech with abnormal tapping . . . . .	14
10. Lower mech with abnormal tilting forward . . . . .	15
11. Whole machine or a circuit not inflating. . . . .	16
12. Back strut with abnormal operation. . . . .	17
13. Leg strut with abnormal operation. . . . .	17
14. Foot roller inoperative. . . . .	18
15. Leg rubbing motor inoperative. . . . .	18
16. Telescoping motor with abnormal operation. . . . .	18
17. Leg heating cloth inoperative. . . . .	19

18. Foot heating cloth inoperative. . . . .	20
19. Waist heating cloth inoperative. . . . .	20
20. Health Test function with abnormal operation. . . . .	21
21. Speaker not working, voice control abnormal. . . . .	21
22. Anion not working. . . . .	21
23. Aromatherapy not working. . . . .	22
24. Abnormal charging. . . . .	22
25. Massage mech heating abnormal. . . . .	23
26. LED light strip abnormal. . . . .	23
27. Armrest door-closing signal abnormal. . . . .	24
28. Tablet control abnormal. . . . .	24
III. Mechanical failures and solutions: . . . . .	25
1. Repair the massage machine. . . . .	25
2. Dismantle the armrest assembly and shoulder part. . . . .	26
3. Dismantle the front backrest plastic body assembly. . . . .	35
4. Dismantle the power box assembly. . . . .	36
5. Dismantle the leg and foot part. . . . .	36
6. Dismantle the backrest strut and leg-foot strut assembly. . . . .	41
7. Dismantle the backrest frame solenoid valve assembly. . . . .	43
8. Adjust the gap between the armrest assembly and the shoulder part. . . . .	45
9. Repair the massage mech assembly. . . . .	49
10. Replace the air pump assembly. . . . .	49

IV. System connection diagram . . . . . 51

# I、 Components of the product:

## 1. RK9501 Structure Diagram

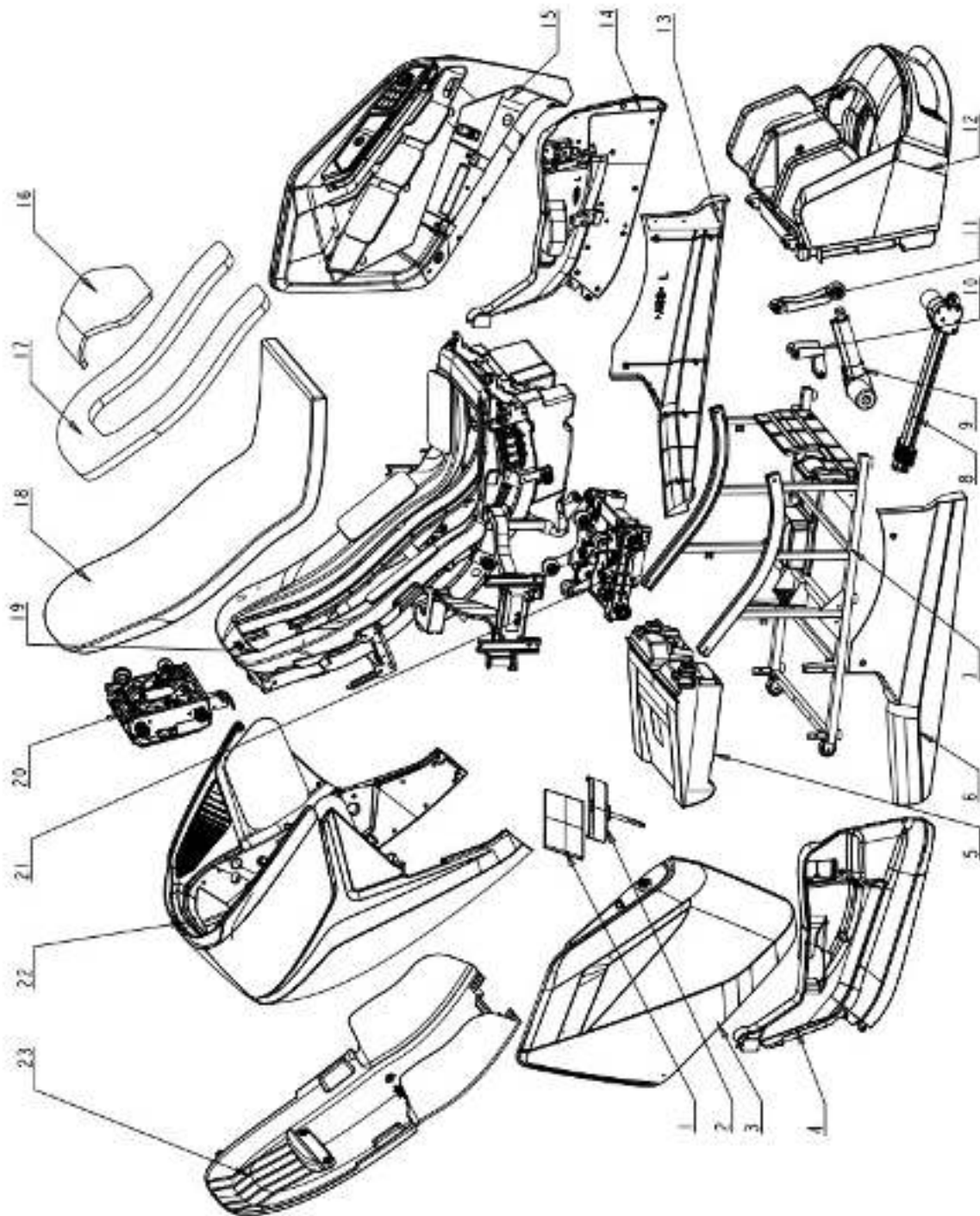

## Mechanical Components List

NO	NAME	PIECE	NO	NAME	PIECE
1	CMD Tablet Controller	1	22	Shoulder cushion	1
2	Tablet Bracket Assy	1	23	Backrest Cover	1
3	Right Armrest Assy	1			
4	Right Lower Guard Assembly	1			
5	Power Box Assy	1			
6	Right Fender	1			
7	Seat Frame Assembly	1			
8	Seat Actuator	1			
9	Leg and Foot Electric Support Rod	1			
10	Actuator Split Ear Seat Component	1			
11	Legrest Actuator	1			
12	Leg and Foot Assembly	1			
13	Left Fender	1			
14	Left Lower Guard Assembly	1			
15	Left armrest assembly	1			
16	Pillow Assembly	1			
17	Shawl Assembly	1			
18	Back Seat Cushion	1			
19	Back-rest Assy	1			
20	Upper Mech	1			
21	Lower Mech	1			

## 2. Introduction to Key Components



MAIN PCB

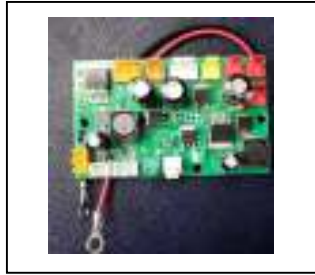

24V Voltage Adapter Board Assembly



Switching Power Supply



Filter



Filter Board



Upper Mech



Lower Mech



Leg Strut



Back Strut



Three-in-One Switch



Air Pump

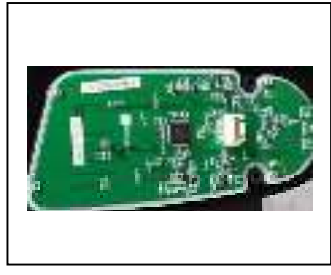

Simple Handheld Control Panel



Voice Board



Upper Mech Board



Lower Mech Board



Roller Assembly



Aromatherapy Fan

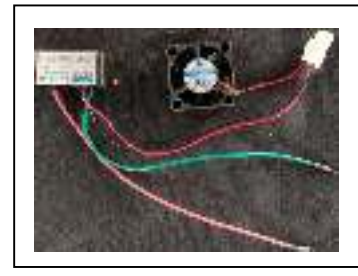

Anion

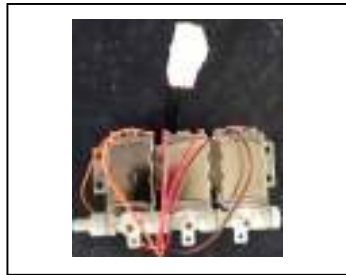

Seat Solenoid Valve



Power Box Assembly

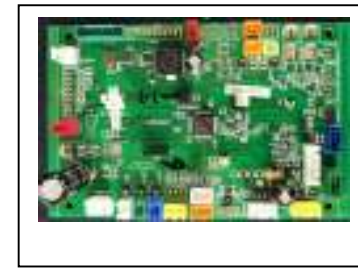

Right Armrest Panel Assembly



Left Armrest Panel Assembly



Wireless Charging Module



Fast Charging Module



Foot and Leg Panel



Health Test Module



Speaker



Shoulder Light Strip



Armrest Logo Light Strip



Armrest Lower Light

## Common Faults and Troubleshooting Methods

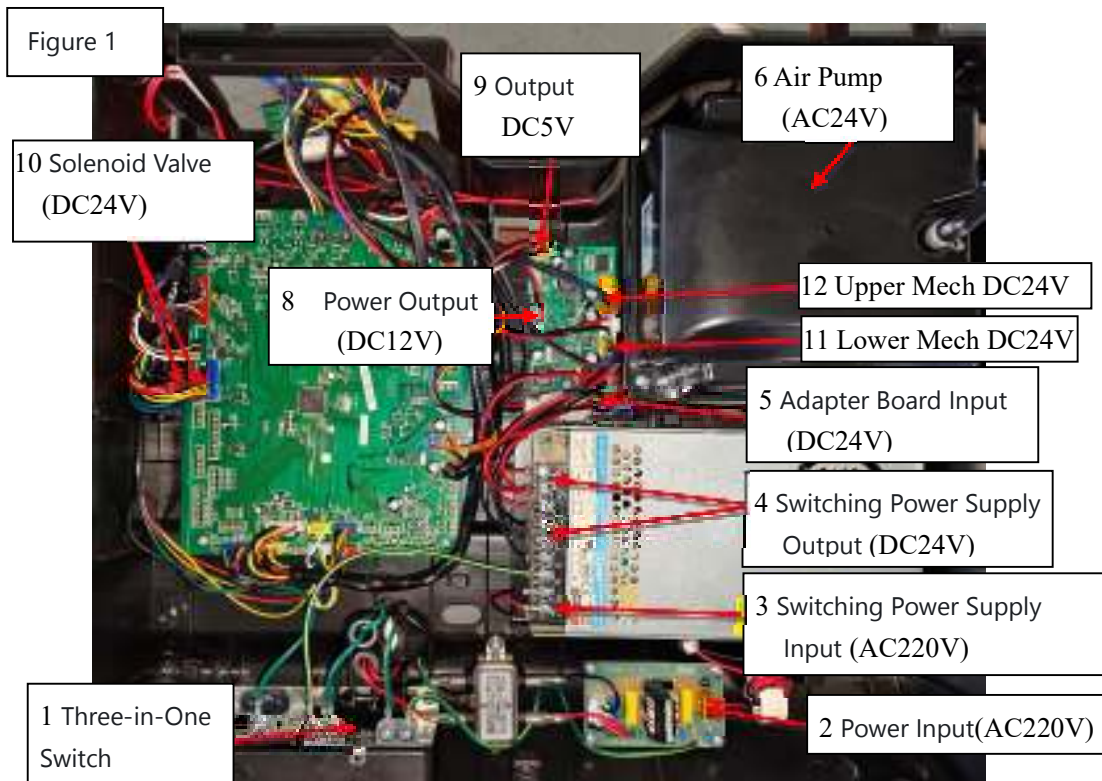

Electrical connection diagram

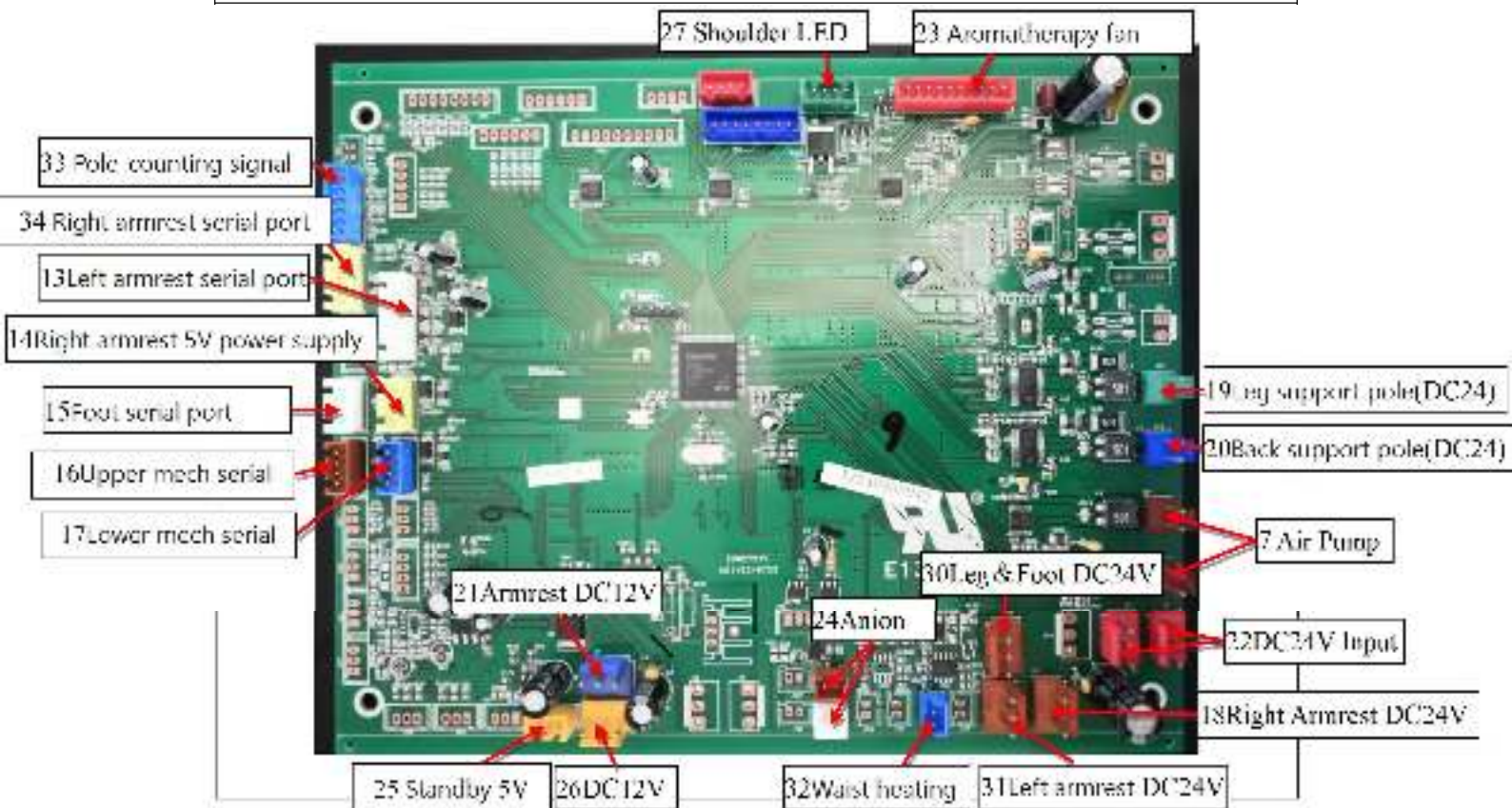

## 24V Voltage Converter Board Electrical Connection Diagram

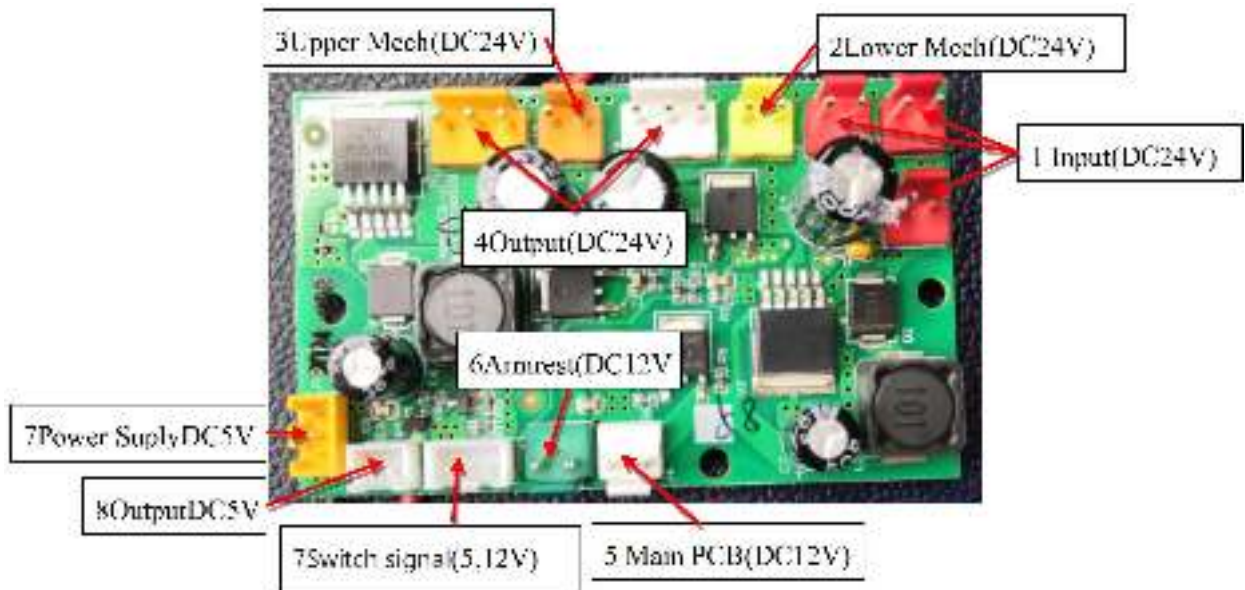

## Upper and Lower Mech Circuit Board Electrical Connection Diagram

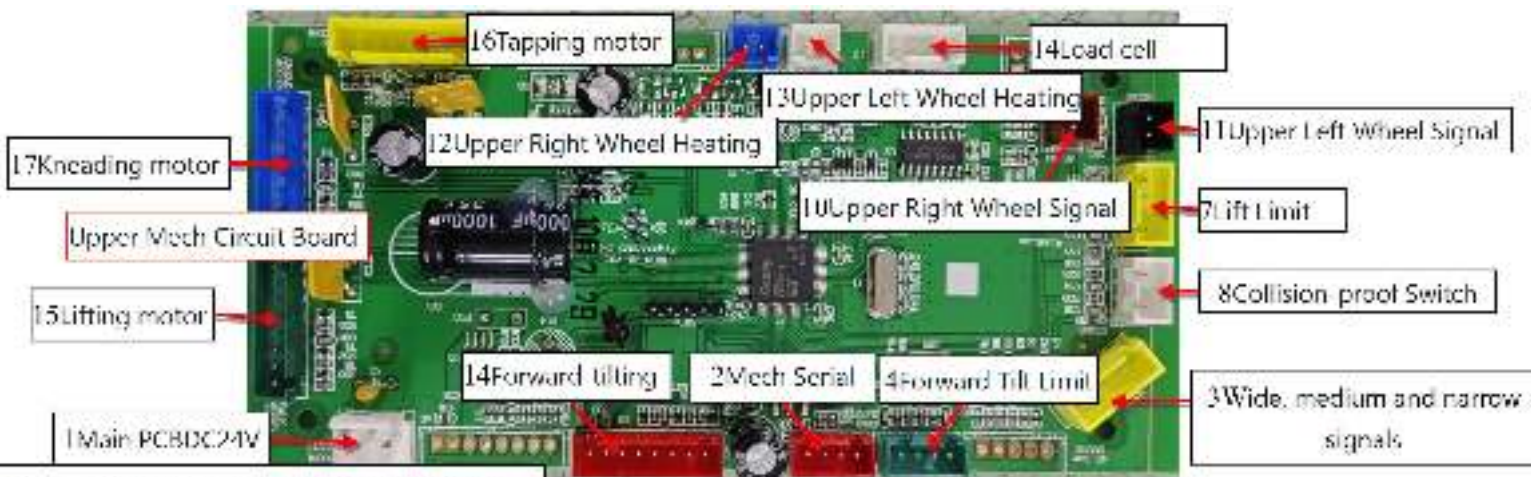
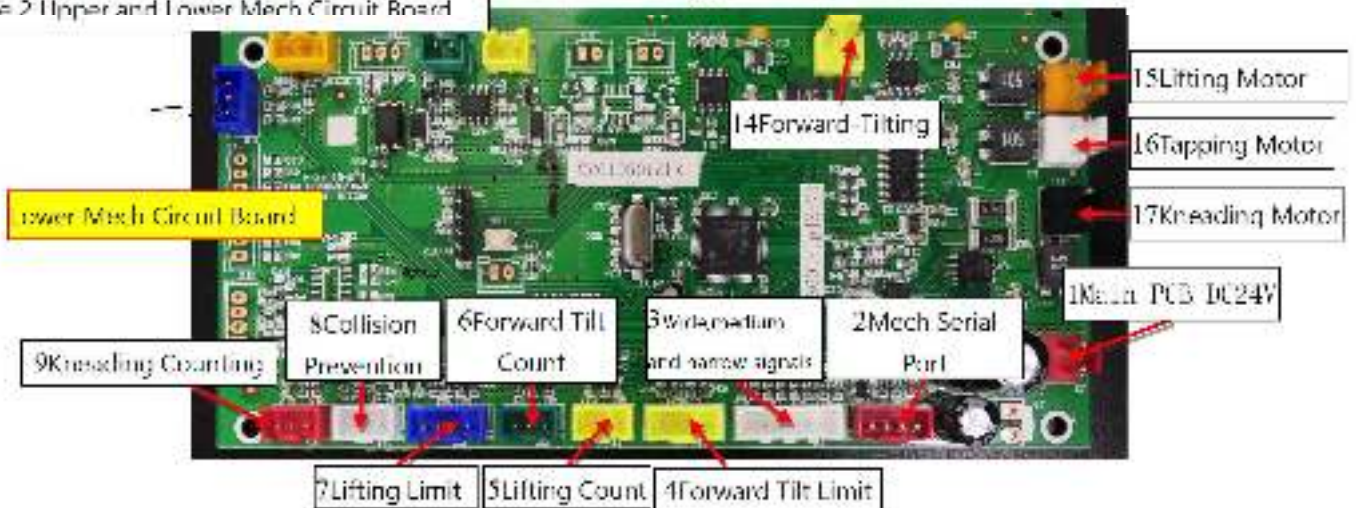
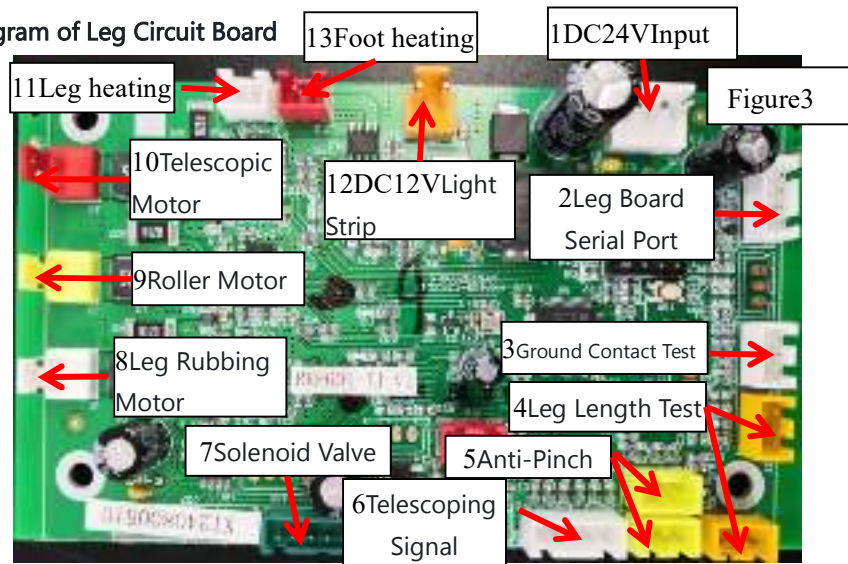

Figure 2 Upper and Lower Mech Circuit Board



Electrical Connection Diagram of Leg Circuit Board



Right Armrest Circuit Board Electrical Connection Diagram

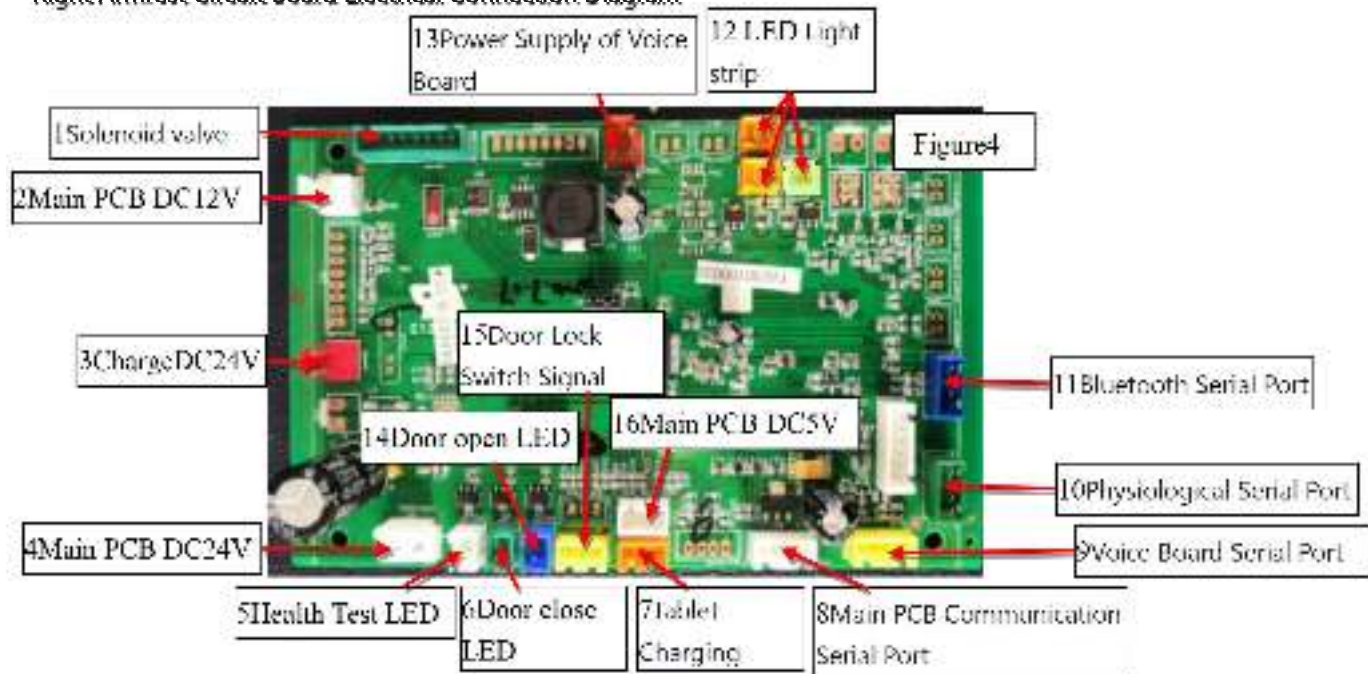

Electrical Connection Diagram of the Left Armrest Circuit Board

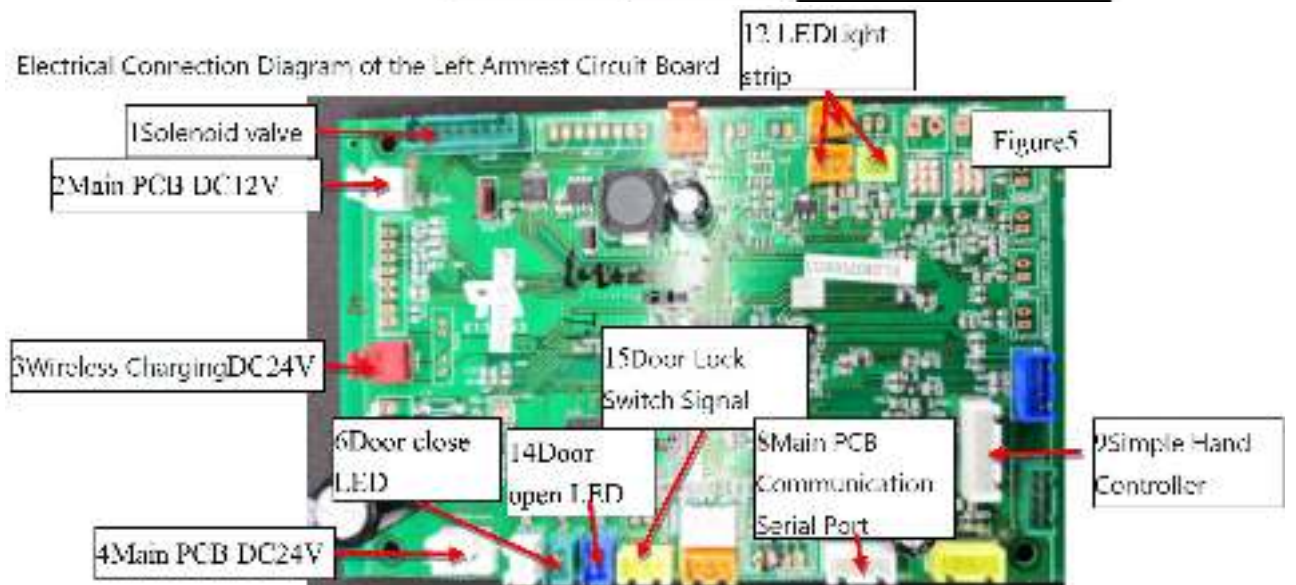

## **1.The massage chair does not work, and the hand controller has no display**

1.1 First, check if the socket has power. Turn on the switch of the three-in-one switch base, and judge whether the fuse of the three-in-one switch (1 in Figure 1) is blown. If the fuse is blown, it will work normally after replacement.

1.2 Use the AC voltage range of a multimeter to measure the voltage at the power input (AC220V) (2). If the voltage is abnormal, check whether the filter and filter board are faulty and the connection is normal; if abnormal, replace them.

1.3 Use the AC and DC voltage ranges of a multimeter to measure the voltages at the switching power supply input (AC220V) (3) and switching power supply output (DC24V) (4). If the voltage at 3 is normal but there is no voltage at 4, the switching power supply is faulty and will work normally after replacement. Measure whether the voltage at the adapter board input (DC24V) (5) is normal; if not, replace the mating wiring harness.

1.4 Use the DC voltage range of a multimeter to measure whether the standby voltage and DC5V voltage at 25 of the main board are normal. If there is no voltage, check whether the connecting wire between the adapter board and the main board is in good contact. If there is no problem, the adapter board should be faulty and will work normally after replacement. If the 5V voltage is normal, power on and measure whether the standby voltage (white and black wires) is high level (DC5V). If it does not change all the time, the main board is faulty and can be replaced directly;

1.5 The tablet has no display. Press the power button of the tablet to see if it can be turned on normally. If it cannot be turned on, charge it on the chair for a period of time and then press the power button. If it can be turned on, it is caused by a dead battery, and it can be used after being fully charged. Otherwise, replace the tablet.

1.6 The simple hand controller has no display and does not work. Use the DC voltage range of a multimeter to measure whether there is DC5V voltage at both ends of the connector inserted into the simple hand controller. If yes, replace the simple hand control board assembly. Check whether the wiring harness of the simple hand controller (9 on the left armrest board in Figure 5) is connected properly and the connector is inserted normally. If abnormal, replace the simple hand control wire assembly.

## **2. The up-and-low mech and support rods do not operate, while other functions work normally, and the simple hand controller displays properly**

2.1 Use the DC voltage range of a multimeter to measure whether the DC24V input voltage at 22 of the main board is normal. If there is no voltage, measure whether there is an output of about DC24V at the output (DC24V) of the converter board (as shown in Electrical Connection Diagram 4). If yes, replace the wiring harness between them; 2.2 If there is no voltage output, use the DC range to measure whether there is voltage input at the input (DC24V) of the adapter board (5 in Figure 1). If there is voltage, the converter board is faulty and will work normally after replacement.

2. The up-and-low mech and support rods do not operate, while other functions work normally, and the simple hand controller displays properly

2.1 Use the DC voltage range of a multimeter to measure whether the DC24V input voltage at 22 of the main board is normal. If there is no voltage, measure whether there is an output of about DC24V at the output (DC24V) of the converter board (as shown in Electrical Connection Diagram 4). If yes, replace the wiring harness between them;

2.2 If there is no voltage output, use the DC range to measure whether there is voltage input at the input (DC24V) of the adapter board (5 in Figure 1). If there is voltage, the converter board is faulty

and will work normally after replacement.

### 3. Abnormal Lifting of the Upper Mech

3.1 When the massage mechanism is in the upward and downward operation state, the lifting of the massage mechanism fails to operate or operates unidirectionally;

3.1.1 Turn on the tablet hand controller and manually send the full-stroke operation command to the upper mech. Use the DC voltage range of a multimeter to measure whether there is DC24V voltage output between pins 1&2 and pins 3&4 of the green connector (15) on the upper mech circuit board (as shown in Figure 2). If there is no voltage, the mech board is faulty and will work normally after replacement;

3.1.2 If the voltage is normal, measure whether there is voltage output between pin 7 and pin 3. If not, replace the mech board; manually stop and start the lifting function, and measure whether the voltage between pin 5 and pin 3 remains high level. If it remains high level, the mech board is faulty and can be replaced directly.

3.1.3 If the above voltages are normal, unplug the connector and use the buzzer range of a multimeter to measure the continuity of the red, black, yellow, brown, blue and white wires from the mech board to the lifting motor connector. Check whether the connector is plugged firmly and the terminals are in good contact. If all connections are normal, the lifting motor is faulty, and the lifting motor or the mech needs to be replaced; otherwise, the mating wiring harness needs to be replaced.

3.1.4 You can also plug the lifting motor drive wiring harness into other brushless motors of the mech to test if it can work. If it works, the lifting motor is faulty; otherwise, the mech board is faulty.

3.1.5 If the lifting motor can only operate in one direction, there is a fault in the lifting motor direction signal. Use the DC range of a multimeter to measure the voltage between pin 8 and pin 3 of the lifting motor connector (15) on the upper mech. Manually perform upward and downward operations and check for high-low level changes. If there is no change, replace the mech board. Measure whether there is high-low level change between pin 2 and pin 6 of the lifting motor connector. If not, replace the lifting motor drive wiring harness; otherwise, replace the lifting motor or the mech.

3.2 When the massage mechanism is in the upward and downward operation state, if it hits the top or bottom (exceeds the limit), there is a fault in the upper and lower limit signals of the lifting motor.



3.2.1 Check whether the connector at the lifting limit (7) on the upper mech circuit board (Figure 2) is loose from the connector on the upper and lower limit board in the red frame of the right figure, and whether the connector terminals are loose.

3.2.2 Measure whether there is DC5V at both ends of the connector in the red frame of the right figure. If normal, check whether the lifting limit Hall element has high-low level changes (use a magnet to approach or move away from the Hall element, and measure pins 2&3 of the upper limit or lower limit connector in the red frame). If there is no level change between pins 2&3, replace the lifting limit board.

3.2.3 Unplug the connector at 7 on the upper mech circuit board (Figure 2), and use the buzzer range of a multimeter to measure the continuity of the wiring harness between the mech board and the upper and lower limit board. If all are connected, the mech board is faulty and can be replaced directly; if not connected, replace the corresponding lifting limit wiring harness.

3.3 If the massage mechanism fails to operate in a specific area of the shoulder-back or waist-back and only runs the full stroke (between limits), there is a fault in the lifting motor signal.

3.3.1 After measurement according to Step 3.1, use the buzzer range of a multimeter to check whether the continuity of the blue and black wires from the mech board to the lifting motor is normal. If abnormal, replace the lifting motor drive wiring harness;

3.3.2 If connected, put the massage mechanism in upward and downward operation state, and use the DC voltage range of a multimeter to measure whether there is high-low level change between the blue and black wires. If yes, the mech board is faulty; otherwise, replace the lifting motor or the mech.

3.4 When the machine is turned on and enters a program, the upper mech starts shoulder height detection. If the massage mechanism stops slightly after moving at the upper limit or stops at the back, there is a fault in shoulder height detection.

3.4.1 First, check whether the mech is in the wide position. If not and the magnet is installed normally, replace the width detection board (check according to the wide-medium-narrow steps in the abnormal tapping of the upper mech); then check whether the tilting motor extends normally. If not, check the tilting function according to the abnormal steps of the upper mech tilting motor.

3.4.2 Use the DC range of a multimeter to measure whether the voltage between pins 1&2 of the load cell connector (14) on the upper mech board (Figure 2) is about DC3V. If not, replace the mech board;

3.4.3 Use the resistance range of a multimeter to measure whether the resistance between pins 1&2 and pins 3&4 of the load cell is about  $1K\Omega$ . If the resistance is too small or too large, the sensor is faulty, and the pressure sensor or the mech needs to be replaced;

3.5 Abnormal anti-collision switch. When the mech collides between the upper and lower limits, the lifting motor does not stop, indicating an abnormal anti-collision switch.

3.5.1 Check whether the connector is plugged firmly and the terminals are loose. Unplug the anti-collision switch (8) on the upper mech diagram and use the buzzer range of a multimeter to measure the continuity of the wiring harness. If abnormal, replace the corresponding wiring harness assembly.

3.5.2 Use the buzzer range of a multimeter to measure the red and black wires of the anti-collision switch. Press and release the anti-collision switch to check whether the switch is normally on and off. If abnormal, replace the anti-collision switch wiring harness assembly; otherwise, replace the mech board.

3.6 If the lower mech remains stationary at the lower limit position and the signals and circuits of the lower mech are normal, check whether the anti-collision switch of the upper mech is open or the connector is loose. Conversely, if the upper mech remains stationary at the upper limit position and the signals and circuits are normal, also check whether the anti-collision switch of the lower mech is open or the connector is loose.

#### **4. Abnormal Kneading of the Upper Mech**

4.1 The massage mechanism has no kneading action.

4.1.1 Turn on the tablet for manual control and send a kneading command to the massage mechanism. Use the DC voltage range of a multimeter to measure whether there is DC24V voltage output between pins 1&2 and pins 3&4 of the blue connector (17) on the upper mech circuit board (as shown in Figure 2). If there is no voltage, the mech board is faulty and will work normally after replacement;

4.1.2 If the voltage is normal, measure whether there is voltage output between pin 7 and pin 3. If not, replace the mech board; manually stop and start the kneading function, and measure whether

the voltage between pin 5 and pin 3 remains high level. If it remains high level, the mech board is faulty and can be replaced directly.

4.1.3 If the above voltages are normal, unplug the connector and use the buzzer range of a multimeter to measure the continuity of the red, black, yellow, brown, blue and white wires from the mech board to the kneading motor connector. Check whether the connector is plugged firmly and the terminals are in good contact. If all connections are normal, the kneading motor is faulty, and the kneading motor or the mech needs to be replaced; otherwise, the mating wiring harness needs to be replaced.

4.1.4 You can also plug the kneading motor drive wiring harness into other brushless motors of the mech to test if it can work. If it works, the kneading motor is faulty; otherwise, the mech board is faulty.

## 5. Abnormal Tapping of the Upper Mech

5.1 The massage mechanism has no tapping action. Test the tapping motor according to the steps for abnormal kneading of the upper mech in 4.1. The port is the kneading motor (17) of the upper mech.

5.2 Turn on the tablet and set it to tapping mode. If the wide/medium/narrow modes cannot be selected or are incorrect, there is a fault in the wide/medium/narrow signal of the mech.

5.2.1 Use the DC voltage range of a multimeter to measure whether there is 5V/DC output from the red and white wires of the connector at the wide/medium/narrow signal (3) on the upper mech board. If there is no output, the mech board is faulty and will work normally after replacement.

5.2.2 If there is voltage output, check whether the connector from position 3 of the upper mech board to the mech width signal on the right figure is plugged firmly and whether the terminals are loose. If all are normal, use the buzzer range of a multimeter to measure the continuity of the red, green, yellow and white wires at position 3 to the width signal terminal on the right figure. If not connected, replace the wide/medium/narrow detection wiring harness assembly.



5.2.3 If all are connected, use a magnet to approach and move away from the Hall element, and measure whether there is voltage change between the green&black wires and yellow&black wires. If not, the wide/medium/narrow detection board is damaged, and the circuit board or the mech needs to be replaced; otherwise, replace the upper mech board.

5.2.4 If kneading continues when wide or medium mode is selected, use the DC voltage range of a multimeter to measure whether there is high-low level change between the blue and black wires. If yes, the mech board is faulty; otherwise, replace the tapping motor or the mech.

## 6. Abnormal Tilting Forward of the Upper Mech

6.1 The massage mechanism has no tilting forward action. Test the tilting motor according to Step 3.1 (when the massage mechanism is in the upward and downward operation state, the lifting fails to operate or operates unidirectionally) for the upper mech. The port is the tilting motor (14) of the upper mech.

6.2 The massage mechanism fails to reach the correct tilting forward position or exceeds the limit, indicating a tilting forward counting fault. This situation has two scenarios: one is a counting fault of the tilting motor, which will work normally after replacement (see 3.3); the other is a change in the position of the "magnet sensing plastic part" in Figure 4. The solutions are as follows: 1. As shown in Figure 6, ensure that the gear is fully meshed with the second tooth of the rack. If not fully meshed, adjust the rotating shaft of the tilting motor until meshed. Align the magnet of the plastic part with the lower Hall element and fix it.



6.3 Tilting forward hits the top or bottom.

6.3.1 Check whether the connector at the tilting forward limit (4) on the upper mech circuit board (Figure 2) is loose from the connector on the upper and lower limit board in the red frame of the right figure, and whether the connector terminals are loose.



6.3.2 Measure whether there is DC5V at both ends of the connector in the red frame of the right figure. If normal, check whether the lifting limit Hall element has high-low level changes (use a magnet to approach or move away from the Hall element, and measure whether there is high-low level change between pin 2 (green), pin 3 (yellow) and pin 4 (white) of the connector in the red frame). If there is no level change, replace the 3D tilting forward board assembly.

6.3.3 Unplug the connector at 4 on the upper mech circuit board (Figure 2), and use the buzzer range of a multimeter to measure the continuity of the wiring harness between the mech board and the 3D limit board. If all are connected, the mech board is faulty and can be replaced directly; if not connected, replace the tilting forward limit wiring harness assembly.

## 7. Abnormal Lifting of the Lower Mech

7.1 When the massage mechanism is in the upward and downward operation state, the lifting of the massage mechanism fails to operate;

7.1.1 Turn on the tablet hand controller and manually send the full-stroke operation command to the upper mech. Use the DC voltage range of a multimeter to measure whether there is a voltage output (about DC24V) at the connector (15) in Figure 2 of the mech board. If there is no voltage, the mech board is faulty and will work normally after replacement;

7.1.2 If the voltage is normal, unplug the connector and use the buzzer range of a multimeter to measure the continuity of the red and black wires from the mech board to the white 3-core 450B connector of the lifting motor. Check whether the mating connector is plugged firmly and the terminals are in good contact. If all connections are normal, the lifting motor is faulty, and the lifting motor or the mech needs to be replaced; if the two wires are disconnected, the mating wiring harness needs to be replaced;

7.1.3 To determine if the lifting motor is damaged, set the multimeter to the resistance range and measure the resistance between the two ends of the lifting motor connector. If the resistance is 5-30 $\Omega$ , it is normal; if there is no resistance or the resistance is too large, the motor is damaged.

7.2 When the massage mechanism is in the upward and downward operation state, if it hits the top or bottom (exceeds the limit), there is a fault in the upper and lower limit signals of the lifting motor.

7.2.1 Check whether the connector at the lifting limit (7) in Figure 2 of the mech board is loose from the connector on the upper and lower limit board in the red frame of the right figure, and whether the connector terminals are loose.



7.2.2 Measure whether there is DC5V at both ends of the connector in the red frame of the right figure. If normal, check whether the lifting limit Hall element has high-low level changes (use a magnet to approach or move away from the Hall element, and measure pins 2&3 of the upper limit or lower limit connector in the red frame). If there is no level change between pins 2&3, replace the lifting limit board.

7.2.3 Unplug the connector at 7 in Figure 2, and use the buzzer range of a multimeter to measure the continuity of the wiring harness between the mech board and the upper and lower limit board. If all are connected, the mech board is faulty and can be replaced directly; if not connected, replace the corresponding lifting limit wiring harness.

7.3 If the massage mechanism fails to operate in a specific area of the shoulder-back or waist-back and only runs the full stroke (between limits), there is a fault in the lifting counting signal at 5 of the mech board (Figure 2).

7.3.1 Check whether the connector from the mech board to the tilting motor limit board is loose and whether the terminals are loose. Unplug the signal input wire on the tilting motor limit board in the right figure, and measure the continuity of the red, brown, orange, yellow, blue and black wires corresponding to 4, 5, 6 (red, brown, orange, yellow, blue, black) of the mech board. If not connected, replace the tilting signal wiring harness.

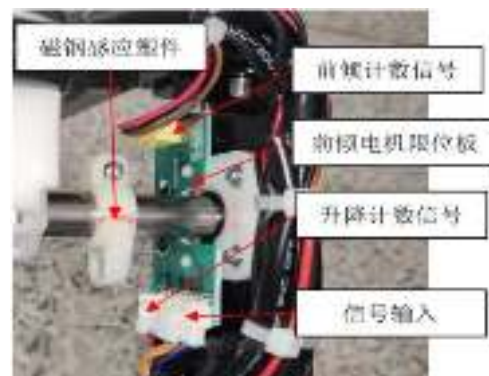

7.3.2 If all are connected, put the massage mechanism in upward and downward operation state, and use the DC voltage range of a multimeter to measure whether there is DC5V voltage between the red and black wires of the signal input of the tilting limit board in the above figure. If not, the mech board is faulty; if yes, measure whether there is high-low level change between the brown and black wires of the lifting counting signal. If not, the lifting motor counting function is faulty and can be replaced directly. During maintenance, do not adjust the position of the magnet of the magnet sensing plastic part and the Hall element of the tilting motor limit board; otherwise, it will also cause faults in the upward/downward movement or tilting counting of the mech.

7.4 Abnormal anti-collision switch. When the mech collides between the upper and lower limits, the lifting motor does not stop, indicating an abnormal anti-collision switch.

7.4.1 Check whether the connector is plugged firmly and the terminals are loose. Unplug the anti-collision switch (8) and use the buzzer range of a multimeter to measure the continuity of the wiring harness. If abnormal, replace the corresponding wiring harness assembly.

7.4.2 Use the buzzer range of a multimeter to measure the red and black wires of the anti-collision switch. Press and release the anti-collision switch to check whether the switch is normally on and off. If abnormal, replace the anti-collision switch wiring harness assembly; otherwise, replace the mech board.

7.5 If the lower mech remains stationary at the lower limit position and the signals and circuits of the lower mech are normal, check whether the anti-collision switch of the upper mech is open or the connector is loose. Conversely, if the upper mech remains stationary at the upper limit position

and the signals and circuits are normal, also check whether the anti-collision switch of the lower mech is open or the connector is loose.

## 8. Abnormal Kneading of the Lower Mech

8.1 The massage mechanism has no kneading action.

8.1.1 Turn on the tablet for manual control and send a kneading command to the massage mechanism. Use the DC voltage range of a multimeter to measure whether there is a voltage output of about DC9-20V at the terminals of the connector at the kneading motor (17) on the mech board. If there is no voltage output, the mech board is faulty and can be replaced directly.

8.1.2 If there is voltage output, check whether the mating connector of the wiring harness from position 17 to the kneading motor is plugged firmly and the terminals are in good contact. If normal, unplug the connector and use the buzzer range of a multimeter to measure the continuity of the red and black wires at the mech board connector (17) to both ends of the black 2-core 450B connector. If all are connected, the kneading motor is faulty, and the mech needs to be replaced; if not connected, the kneading motor wiring harness assembly needs to be replaced. The method for judging whether the kneading motor is damaged is the same as the method for judging the lifting motor in 3.1.3.

8.2 If the kneading function of the massage chair starts running as soon as it is turned on and cannot be turned off through the tablet operation, the mech board is faulty and can be replaced directly.

## 9. Abnormal Tapping of the Lower Mech

9.1 The massage mechanism has no tapping action.

9.1.1 Turn on the tablet for manual control and send a tapping command to the massage mechanism. Use the DC voltage range of a multimeter to measure whether there is a voltage output of about DC9-20V at both ends of the connector at the tapping motor (16) on the mech board. If there is no voltage, the mech board is faulty and will work normally after replacement.

9.1.2 If the voltage of the mech board is normal, check whether the mating connector from the mech board to the tapping motor is plugged firmly and the terminals are in good contact. If normal, unplug the connector and use the buzzer range of a multimeter to measure the continuity of the red and black wires from the mech board connector (16) to the white 2-core 450B connector. If all are connected, the tapping motor is faulty, and the mech needs to be replaced; if the two wires are disconnected, the tapping motor wiring harness assembly needs to be replaced. The method for judging whether the tapping motor is damaged is the same as the method for judging the lifting motor in 7.1.3.

9.2 If the tapping function of the massage chair starts running as soon as it is turned on and cannot be turned off through the tablet operation, the mech board is faulty and needs to be replaced.

9.3 Turn on the tablet and set it to tapping mode. If the wide/medium/narrow modes cannot be selected or are incorrect, there is a fault in the wide/medium/narrow signal of the mech. Use the DC voltage range of a multimeter to measure whether there is 5V/DC output from the red and black wires of the connector at the wide/medium/narrow signal (3) on the mech board. If there is no output, the mech board is faulty and will work normally after replacement. If there is voltage output, check whether the connector from position 3 of the mech board to the mech width signal on the right figure is plugged firmly and



whether the terminals are loose. If all are normal, use the buzzer range of a multimeter to measure the continuity of the red, brown, yellow and black wires at position 3 to the width signal terminal on the right figure. If not connected, replace the wide/medium/narrow detection signal wiring harness assembly; if all are connected, use a magnet to approach and move away from the Hall element, and measure whether there is voltage change between the brown&black wires and yellow&black wires. If not, the wide/medium/narrow detection board is damaged and will work normally after replacement; otherwise, replace the mech board. If kneading continues when the medium width mode is selected, use the DC voltage range of a multimeter to measure whether there is DC5V voltage between the red and black wires at the kneading counting position (9) on the mech board. If not, replace the mech board; measure whether there is high-low level change between the yellow and black wires. If yes, replace the mech board. Use the same method to test whether the voltage between the red, yellow and black wires of the kneading counting board is normal. If there is no voltage, replace the kneading counting wiring harness; if the voltage is normal, replace the kneading counting board as shown in the right figure.



## 10. Abnormal Tilting Forward of the Lower Mech

10.1 The massage mechanism has no tilting forward action. Turn on the tablet for manual control and send a tilting forward command to the massage mechanism. Set the multimeter to the DC voltage range and measure whether the voltage output at both ends of the connector at the tilting motor (14) on the mech board is normal. If there is no voltage, the mech board is faulty and will work normally after replacement. If the voltage is normal, check whether the mating connector of the wiring harness from the mech board to the tilting motor is plugged firmly and the terminals are in good contact. Then use the buzzer range of a multimeter to measure the continuity of the red and black wires at position 14 of the mech board to the black 3-core 450B connector mated with the tilting motor wiring harness. If all are connected, the tilting motor is damaged, and the tilting motor or the mech needs to be replaced; if not connected, the tilting motor wiring harness assembly needs to be replaced. The method for judging whether the tilting motor is damaged is the same as the method for judging the lifting motor in 7.1.3.

10.2 The massage mechanism fails to reach the correct tilting forward position or exceeds the limit, indicating a tilting forward counting fault. This situation has two scenarios: one is a fault of the tilting forward counting board, which will work normally after replacement (see 10.3); the other is a change in the position of the "magnet sensing plastic part" in Figure 4. The solutions are as follows: 1. As shown in Figure 6, ensure that the gear is fully meshed with the second tooth of the rack. If not fully meshed, adjust the rotating shaft of the tilting motor until meshed. Align the magnet of the plastic part with the lower Hall element and fix it.



10.3 Tilting forward hits the top or bottom. Set the multimeter to the DC voltage range, use a magnet to approach and move away from the Hall element, and measure whether the voltage output between the brown, orange and black wires of the connector at the tilting forward limit (4) on the mech board is normal. If there is voltage, the mech board is

faulty and will work normally after replacement; if there is no voltage, check whether the continuity of the wiring harness from the mech board to the tilting forward limit board is normal. If the continuity is normal, replace the tilting motor limit board; otherwise, replace the tilting forward signal wiring harness assembly.

### 11. No Inflation for the Entire Machine or One Circuit

11.1 If the entire machine does not inflate, after turning on the power, use the AC voltage range of a multimeter to measure whether there is a voltage of about AC24V at the two connectors at position 7 of the main board. If yes, check for loose connectors and wiring harness continuity issues; if normal, the air pump is faulty and needs to be replaced. If there is no voltage output and the voltage at position 22 is normal, the main board is faulty and can be replaced directly.

11.2 Check for loose, blocked, kinked, poorly connected, damaged or air-leaking air pipes;

11.3 If one specific circuit does not inflate:

11.3.1 Use the DC voltage range of a multimeter to measure whether there is DC24V voltage output at the corresponding port of this circuit. If no output, the corresponding main board or armrest board is faulty and can be replaced directly.

11.3.2 Alternatively, turn off the power, use the buzzer range of a multimeter to check for abnormal continuity of the wiring harness to the solenoid valve; replace if abnormal. Use the ohm range of a multimeter to measure the resistance of the solenoid valve corresponding to this circuit (solenoid valve resistance:  $165 \pm 10\%$ ). If there is no resistance or the resistance is too large, the solenoid valve is faulty and can be replaced directly.

11.3.3 Check for kinked or loose air pipes between the solenoid valve and the airbag;

11.4 If inflation is weak, check for blockages, air leaks, damage or other issues in the air pipes, solenoid valves and airbags.

11.5 For non-functional solenoid valves of the left/right armrests and leg/foot section: in addition to checking DC24V, also inspect the continuity of the wiring harness between the left armrest serial port (13), leg/foot serial port (15), right armrest serial port (34) of the main board and the main board communication serial port (8) of the left/right armrests, leg/foot board serial port (2) respectively. Verify that connectors are firmly plugged and terminals are not loose; replace the corresponding wiring harness if abnormal. Check for abnormalities in the mating wiring harness to the solenoid valve and replace if necessary.

The corresponding ports of the solenoid valves are as follows:

Whole machine section :



Right armrest section :



Left armrest section :



Leg and foot section :



## **12. Abnormal Action of Back Support Rod**

12.1 The electric support rod does not act.

12.1.1 Set the multimeter to DC voltage range, insert the two test leads into the terminals of the blue connector at the back support rod (20), operate the backrest lifting button on the tablet hand controller, and observe whether the multimeter has DC24V output. If there is no voltage, the main board is faulty and will work normally after replacement.

12.1.2 Check whether the wiring harness between position 20 and the mating connector of the support rod is plugged firmly and whether there are loose terminals. Check the continuity of the wiring harness; if broken, replace the corresponding wiring harness assembly. Unplug the mating connector of the support rod, check the resistance between the two wires of the support rod. If the support rod is at the upper or lower limit, measure with the diode range, test in both directions; one-way conduction indicates it is good. In other positions, a resistance of 3-20 $\Omega$  is normal; otherwise, the electric support rod motor is damaged, and the electric support rod should be replaced.

12.2 The electric support rod cannot stop at the initial massage position.

12.2.1 Set the multimeter to DC voltage range, insert the two test leads between the green and gray wires of the connector at the support rod counting signal (33), operate the backrest lifting button on the tablet hand controller, and observe whether the multimeter has high-low level output. If there is high-low level, the main board is faulty and will work normally after replacement.

12.2.2 Check the continuity of the wiring harness to the support rod and whether the connector is plugged firmly. If normal, the support rod is faulty and will work normally after replacement; otherwise, replace the corresponding wiring harness assembly.

## **13. Abnormal Action of Leg Support Rod**

13.1 The electric support rod does not act.

13.1.1 Set the multimeter to DC voltage range, insert the two test leads into the terminals of the green connector at the leg support rod (19), operate the backrest lifting or leg lifting button on the tablet hand controller, and observe whether the multimeter has DC24V output. If there is no voltage, the main board is faulty and will work normally after replacement.

13.1.2 Check whether the wiring harness between position 19 and the mating connector of the support rod is plugged firmly and whether there are loose terminals. Check the continuity of the wiring harness; if broken, replace the corresponding wiring harness assembly. Unplug the mating connector of the support rod, check the resistance between the two wires of the support rod. If the support rod is at the upper or lower limit, measure with the diode range, test in both directions; one-way conduction indicates it is good. In other positions, a resistance of 3-20 $\Omega$  is normal; otherwise, the electric support rod motor is damaged, and the electric support rod should be replaced.

13.2 The electric support rod cannot stop at the initial massage position.

13.2.1 Set the multimeter to DC voltage range, insert the two test leads between the yellow and black wires of the connector at the support rod counting signal (33), operate the backrest lifting button on the tablet hand controller, and observe whether the multimeter has high-low level output. If there is high-low level, the main board is faulty and will work normally after replacement.

13.2.2 Check the continuity of the wiring harness to the support rod and whether the connector is plugged firmly. If normal, the support rod is faulty and will work normally after replacement; otherwise, replace the corresponding wiring harness assembly. Interchange check of electric

support rods: When there is no obvious burnout on the faulty circuit board, interchange the power supply and signal of the leg and back support rods simultaneously, i.e., replace the faulty support rod with the normal support rod circuit, operate the normal support rod function. If the support rod works normally, the circuit board is faulty; otherwise, the electric support rod is faulty and should be replaced.

#### **14. Foot Roller Not Working**

14.1 Turn on the foot roller function (leg and foot air pressure), but it does not work. Use the DC voltage range of a multimeter to measure whether there is DC24V and DC5V at the 1DC24V input and 2 leg/foot board serial port connector in Figure 3. If abnormal, check the mating of connectors and wiring harness continuity between the leg/foot board and the main board; replace the mating wiring harness if abnormal.

14.2 Set the multimeter to DC voltage range, insert the two test leads into the terminals of the roller motor connector at position 9 in Figure 3, and check if the output voltage is normal. If there is no voltage, the leg/foot board is faulty. If there is voltage output, use the multimeter to measure whether the voltage between the red and black wires of the 450 connector at the other end of this wiring harness is 24V. If no voltage, replace this wiring harness assembly; otherwise, the roller motor is faulty and should be replaced.

#### **15. Leg Rolling Motor Not Working**

15.1 Turn on the leg roller function (leg and foot air pressure), but it does not work. First, check for wiring harness issues between the leg/foot board and the main board according to 10.1.

15.2 Set the multimeter to DC voltage range, insert the two test leads into the terminals of the leg rolling motor connector at position 8 in Figure 3, and check if the output voltage is normal. If there is no voltage, the leg/foot board is faulty. If there is voltage output, use the multimeter to measure whether the voltage between the brown and blue wires of the 450 connector at the other end of this wiring harness is 24V. If no voltage, replace this wiring harness assembly; otherwise, the leg rolling motor is faulty and should be replaced.

#### **16. Abnormal Operation of Telescopic Motor First, check for wiring harness issues between the leg/foot board and the main board according to 14.1.**

16.1 The telescopic motor does not work

16.1.1 Check whether the connectors of the motor and limit wiring harness are firmly plugged, whether the mating connectors are secure, and whether terminals are loose.

16.1.2 Set the multimeter to DC voltage range, insert the two test leads into the terminals of the telescopic motor connector at position 10 in Figure 3, operate the leg telescopic button on the tablet hand controller, and observe whether the multimeter has DC24V output. If no voltage, the leg/foot board is faulty and will work normally after replacement. Unplug the telescopic wiring harness mated with the motor and measure for DC24V output; if no voltage, the telescopic wiring harness is damaged and should be replaced.

16.1.3 Check the resistance between the two wires of the telescopic motor (normal range: 5-30 $\Omega$ ).

No resistance or excessively high resistance indicates a motor fault; replace the motor.

16.1.4 Use the DC range of a multimeter to measure the voltage between the green, yellow, white wires and the black wire of the telescopic counting signal wiring harness at J9 of the leg/foot board. Block the photoelectric switch of the counting board respectively to check for level changes. If there is voltage change, replace the leg/foot board. Check if the connecting wiring harness is conductive; replace if disconnected. Otherwise, replace the counting board.

16.2 Leg and foot section extends when the machine is turned on

16.2.1 Check if the foot detection sensor is damaged. Use the DC range of a multimeter to measure whether there is DC5V at pins 1 and 3 of the leg length detection (4) in Figure 3. If no voltage, replace the leg/foot board.

16.2.2 Use the buzzer range of a multimeter to check the continuity of the red, blue, and black wires of the left and right leg length detection wiring harnesses; replace if disconnected. Use the DC range of a multimeter to measure the voltage between the blue and black wires of the orange connector. Press and release the foot detection sensor to check for high-low level changes. If there is voltage change, the leg/foot board is faulty and should be replaced; otherwise, replace the foot detection sensor.

16.3 Leg and foot section does not extend After checking according to 12.1, use the DC range of a multimeter to measure whether there is voltage change between the blue and black wires of the ground contact detection J23 (3) on the leg/foot board. If no change, replace the ground contact detection assembly; otherwise, replace the leg/foot board.

16.4 Leg and foot section does not retract After checking according to 14.1:

16.4.1 Check if the anti-pinch detection board is damaged. If the indicator light stays on, replace the anti-pinch detection board.

16.4.2 Use the buzzer range of a multimeter to check the continuity of the red, blue, and black wires of the anti-pinch wiring harness; replace if disconnected. Use the DC range of a multimeter to measure whether there is voltage change between the blue and black wires of the leg length detection J24 and J25 (4). If no change, replace the anti-pinch detection board assembly; otherwise, replace the leg/foot board.

## **17. Leg Heating Pad Not Working**

17.1 Turn on the leg heating function on the tablet. First, check for wiring harness issues between

the leg/foot board and the main board according to 14.1. Check whether the connectors between the heating pads are firmly plugged and whether terminals are loose.

17.2 Measure whether the voltage at the heating position (11) in Figure 3 is DC24V. If no voltage output, the leg/foot board is damaged. If there is voltage output, use a multimeter to measure whether the heating wire connector has DC24V; if no, replace the heating wire; if yes, replace the heating pad.

### **18. Foot Heating Pad Not Working**

18.1 Turn on the foot heating function on the tablet. First, check for wiring harness issues between the leg/foot board and the main board according to 14.1. Check whether the connectors between the heating pads are firmly plugged and whether terminals are loose.

18.2 Measure whether the voltage at the heating position (13) in Figure 3 is DC24V. If no voltage output, the leg/foot board is damaged. If there is voltage output, use a multimeter to measure whether the heating wire connector has DC24V; if no, replace the heating wire; if yes, replace the heating pad.

### **19. Waist Heating Pad Not Working**

19.1 Check whether the connector at position 32 is firmly plugged and whether terminals are loose, whether the DC plug of the waist heating wiring harness is securely connected, and whether the internal heating wire of the back pad is broken.

19.2 Turn on the waist heating function on the tablet, set the multimeter to DC voltage range, insert the two test leads into the terminals of the blue connector at the waist heating position (32), and measure for DC24V. If no voltage, the main board is damaged and should be replaced. Measure whether the DC connector of the back heating wire has DC24V output; if no, check the continuity of the heating wiring harness and the connector mating between the back heating wire and the main board; replace if faulty. If there is voltage, the heating pad is damaged and should be replaced.

### **20. Abnormal Health Test Function**

20.1 Normal startup control, but health monitoring cannot be detected when turned on via the tablet. Check if the contact surface of the health test module is severely dirty or blocked; clean it if necessary.

20.2 Inspect the wiring harness and connectors between the right armrest circuit board (10) and the left armrest health test module. Verify if the connectors are firmly plugged, terminals are not loose, and the wiring harness continuity is normal. Reconnect if loose; replace the corresponding wiring harness assembly if continuity is abnormal.

20.3 Use the DC voltage range of a multimeter to measure whether there is voltage output (DC5V) between the white and gray wires of the health serial port (10) on the right armrest board, or between the red and black wires of the mating connector of the health test module. Replace the main board if no voltage output; otherwise, replace the health test module.

20.4 The health test LED does not light up. Measure whether there is DC5V between pin 1 and pin 2 of the health test LED connector (5) on the right armrest board. Replace the armrest board if no voltage; otherwise, replace the health test LED assembly.

## 21. Speaker Not Working, Voice Abnormality

21.1 Speaker not working: Connect a mobile phone via Bluetooth and play music. Measure the voltage at connector 21 on the main board to check for DC12V. If there is no voltage output, the main board is damaged.

21.2 Check whether there is DC12V voltage at the power supply J1 of the voice board (4). If no voltage, check the mating of the connector and the continuity of the wiring harness; replace the corresponding wiring harness if abnormal. If there is voltage output, use a multimeter in AC range to measure whether there is fluctuating voltage

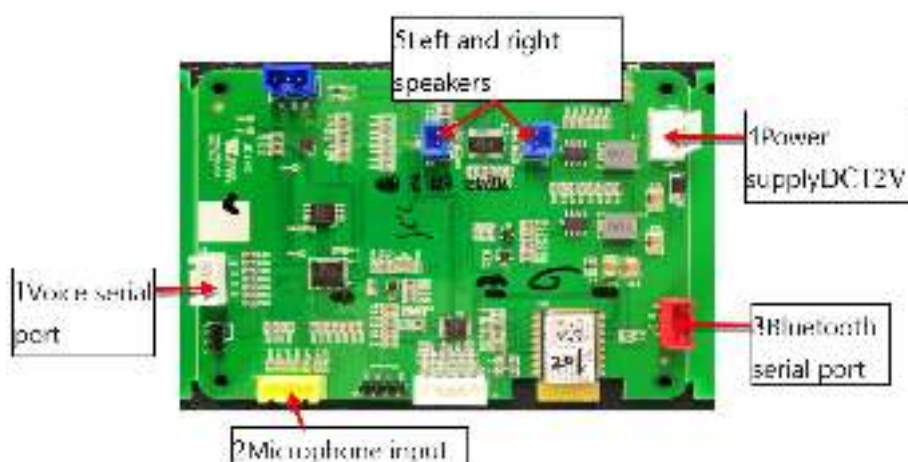

output at J2 and J3 (left and right speakers) on the power amplifier board (5). If no voltage, replace the voice board; if there is voltage, replace the speaker after confirming the left and right speaker wiring harnesses are intact.

21.3 Voice abnormality: If no issues are found in checks 21.1 and 21.2, inspect the connector between the voice board and the microphone assembly for secure mating, loose terminals, and normal wiring harness continuity. If normal, replace the microphone assembly; otherwise, replace the wiring harness.

21.4 Unrecognizable voice: If the fault persists after steps 1, 2, and 3, replace the voice board.

21.5 Voice not controlling: Use a multimeter in DC voltage range to measure whether there is DC5V across the voice serial port (1 in the above figure). If no voltage, check the continuity of the wiring harness and the connector mating between the voice board serial port and the right armrest board (9); replace the corresponding wiring harness if abnormal. Check for DC5V output across the connector on the right armrest board (9); if no voltage, replace the armrest board; otherwise, replace the voice board.

## 22. Anion Not Working

22.1 Turn on the anion function. Measure the voltage at the anion connectors J18 and J19 (24) on the main board to check for DC12V. If there is no voltage output, the main board is damaged.

22.2 Check for voltage between the main board and the shoulder mating connector. If no voltage, replace the corresponding wiring harness; if there is voltage output, replace the anion-related component assembly.

## 23. Aromatherapy Not Working

23.1 Turn on the tablet and sequentially activate the 5 aromatherapy modes. Measure the voltage at

the aromatherapy fan connector (23) on the main board to check for DC12V. If there is no voltage output, the main board is damaged and should be replaced.

23.2 Check for voltage between the main board and the shoulder mating connector. If no voltage, replace the corresponding wiring harness; if there is voltage output, replace the faulty aromatherapy fan.

23.3 Check whether the air pipe between the fan and the aromatherapy outlet is loose, leaking, etc., and whether the outlet is blocked.



## 24. Abnormal Charging

24.1 Abnormal wireless charging.

24.1.1 Use a multimeter in DC voltage range to measure whether there is DC24V output between the red and black wires of the wireless charging output (DC24V) at the left armrest circuit board (3). If there is no voltage, replace the armrest board.

24.1.2 Check whether the connector between the armrest board and the wireless charging board is firmly plugged and whether terminals are loose.

24.1.3 Measure whether there is DC24V voltage across the input connector of the wireless charging module. If no voltage, replace the wiring harness assembly between the conversion board and the charging board; otherwise, replace the wireless charging module (as shown in the right figure).



24.2 Abnormal USB charging.

24.2.1 Use a multimeter in DC voltage range to measure whether there is DC24V output between the red and black wires of the wireless charging output (DC24V) at the right armrest circuit board (3). If there is no voltage, replace the armrest board.

24.2.2 Check whether the connector between the USB charging board wiring harness and the right armrest board is firmly plugged and whether terminals are loose. If disconnected, replace the corresponding wiring harness assembly.



24.2.3 Connect a mobile phone for charging. Use a multimeter in DC voltage range to measure whether there is DC24V at the white 3.96 connector on the fast-charging module. If there is, measure whether there is voltage output between the red and black wires of the red output connector of the charging module (around DC5V; fast charging requires DC8V or above). If no voltage, replace the charging module. Check the continuity of the USB wiring harness; if disconnected, replace the wiring harness; otherwise, replace the USB circuit board.



### 24.3 Abnormal tablet charging.

24.3.1 Use a multimeter in DC voltage range to measure whether there is DC5V voltage across the charging pins in the right armrest tablet holder (as shown in the right figure). If no voltage, unplug the support rod and use the multimeter's buzzer range to check the continuity between the charging pins and the other end; if abnormal, replace the tablet support rod assembly.

24.3.2 Use a multimeter in DC voltage range to measure whether there is DC5V voltage across the tablet charging connector (7) on the right armrest board. If there is, replace the tablet charging wiring harness assembly 1 (the wiring harness between the circuit board and the tablet support rod).



24.3.3 Use a multimeter in DC voltage range to measure whether there is DC5V voltage across the DC5V input connector (16) from the main board on the right armrest board. If there is, replace the right armrest board.

24.3.4 Check whether the mating connector between the right armrest (16) and the right armrest DC5V power supply (14) on the main board is firmly plugged, whether terminals are loose, and whether the wiring harness continuity is normal. If abnormal, replace the corresponding wiring harness assembly.

24.3.5 Use a multimeter in DC voltage range to measure whether there is DC5V voltage across the right armrest DC5V power supply connector (14) on the main board. If no voltage, replace the main board; otherwise, replace the tablet.

24.3.6 If the entire machine malfunctions or shuts down when the tablet is placed on the tablet holder for charging, and the charging pins are normal, replace the tablet.

## 25. Abnormal Movement Heating

25.1 Check if the connector is loose. Use a multimeter in resistance range to measure the resistance of the 10 upper left wheel signal sensor and 11 upper right wheel signal sensor. The normal resistance is around  $5K\Omega$  (at  $25^{\circ}C$ ). If there is no resistance (or extremely high resistance) or extremely low resistance, replace the corresponding temperature sensor.

25.2 If the sensors are normal, turn on the machine and activate the heating function. If there is no DC24V output from the movement board's heating output, the movement board's sensor detection circuit is faulty; replace the movement board.

25.3 Turn on the machine and activate the heating function. Use a multimeter to measure whether there is DC24V output at the 12 upper right wheel heating connector and 13 upper left wheel heating connector. If no voltage output, replace the movement board.

25.4 Use a multimeter in resistance range to measure the resistance of the heating elements for 12 upper right wheel heating and 13 upper left wheel heating. If open-circuited, replace the corresponding heating element.

## 26. Abnormal LED Strip

26.1 Abnormal leg/foot LED. Turn on the machine and use a multimeter in DC range to measure whether there is DC12V output across the 12DC12V LED strip in Figure 3. If no output, the leg/foot board is faulty; replace it. Otherwise, replace the leg/foot LED strip assembly.

#### 26.2 Abnormal Armrest LED

26.2.1 Use a multimeter in buzzer range to check the continuity of the wiring harness between the main board's left/right armrest communication lines and the left/right armrests, and verify if the connectors are firmly plugged. If abnormal, replace the corresponding wiring harness assembly.

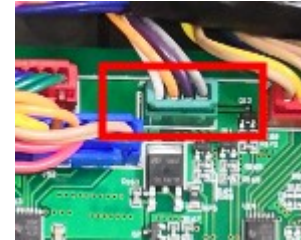

26.2.2 Turn on the machine. Use a multimeter in DC voltage range to measure whether there is DC12V voltage across the 12 LED strip connectors on the left and right armrest circuit boards. If no voltage, replace the armrest circuit board.

26.2.3 Use a multimeter in DC voltage range to measure whether there is DC12V across the mating connector. If there is voltage, replace the LED strip assembly; otherwise, replace the wiring harness.

#### 26.3 Abnormal Shoulder LED Strip

26.3.1 Turn on the machine, select additional functions, and activate the 5 phototherapy modes. Measure the voltage at the main board's

**27. shoulder LED connector (between pin 1 and pins 2, 3, 4) to check for DC12V. If no voltage output, the main board is damaged and should be replaced (as shown in the right figure).**

26.3.2 Check whether the connector between the main board and the shoulder LED strip is firmly plugged and whether terminals are loose; replace the corresponding wiring harness if abnormal.

26.3.3 Check for voltage between the main board and the shoulder LED strip mating connector. If no voltage, replace the corresponding wiring harness; if there is voltage output, replace the faulty shoulder LED strip.

#### 27. Abnormal Armrest Door Closing Signal

27.1 After closing the armrest, the red light is on, the chair malfunctions, and functions cannot be activated.

27.1.1 After closing the armrest, use a multimeter in DC range to measure whether the voltage between the red and black wires of the 15 door lock switch signal on the armrest board is low level. If yes, replace the armrest board.

27.1.2 Unplug the connector and use a multimeter in buzzer range to check if the red and black wires are conductive. If not conductive, check whether the door lock structure presses the limit switch. If pressed, replace the armrest door lock switch assembly; otherwise, adjust the door lock structure to ensure the switch is pressed when closed.

27.2 Abnormal Door Open/Close LED. Use a multimeter in DC range to measure whether there is DC5V voltage output across the 6 door closing LED and 14 door opening LED connectors on the armrest board when opening and closing the door respectively. If no voltage, replace the armrest board; otherwise, replace the armrest lock light assembly.

#### 28. Abnormal Tablet Control

28.1 Tablet does not display. Charge the tablet for a long time. Press the power button to check if it turns on; if not, press the reset button to restart. If still abnormal, replace the tablet.

28.2 Tablet cannot control the chair.

28.2.1 Turn on the tablet, enter the settings interface, and check if the Bluetooth switch is turned on and if it is connected to the massage chair's Bluetooth. If not, turn on Bluetooth and reconnect.

28.2.2 If Bluetooth connection fails, check if the voice board is normal according to 21.1. Use a multimeter in buzzer range to check the continuity of the wiring harness between the 3 Bluetooth serial port on the voice board and the right armrest board, and verify if the connector is firmly plugged and terminals are not loose. If abnormal, replace the Bluetooth communication cable.

28.2.3 Check the continuity of the wiring harness between the 8 main board communication port on the right armrest board and the 34 right armrest serial port on the main board, and verify if the connector is firmly plugged and terminals are not loose. If abnormal, replace the corresponding wiring harness.

28.2.4 Use a multimeter in DC voltage range to measure whether there is DC5V voltage across the 8 main board communication port on the right armrest board. If yes, replace the right armrest board. Measure whether there is DC5V voltage across the 34 right armrest serial port on the main board; if no, replace the main board.

28.3 Tablet cannot control during massage after startup. If the simple hand controller also cannot control, check if the left and right armrest door closing lights are red (indicating the armrests are opened during massage). Turn off the machine to reset, close the left and right armrests tightly, and restart. The left and right lights showing white indicate normal closing; if abnormal, check according to 27. Abnormal Armrest Door Closing Signal.

### III 、 Mechanical failures and solutions :

#### 1. Replace the massage mechanism

1.1 As shown in the figure, remove the 6 ST4.2\*16 screws with a Phillips screwdriver to take off the rear shield of the backrest.

1.2 As shown in Figure 2, remove the 6 4\*10 Phillips S-type cap head self-tapping screws with a Phillips screwdriver.

1.3 Unplug the wire harness connectors of the upper and lower movement assemblies. First, disassemble and take out the upper movement assembly, then remove the lower movement assembly.



The method of disassembling the massage machine: Rotate the lifting motor shaft. You can assist by putting an air pipe over the motor shaft to rotate it (or use a power tool to rotate it at a low speed).

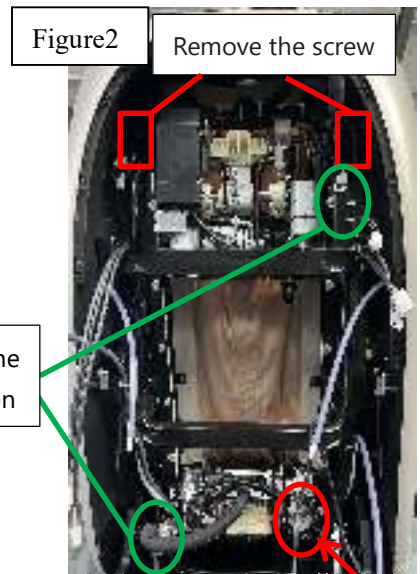

Figure2

Remove the screw

Unplug the connection

This lifting gear is a plastic part. The RK9501 uses a die-cast alloy gear, and the assembly method is the same.

When installing the massage mechanism: The lifting gears on both sides need to be kept symmetrically aligned.

Rotate the lifting motor shaft here to disengage the massage mech from the guide rail.

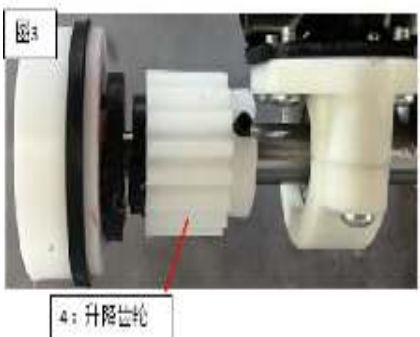

4: 升降齿轮

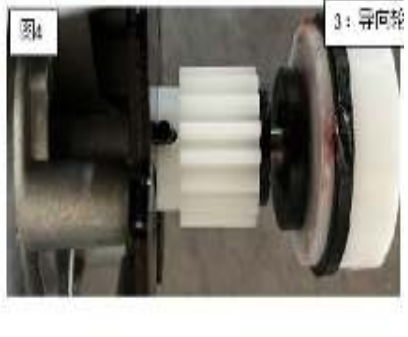

3: 升降轴

## 2.Removing the armrest assembly and shoulder part

### 2.1 Removing the armrest assembly

2.1.1 As shown in the figure below, turn off the entire machine. Then open the armrest to its maximum position, remove the M6\*30 hexagon socket head cap screws, unplug the connectors and air pipes between the armrest and the machine, lift upward firmly to separate the armrest from the machine, and remove the armrest assembly.

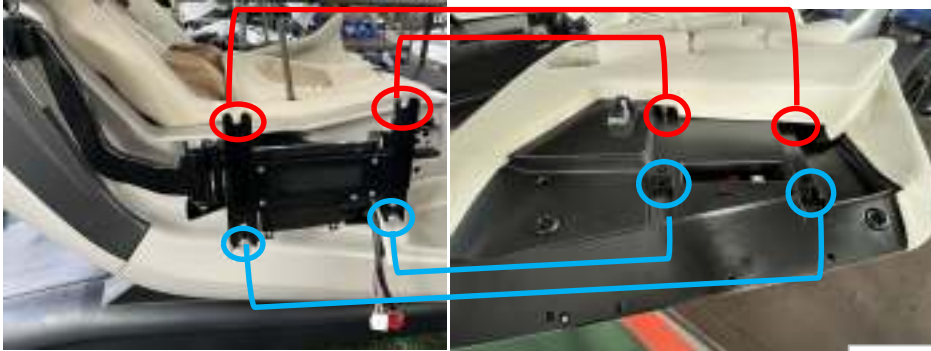

M6×30 hexagon socket head cap screw + φ6 flat washer

2.1.2 Removing the armrest assembly 2.1.2.1 As shown in the figure, use a tool to remove the 7 screws on the armrest plastic body (the armrest is connected by snaps at this time). Then firmly separate the inner and outer shells (be careful not to pull the wire harness), unplug the wire harness connector plug of the outer shell, and remove the outer shell.



2.1.3 Removing the upper armrest assembly 2.1.3.1 Disassembling the upper armrest assembly First, peel off the non-slip pad, then use a tool to remove the screws, firmly separate the clips, unplug the connector, then take off the upper armrest assembly and replace the internal components.



Left non-slip pad



2.1.3.2 As shown in the figure, disassemble and replace the internal components of the armrest according to the problem location.



2.1.3.2.1 When the armrest is properly locked after closing, the white light should be on normally. If the red light is on but the armrest remains locked, it is necessary to adjust the internal part of the armrest: slightly move the armrest lock limit switch (toggle the paddle outward; if the issue is the opposite, move it inward).

2.1.3.2.2 If the armrest lock fails to fasten securely (the armrest opens when pulled slightly): Shorten the length of the door lock connecting rod by turning the length adjustment nut of the door lock connecting rod to make the rod shorter.

2.1.3.2.3 When closing the armrest, if the armrest pops open directly: It is necessary to lengthen the length of the door lock connecting rod (turn the length adjustment nut of the door lock connecting rod to make the rod longer).

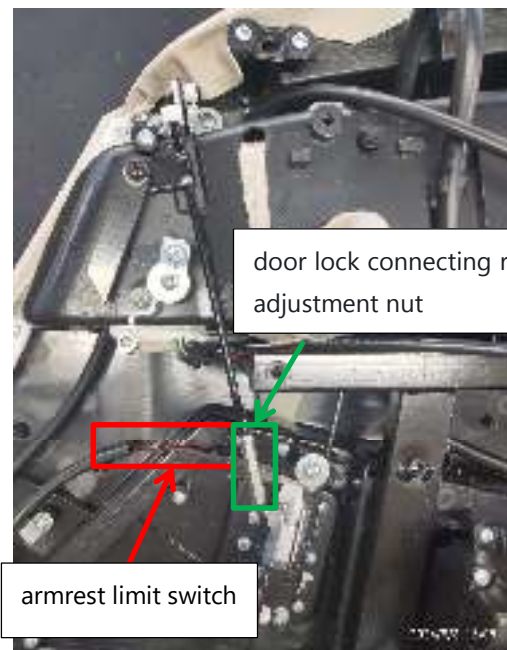

2.1.4 Removing the armrest shell partial assembly and light strip 2.1.4.1 Remove the screws fixing the inner and outer shells according to the previous procedure, take out the armrest outer shell, use a power tool to remove the screws fixing the upper and lower shell assembly of the armrest, and then replace the upper and lower armrest shells and the armrest light strip as needed.

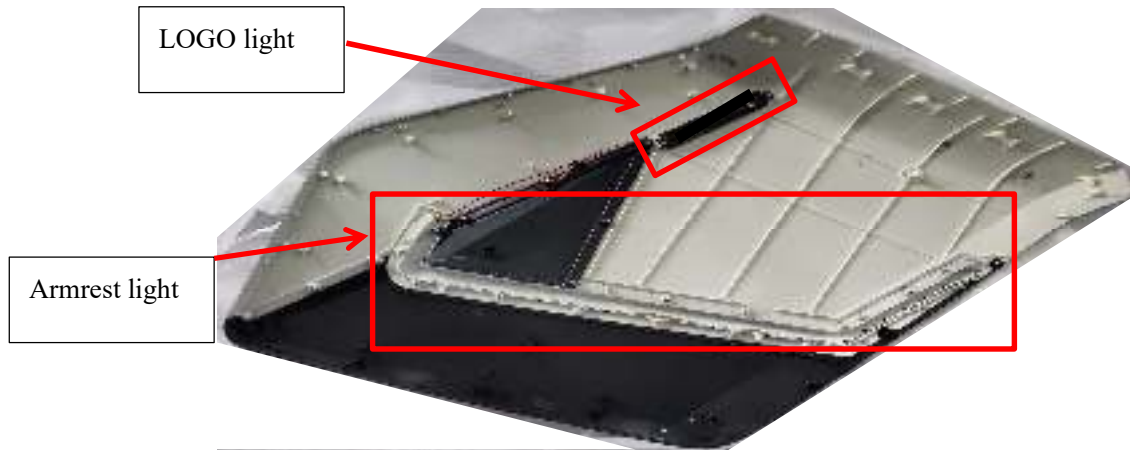

2.1.5 Removing the physiological detection assembly Use a tool to remove the screws, unplug the connector, then take down the physiological detection assembly for replacement.

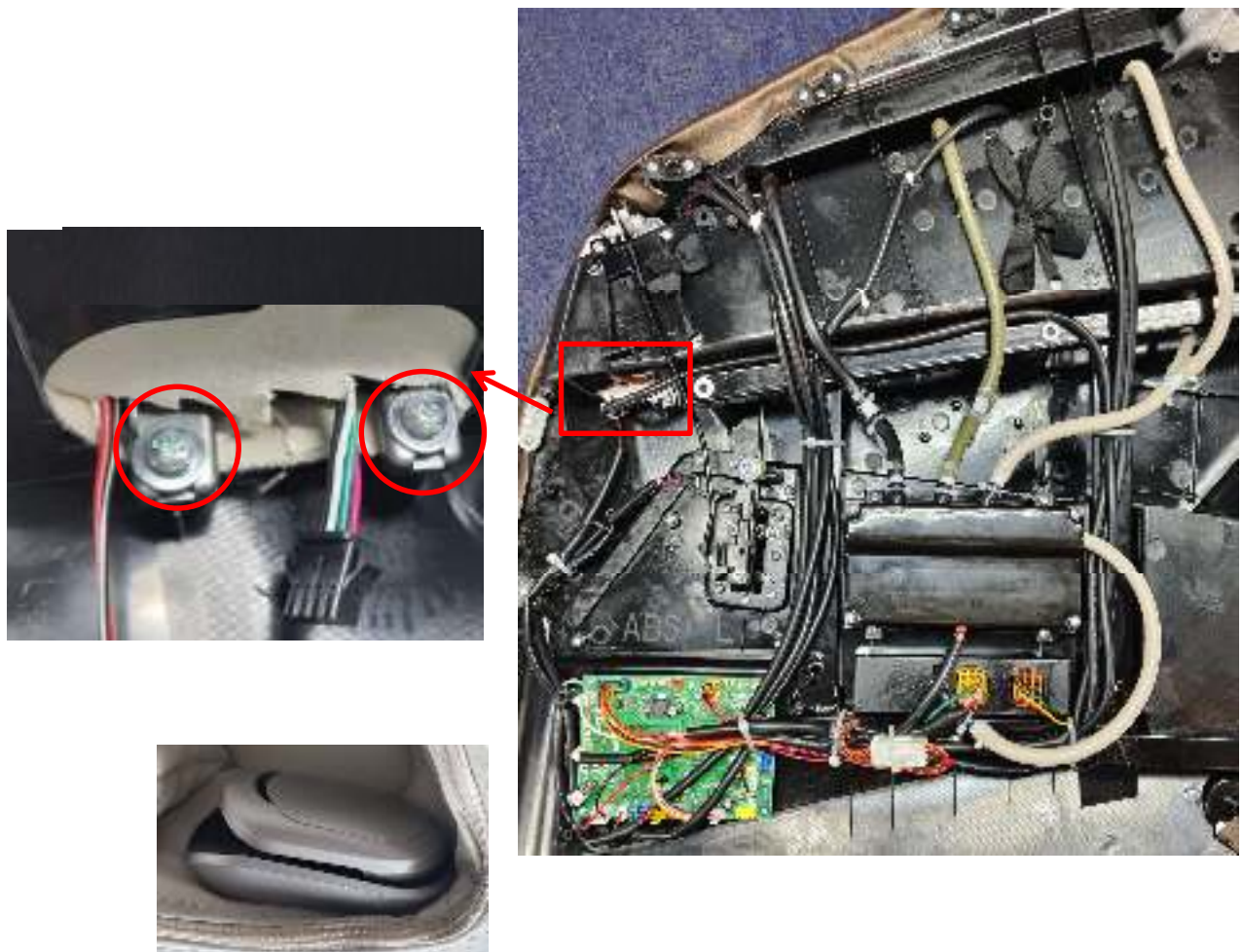

2.1.6 Replacing the armrest solenoid valve assembly 1. Remove the 4 screws fixing the solenoid valve assembly, then disconnect the connecting wire harness and air pipe. 2. Remove the 4 screws on the solenoid valve cover to expose the solenoid valve, then remove the 4 screws fixing the solenoid valve and replace the solenoid valve.

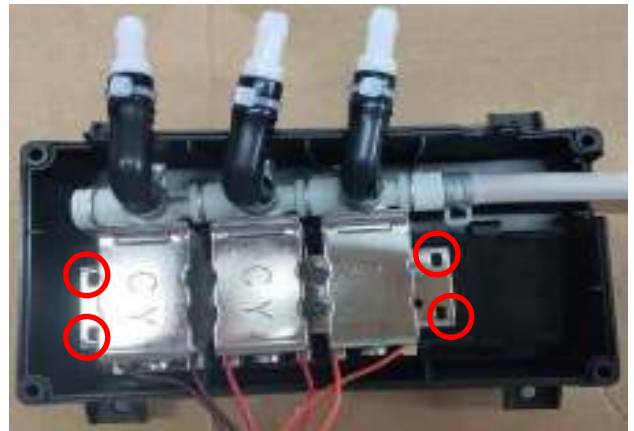

## 2.2 Removing the shoulder assembly

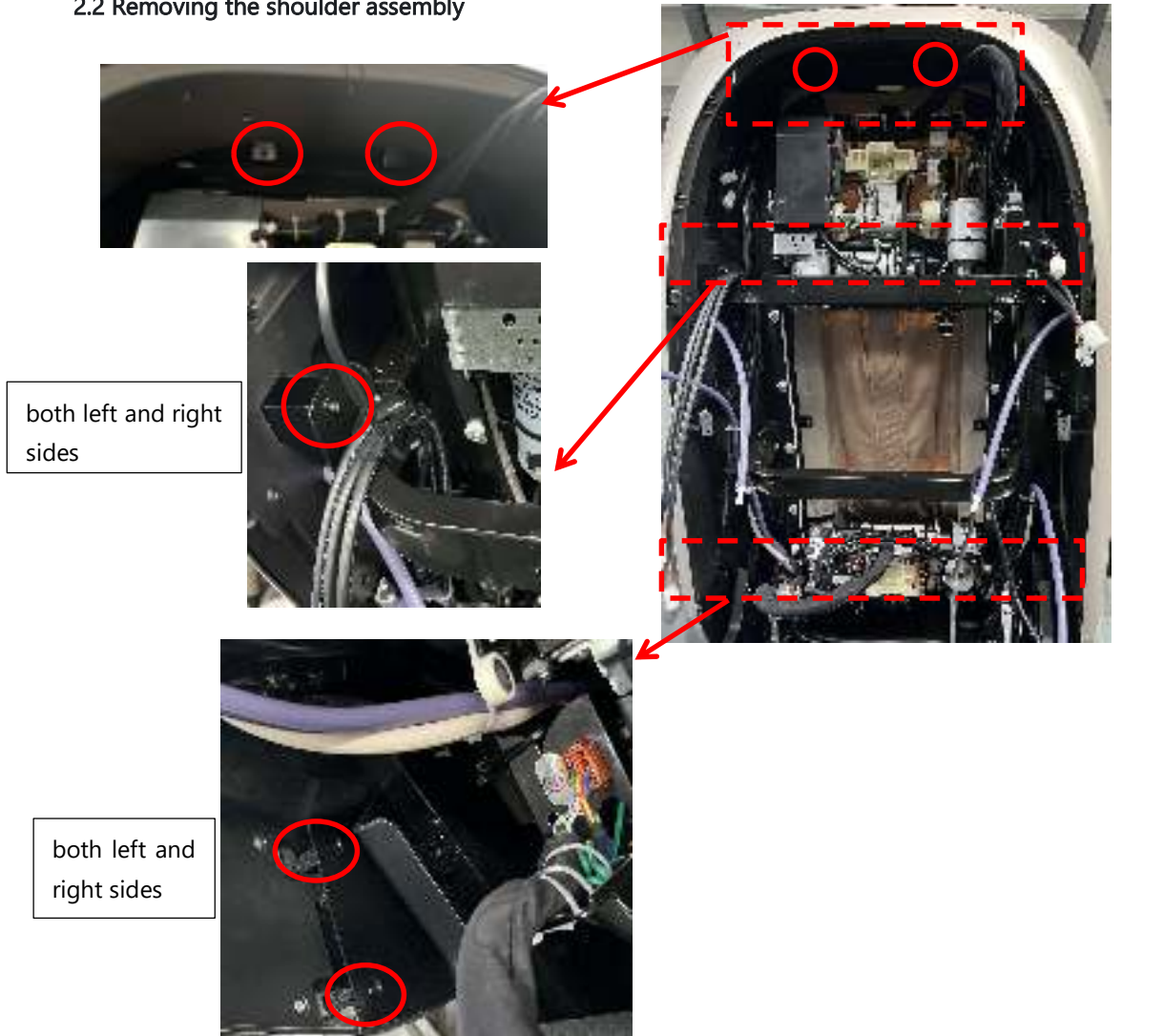

As shown in the above figure, first remove the rear shield of the backrest. Then, remove a total of 10 screws located at the top of the shoulder assembly, the upper parts of both sides of the shoulder, the joint of the shoulder decorative parts, and the front end of the backrest (below the airbag). After that, unplug the connecting air pipes and plug-in connectors, and replace the shoulder assembly.



## 2.2.1 Removing the shoulder assembly

When assembling the inner and outer shoulder assemblies: There are 5 fixing points under the shoulder airbag, 1 fixing point under the anion/aroma cover, and 2 fixing points under the speaker cover (a total of 39 fixing points).

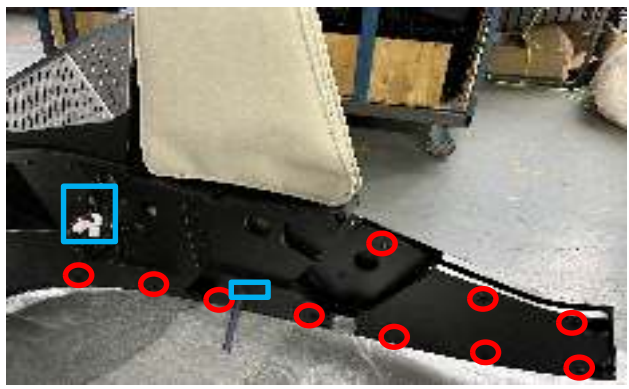
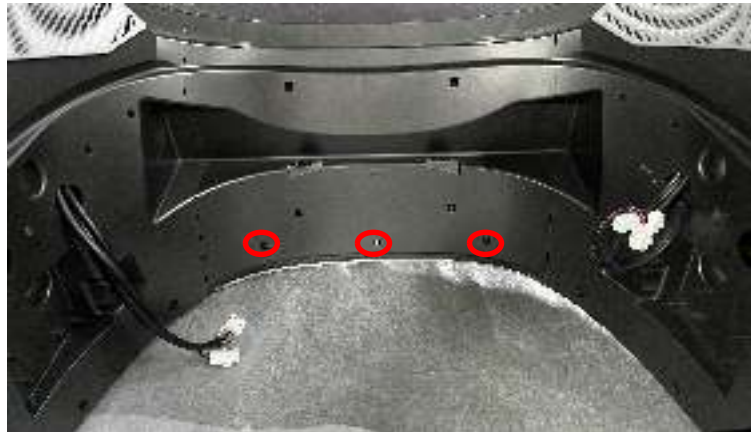

As shown in the above figure: Use a tool to remove the 39 screws, separate the inner and outer shells of the shoulder, then take off the shoulder outer shell and replace all internal component assemblies.

## 2.2.2 Replacing the rear light strip assembly of the shoulder

2.2.2.1 As shown in Figure 1: First, use a tool to remove the 6 screws, then unplug the wire harness connector and detach the shoulder light strip assembly.

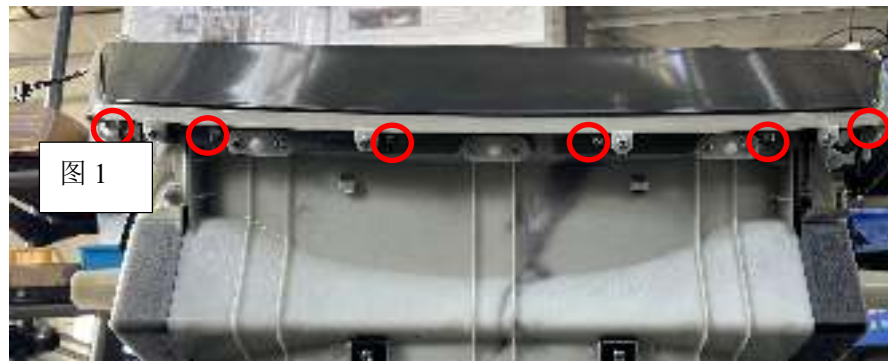

2.2.2.2 As shown in Figures 2/3: Use a tool to remove the 6 screws on the light strip assembly, take out the light bar assembly, and replace the light bar.



2.2.3 Removing the shoulder airbag As shown in the figure: First, unzip the sewn product. Then remove the screws under the shoulder airbag pouch, take the shoulder airbag out of the pouch to expose the PP board. After that, disconnect the air pipe connected to the airbag and replace the shoulder airbag. (Note: Hold the air pipe during replacement to prevent it from retracting into the PP board and getting lost.)



2.2.4 Replacing the rear left and right light strip assemblies of the shoulder As shown in the figure: Use a tool to remove the screws, detach the light bar fixing assembly, and then replace the light strip.

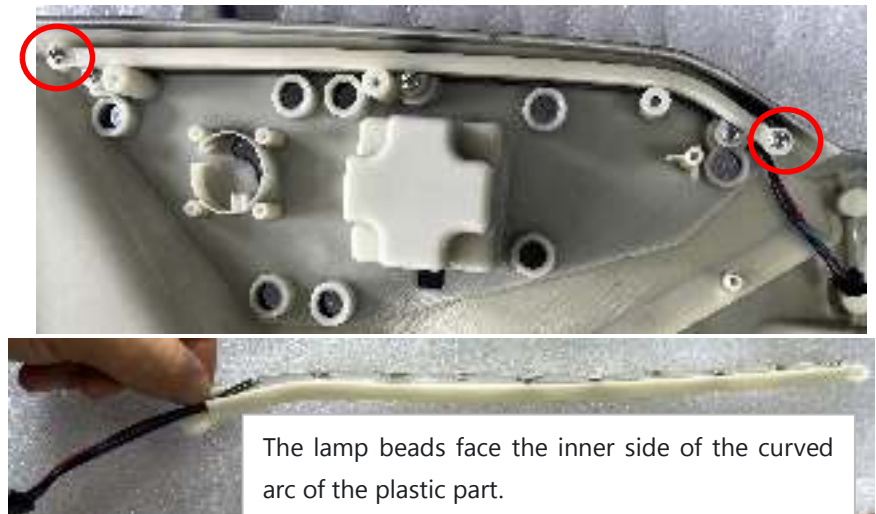

2.2.5 Removing the Shoulder Negative Ion Generator and Fan As shown in the figure, remove the

screws fixing the negative ion generator assembly, unplug the wire harness, and replace the negative ion generator assembly. Then, remove the screws fixing the fan, unplug the wire harness and the connecting air pipe, and replace the fan.

Left Shoulder Anion Generator/Fan



The air pipe must be placed here; otherwise, it may easily get crushed.

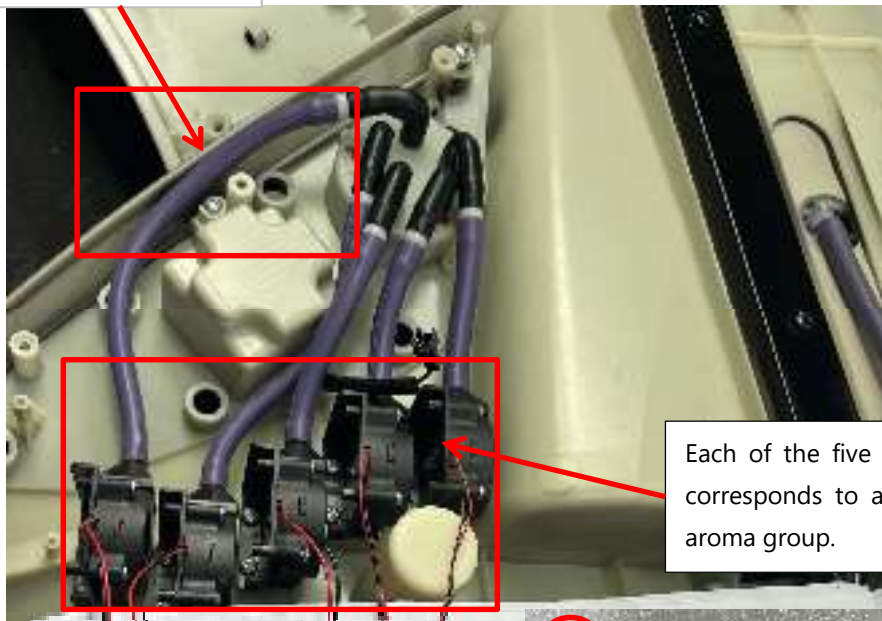

Each of the five fan groups corresponds to a respective aroma group.



3. Removing the front backrest plastic body assembly As shown in the figure, after removing the rear shield, remove the 4 screws on the left and right sides and the 2 screws at the front end according to the indicated positions. Then unplug the air pipes of the front seat side of the backrest and the lumbar airbag, and replace the front backrest plastic body assembly.

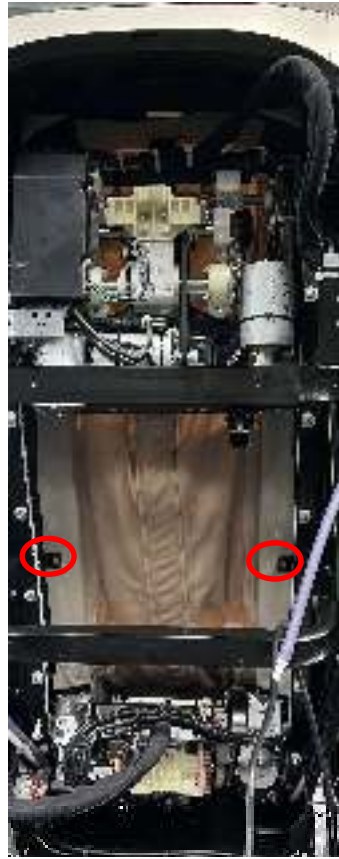

#### 4. Removing the power box assembly

4.1 As shown in the figure:

4.1.1 Use a tool to remove the 3 screws on the power box cover, then remove the upper cover of the power box by shaking it left and right.

4.1.2 Depending on the maintenance situation, disassemble the screws of each component and replace the components that need to be replaced. After removing the screws marked with red circles in the figure, unplug the plug-in connector and the air pump air pipe, and then the entire power box assembly can be replaced.

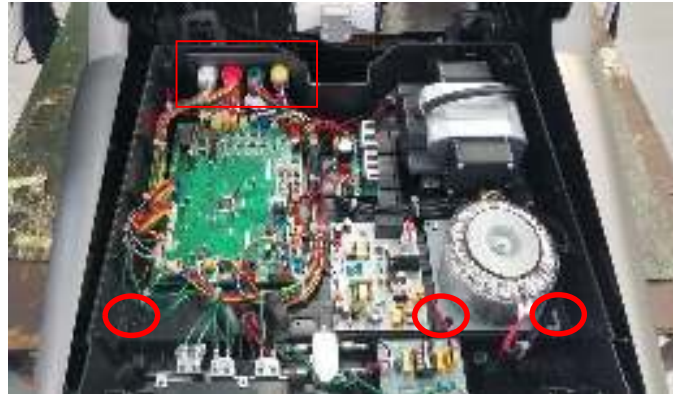

5. Removing the leg and foot section As shown in the right figure: First, lift the leg and foot assembly to unplug the connector and air pipe. Then use a tool to remove the 2 screws connecting the leg and foot section, and replace the leg and foot assembly.



5.1 Removing the foot assembly 5.1.1 As shown in the figure below: Use a tool to remove the screws at the indicated positions, then take off the rear shield of the leg and foot section to replace the shield components and repair the internal structure.



5.2 Replacing the foot assembly and solenoid valve 5.2.1 As shown in the figure below: First, use a screwdriver to remove the screws at the indicated positions, then unplug the wire harness and air pipe in sequence, and replace the foot assembly and solenoid valve assembly.

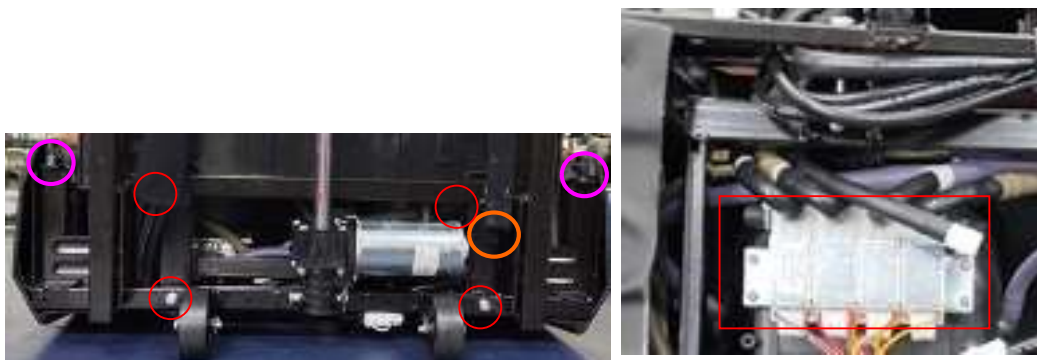

5.3 Replacing the leg and foot telescopic support rod 5.3.1 As shown in the figure: Use a tool to remove the 2 M6\*12 screws, then take out the pine leaf pin + B8\*40 pin shaft. Unplug the connecting wire harness connector afterward and replace the leg and foot telescopic support rod assembly.

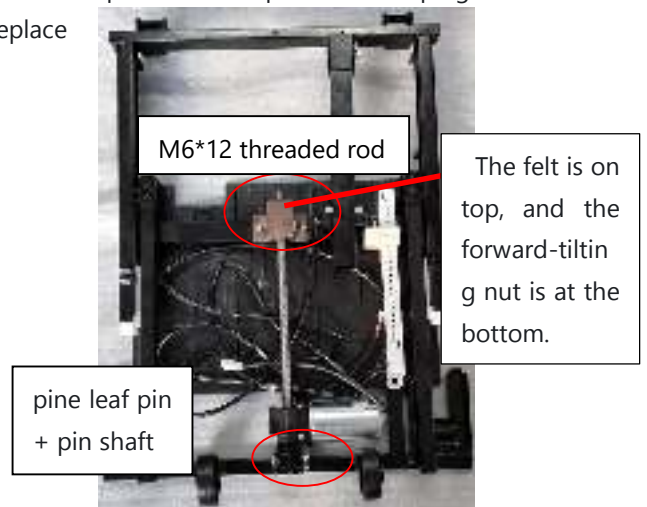

5.4 Removing the leg frame 5.4.1 As shown in the figure below: First, unzip the sewn product, then remove the airbag and take it out of the fabric cover of the sewn product. After that, remove the screws at the indicated positions and replace the leg frame and leg massage assembly.

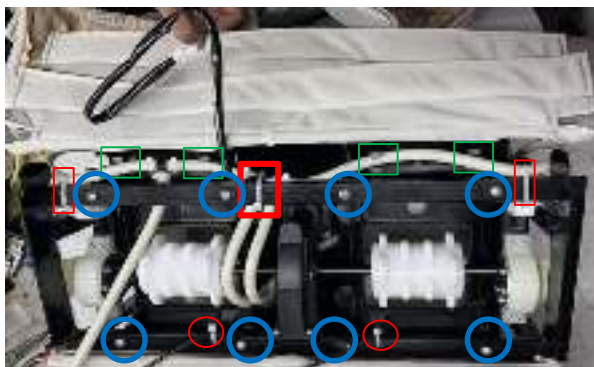

Remove all connecting screws and bundled wire harnesses and air pipes.



Sewn products and leg plastic body assembly

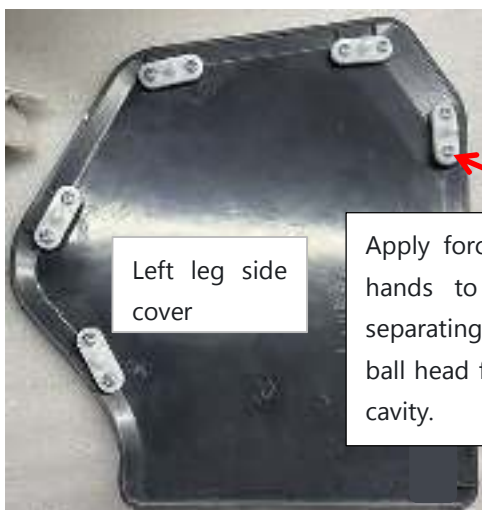

Left leg side cover

Apply force with both hands to pull apart, separating the buckle ball head from the ball cavity.



Remove the connecting screws.

5.4.2 Removing the leg massage assembly  
Remove the screws and connectors at the indicated positions, then replace the leg massage assembly.

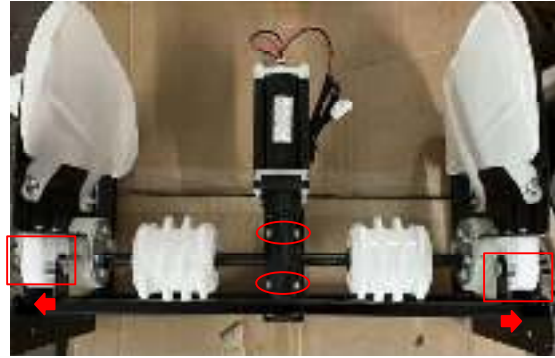

5.5 Removing the foot roller  
As shown in the figure: Use a tool to remove the screws at the indicated positions, unplug the wire harness connector, then remove the foot massage assembly and replace the foot roller massage assembly.

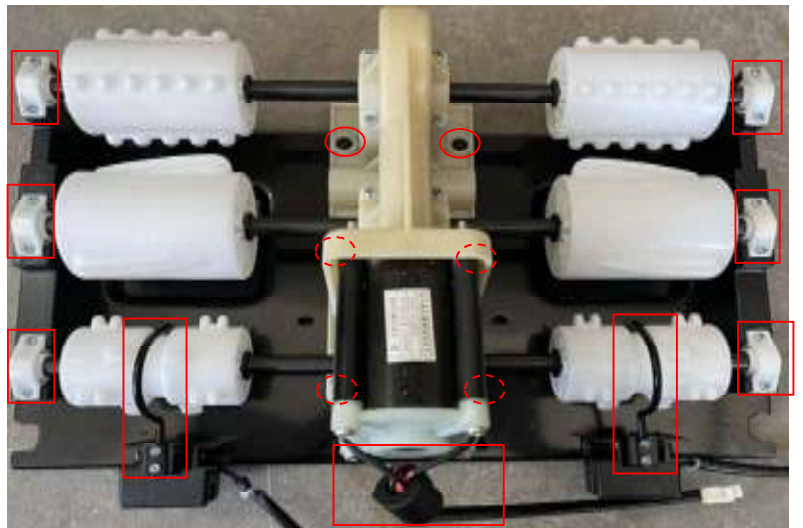
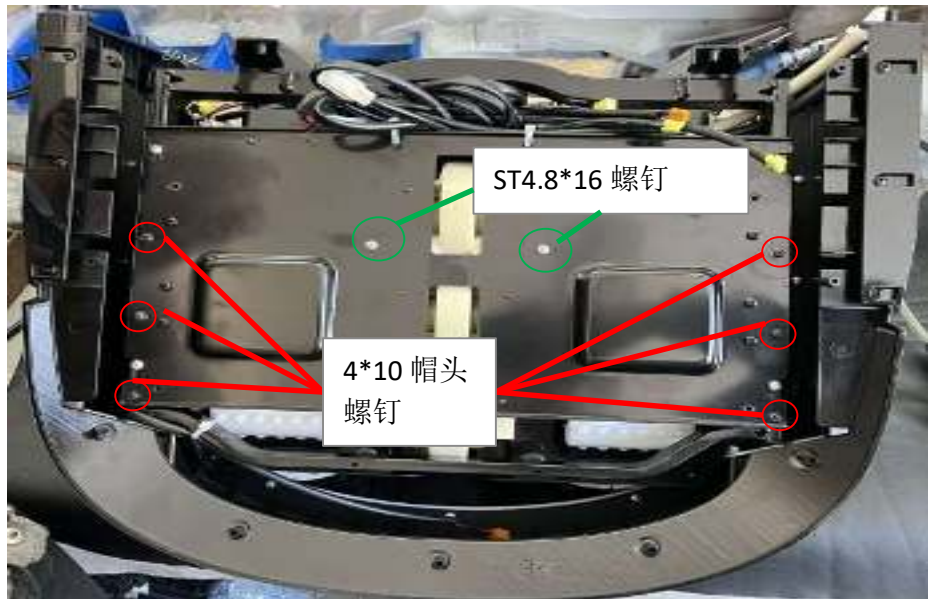

5.6 Replacing the foot anti-pinch and solenoid valve assembly Remove the upper and lower shells of the foot according to the indicated positions, then take off and replace the foot anti-pinch detection board.



5.7 Replacing the foot light strip assembly As shown in the figure: Remove the screws at each indicated position and replace the foot light strip assembly.

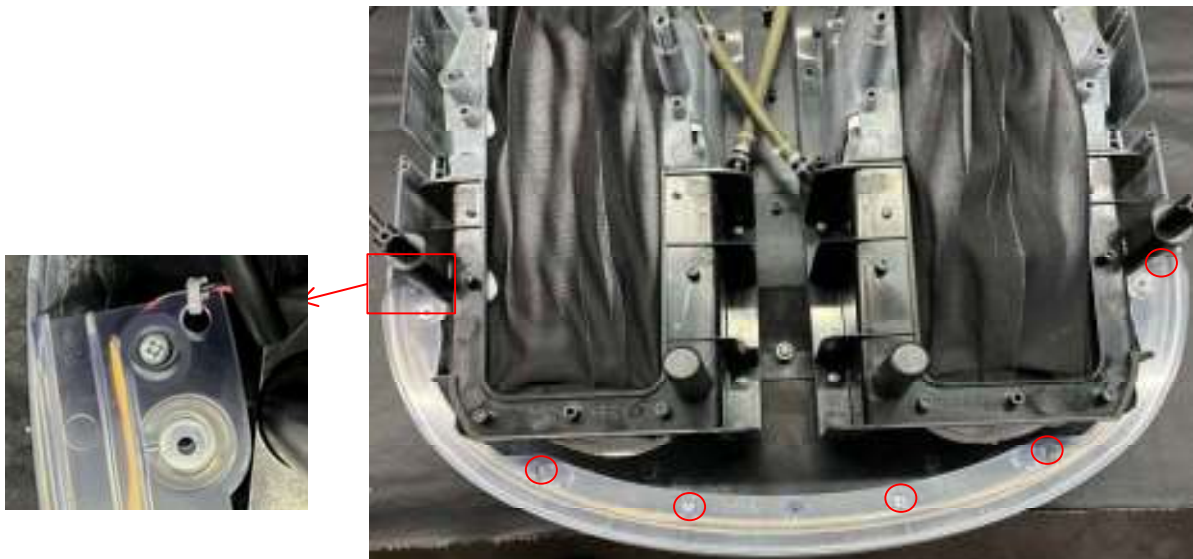

## 6.Removing the backrest support rod and leg-foot support rod assembly

6.1 Removing the backrest support rod assembly Simple method: After removing the leg-foot assembly (follow step 5 above to remove the leg-foot assembly), lay the massage chair on its side. From the exposed area at the bottom of the massage chair, remove the anti-loosening pine leaf pin from the end of the support rod with the motor, then take out the pin shaft and remove one end of the support rod. For the other end, use an M6 hexagon socket wrench to remove the four screws fixing the support rod, take out the flat push rod fixing plate assembly, disconnect the connecting wire harness, and replace the backrest assembly support rod.

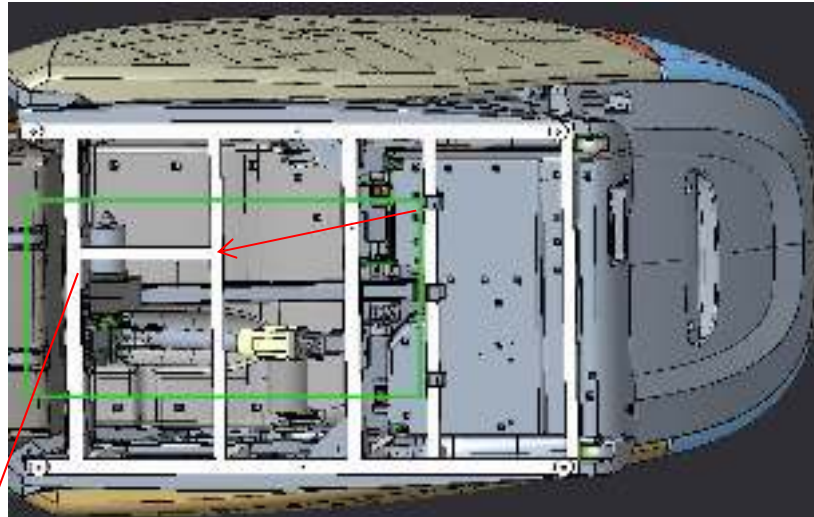

6.2 Removing the leg-foot support rod assembly From the exposed area at the bottom of the massage chair, first remove the anti-loosening pine leaf pin from the end of the support rod with the motor, then take out the pin shaft and remove one end of the support rod. Place the massage chair upright afterward, remove the pine leaf pin and pin shaft from the front, disconnect the connecting wire harness, and replace the leg-foot assembly support rod.

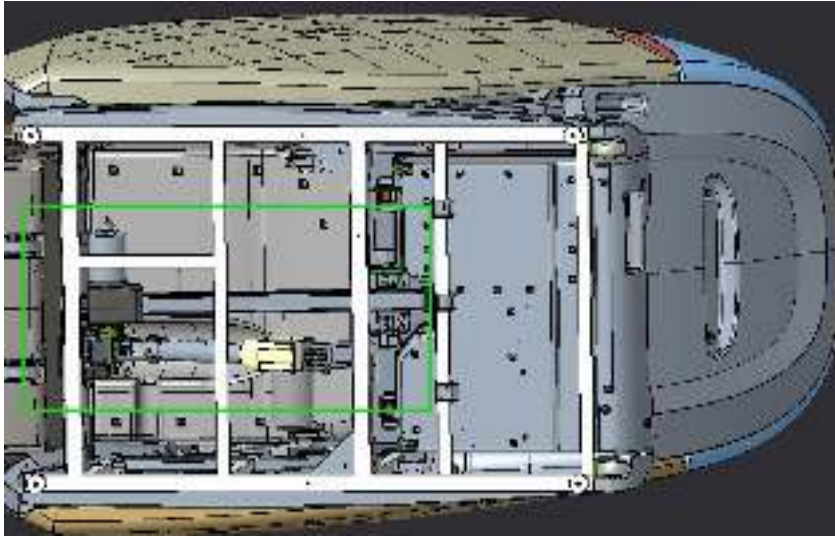

## 7.Removing the backrest frame solenoid valve assembly

7.1 Remove the armrest assembly according to step 2.1.

7.2 Remove the left and right lower guard plate assemblies.

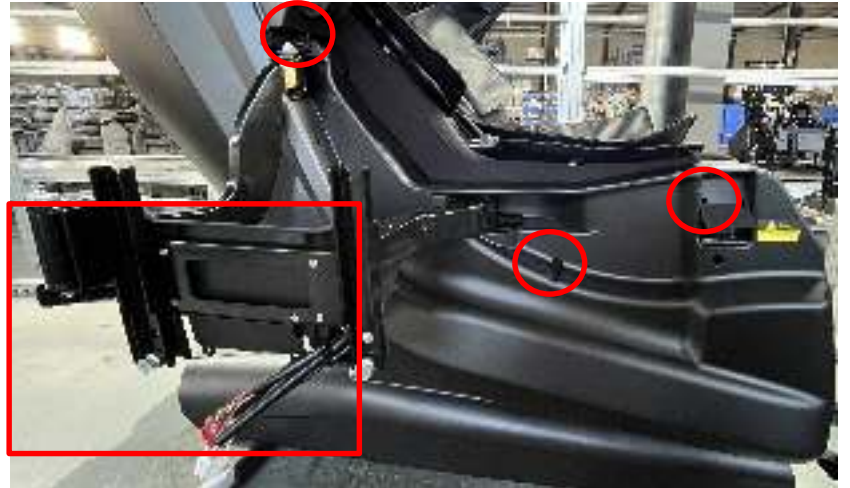

7.2.1 As shown in the right figure: First, move the connecting rod assembly to the rearmost position (maximum door opening position). Use a tool to remove the 3 screws on the lower guard plate assembly, then rotate and reposition the lower guard plate to expose the solenoid valve on the backrest frame assembly and replace the solenoid valve assembly.



7.2.2 Unplug the wire harness and air pipe connected to the solenoid valve, use a tool to remove the 4 screws fixing the solenoid valve, and replace the solenoid valve.

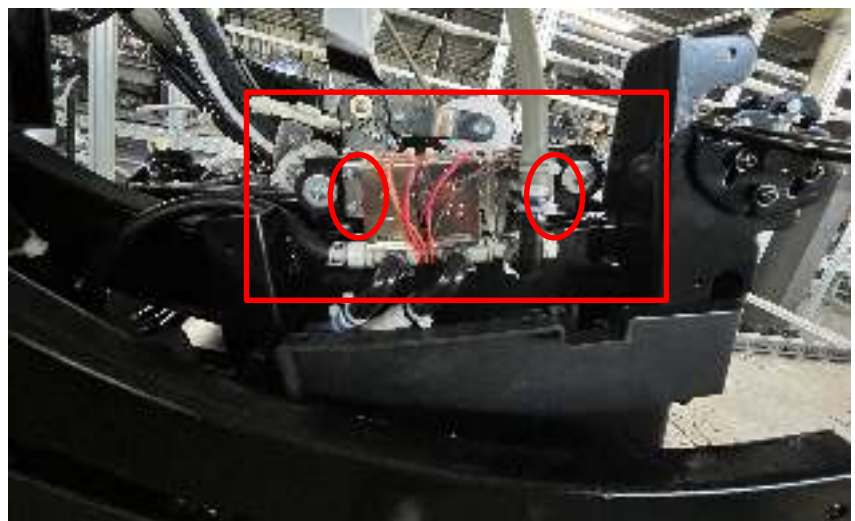

## 8.Adjusting the gap between the armrest assembly and the shoulder

8.1 First, remove the armrest assembly according to step 2.1.1.

8.2 Rotate the connecting rod frame assembly to the position closest to the inner side of the massage chair, remove the screws fixing the lock adjustment plate, then use a wrench to firmly turn the pin shaft on the lock adjustment plate to achieve the optimal gap between the armrest assembly and the shoulder.

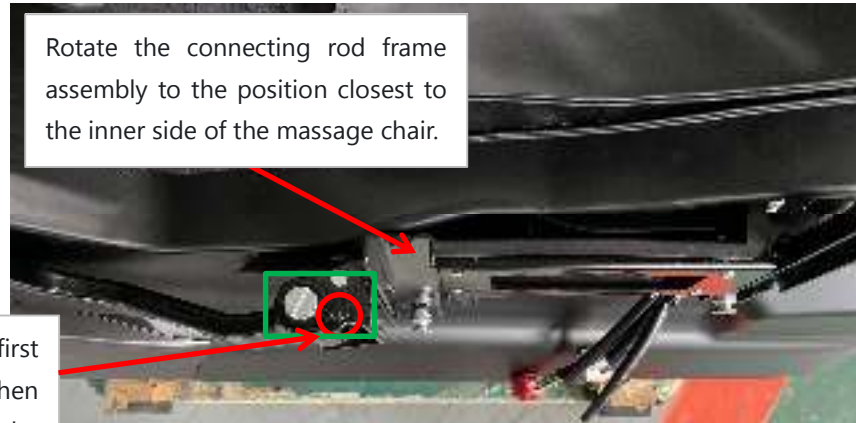

When adjusting the gap, first remove the screws here, and then fasten them securely after the adjustment is completed.

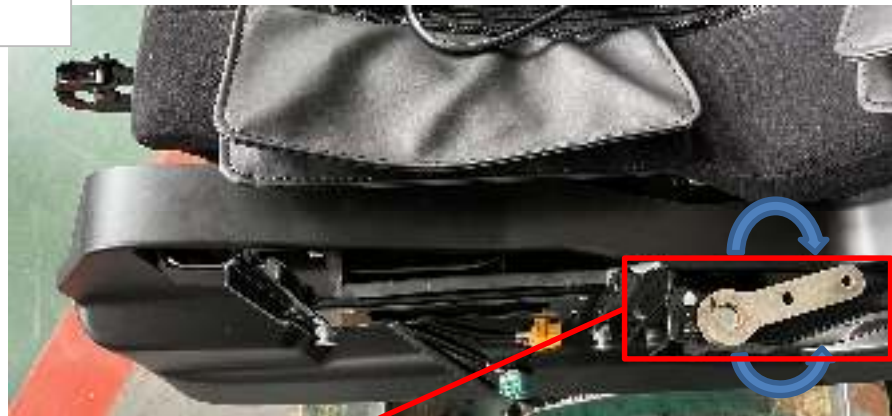

Or use a flathead screwdriver to turn the slotted position above the pin shaft.

Use a wrench to turn the pin shaft counterclockwise/clockwise to adjust the gap between the armrest and the shoulder.

## 8.Repairing the Massage Mech Assembly

8.1 As shown in Figure 1 below: Use a tool to remove the screws fixing the lower frame connecting plate, then remove the lower frame assembly.

8.2 As shown in Figure 2: Use a tool to remove the screws fixing the upper frame connecting plate, unplug all connectors, separate all wire harnesses, and then separate the massage mechanism from the overall frame.

Figure1

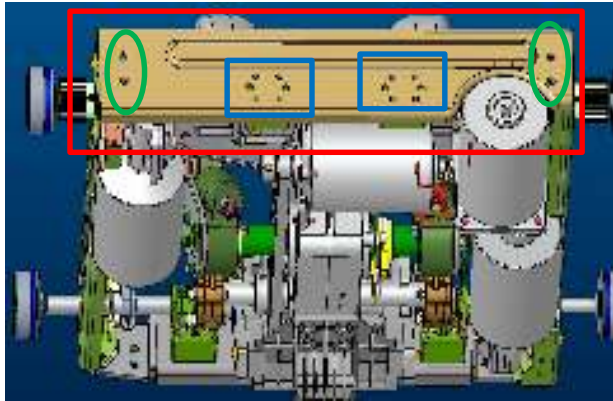
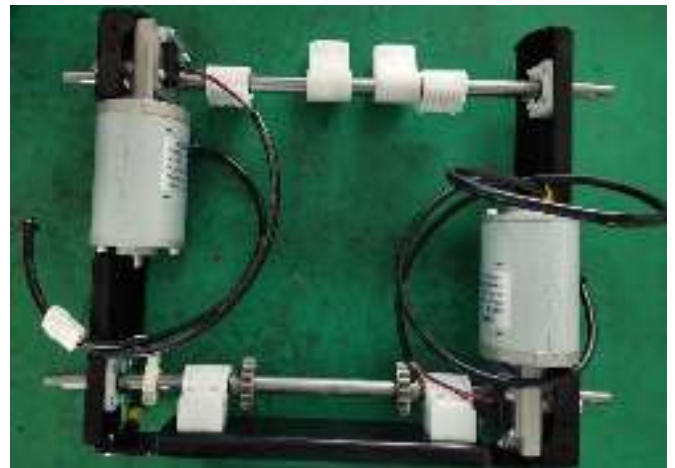
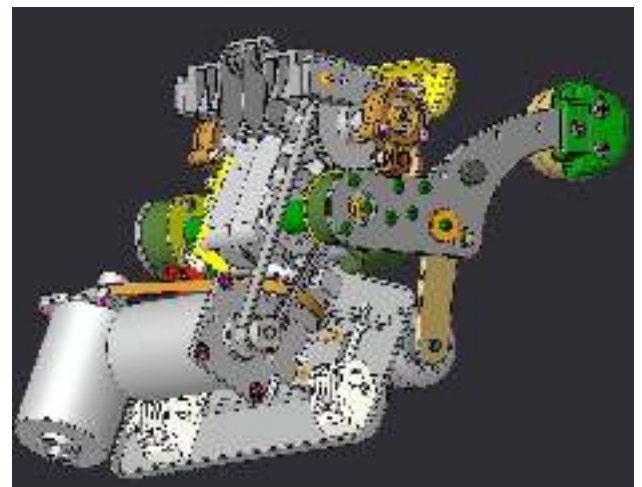
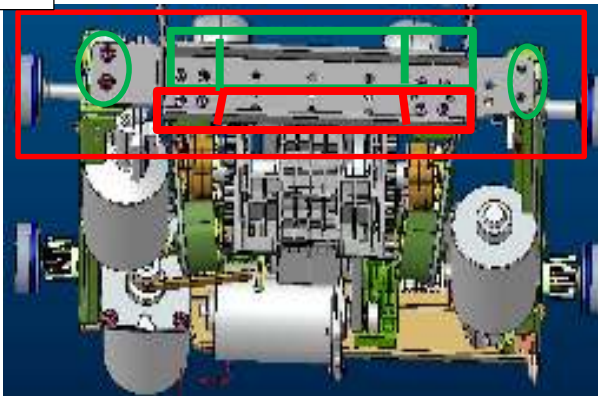
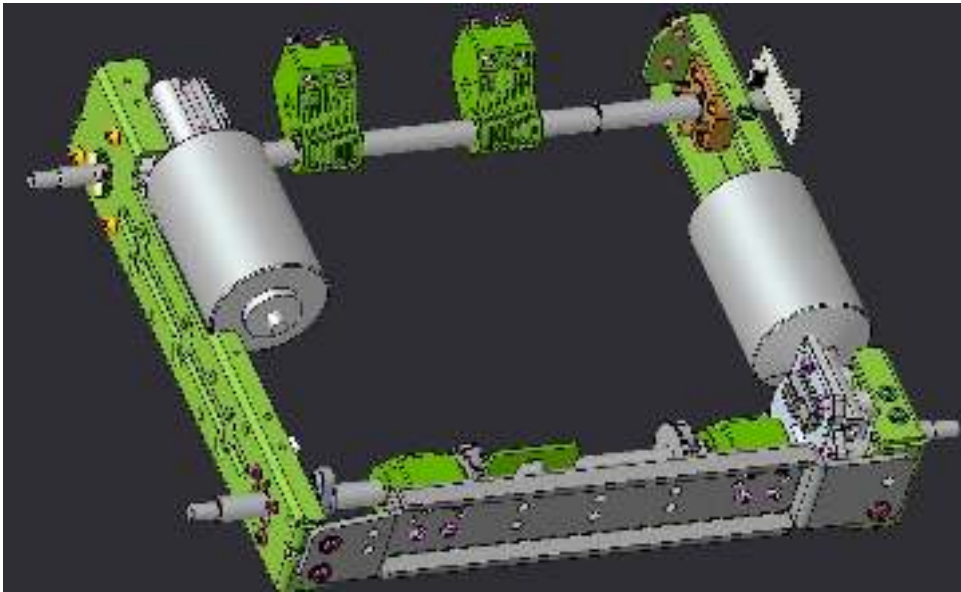

Figure2



### 8.3 Replacing the lifting and tilting motor assembly



8.3.1 As shown in the above figure: First, connect the electrical test fixture to the lifting and tilting motor with power to test the motor sound. If there is abnormal noise when the motor rotates, replace the motor shaft assembly.

8.3.2 Remove the fixing screws at each position according to the above figure, take out the lifting shaft assembly and tilting shaft assembly for replacement.

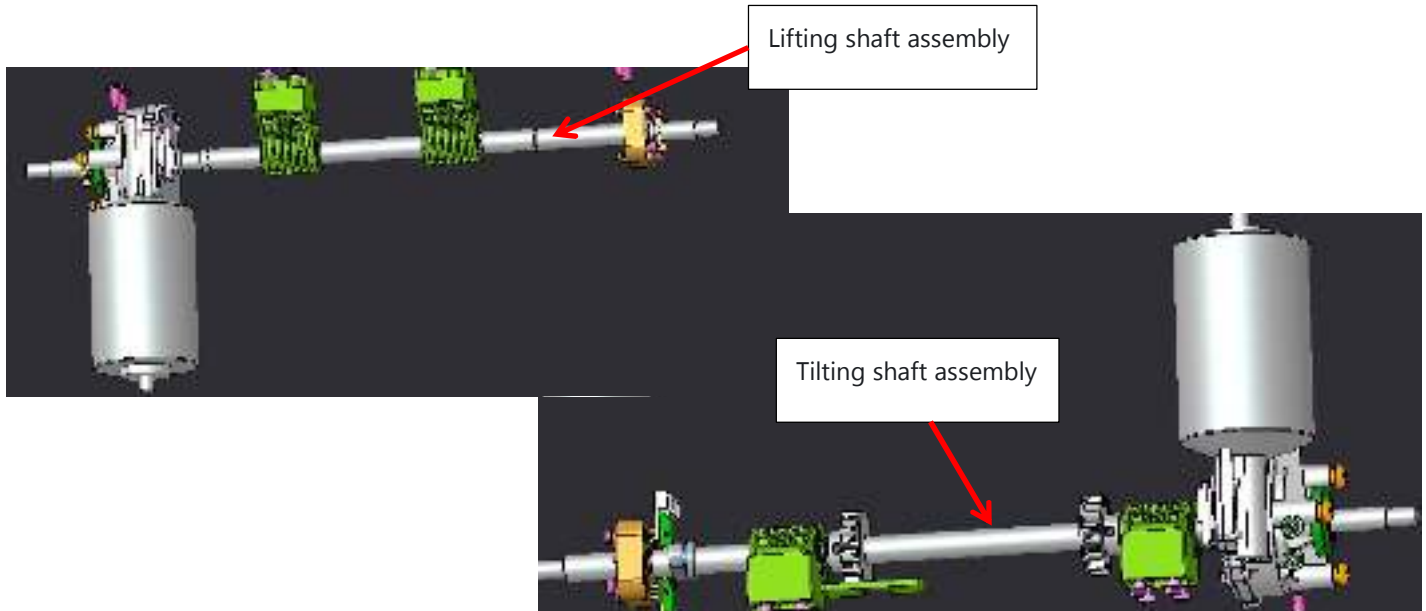

#### 8.4 Replacing the kneading and tapping motor assembly.

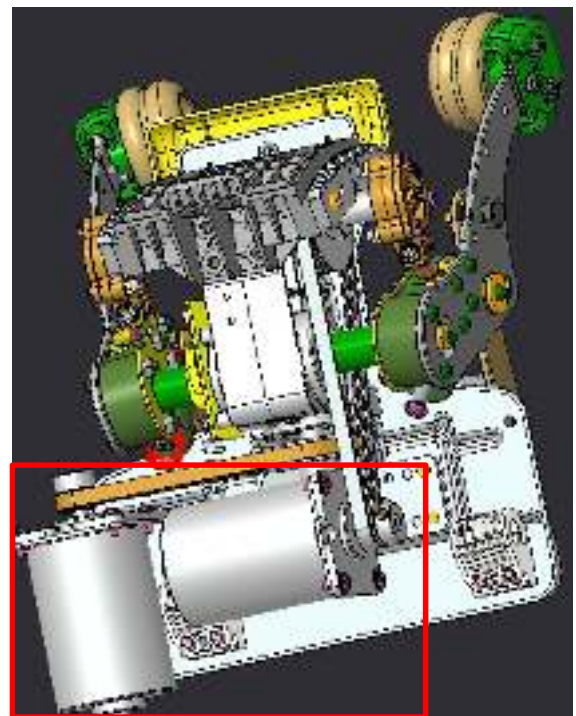
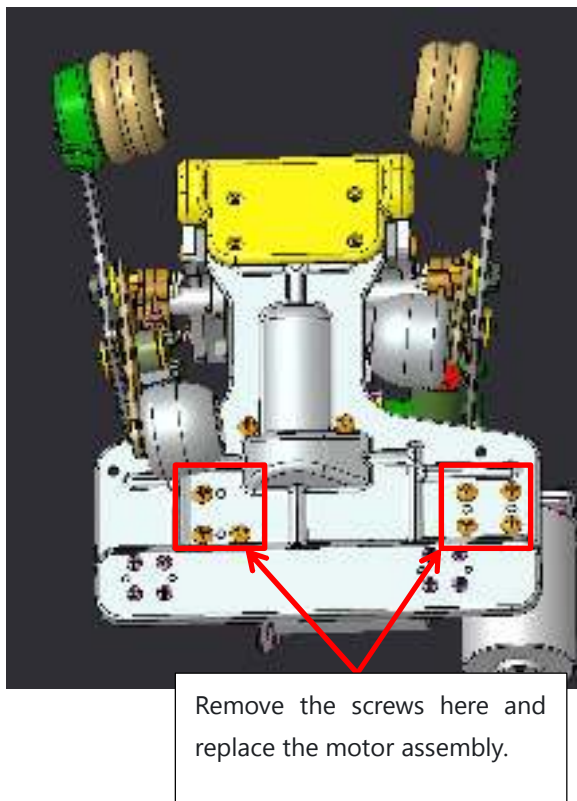

8.4.1 As shown in the figure: First, remove the pulley from the motor. Use an electrical test fixture to power on and test if there is abnormal noise when the motor rotates. If there is abnormal noise during no-load rotation, disconnect the wire harness and connectors, then use a tool to remove the screws fixing the kneading and tapping motor, and replace the motor assembly.

## 8.5 Replacing the rocker arm assembly

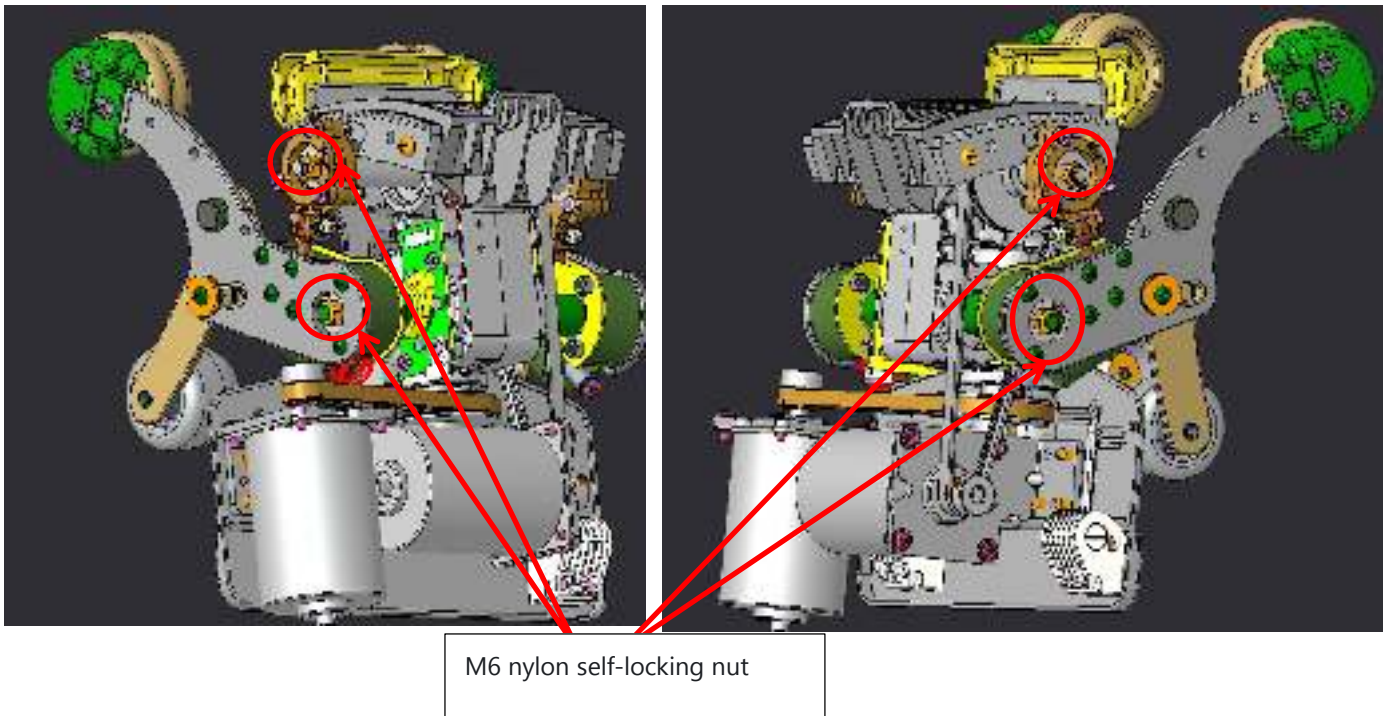

Use a tool to remove the M6 nylon self-locking nuts that fix the left and right rocker arm assemblies, then replace the left and right rocker arm assemblies. (Since anaerobic adhesive is applied to the shaft threads when fixing the nuts, a strong tool is required for removal. When re-fixing, anaerobic adhesive must be reapplied to prevent issues such as the rocker arm falling off, loosening, or causing abnormal noise during operation.)



### 9.Replacing the Air Pump Assembly

9.1 Use a tool to remove the 3 screws fixing the power box cover, then take off the power box cover assembly.

9.2 Removing the air pump assembly inside the power box

9.2.1 Use a tool to remove the 4 screws fixing the air pump, use pliers to open the air pipe clamp and pull out the air pipe, disconnect the wire harness connected to the air pump, take out the air pump assembly inside the power box, and replace it with a new air pump assembly.

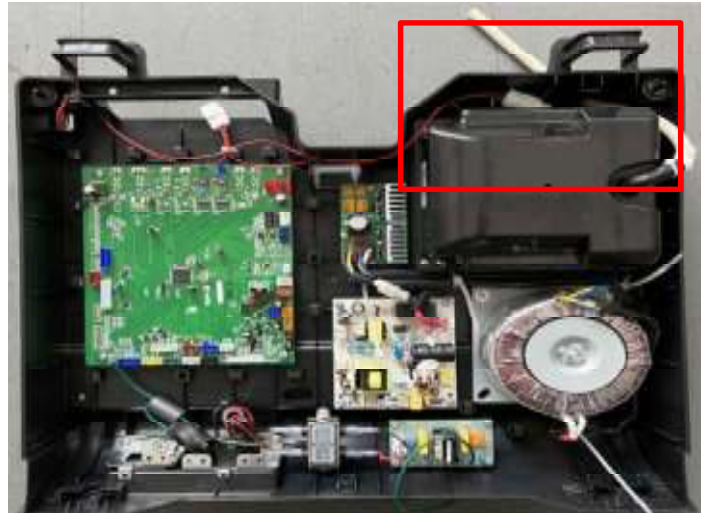

### 9.3 Removing the Under-Seat Air Pump Assembly

9.3.1 First, remove the power box cover according to Process 9.1, then remove the 3 fixing screws inside the power box, disconnect the connector, and remove the power box assembly by shaking it left and right.

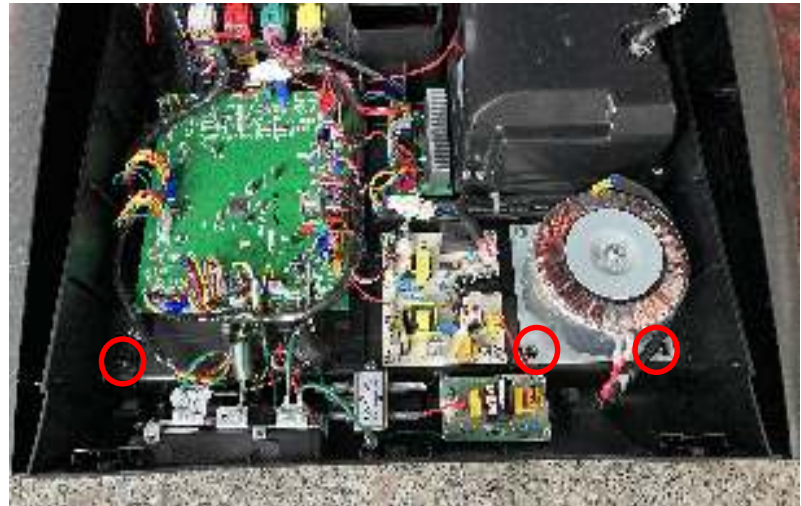

9.3.2 As shown in the figure below: Use a tool to remove the 9 screws fixing the side baffle, take off the left side baffle assembly to expose the air pump assembly on the bottom frame, disconnect the air pump connector and connecting wire harness, remove the 4 fixing screws and air pipe of the air pump, and replace the air pump assembly on the bottom frame.



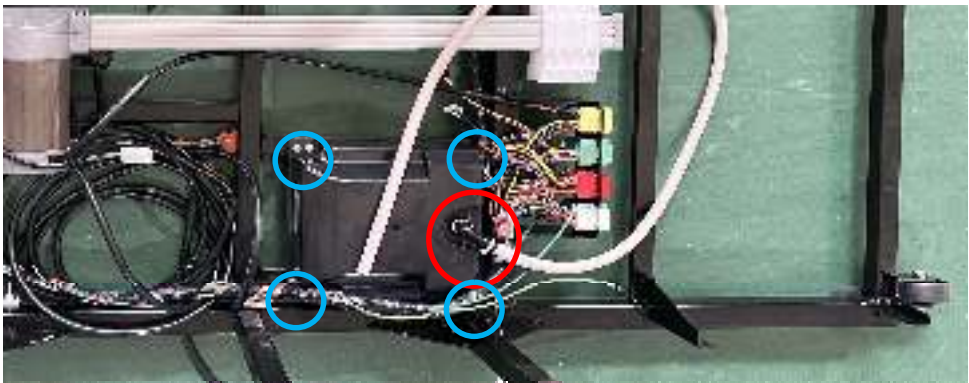



Armrest panel (refer to the corresponding ports in the left and right armrest electrical diagrams above)

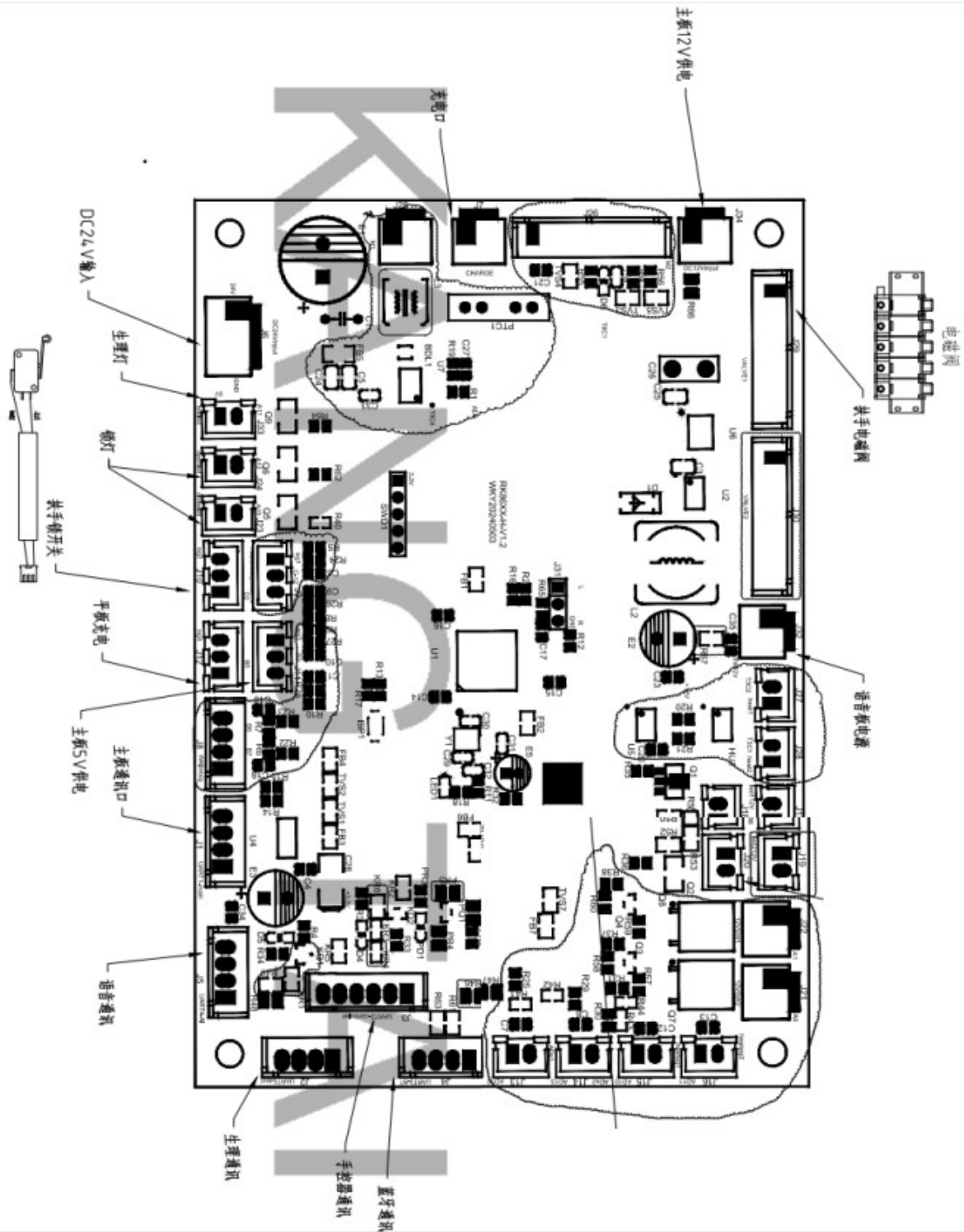

Foot and leg board

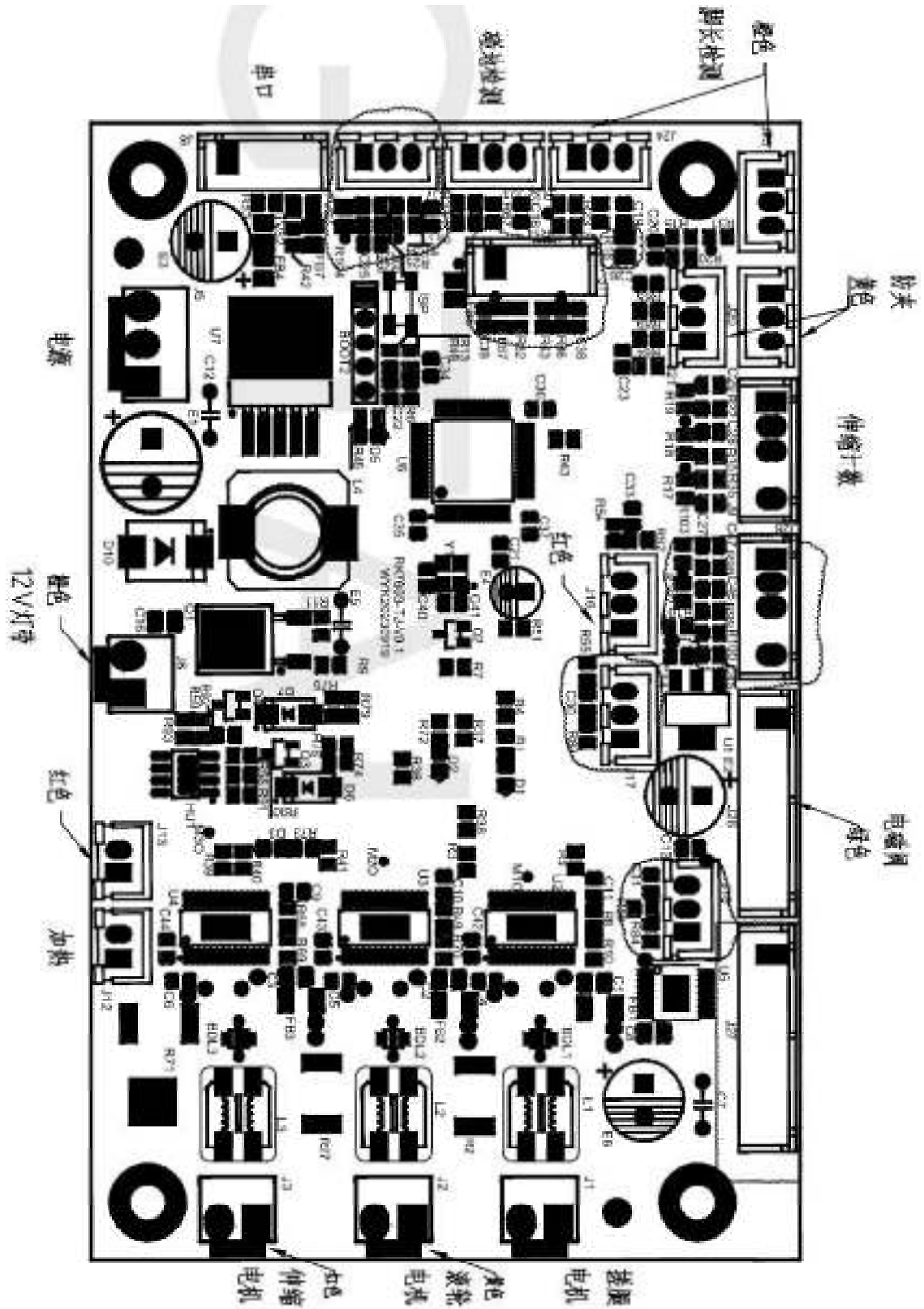

# Upper Mech Board

