

# **ZIVA/ TELOS**

## **(RK2003B) Service**

### **Manual**



# Outline

## I. Structure Component

1. RK2003B Chart.....	1
2. Key Parts .....	3
<b>II. Common Failure &amp; Troubleshooting .....</b>	
<b>4</b>	
1. The whole chair doesn't work, no display on the remote control. ....	5
2. Loudspeaker problem.....	6
3. <a href="#">Actuator problem</a> .....	7
4. Foot rollers problem .....	8
5. Air pressure function problem .....	9
6. Massage mech up-down function problem .....	11
7. Massage mech shoulder detection problem.....	13
8. Massage mech kneading functin problem .....	14
9. Massage mech tapping functin problem.....	14
10. Massage mech width adjustment problem(wide, medium and narrow) .....	15
11. Waist heat problem .....	16
12. <a href="#">Remote control screen is abnormal while the button functions are normal.</a> .....	16

---

13. Quick remote control problem .....	16
<b>III. Mechanical Failure &amp; Troubleshooting</b> .....	<b>18</b>
1. Disassemble the legrest assy. ....	18
2. Disassemble the backrest cover.....	18
3. Disassemble the armrest assy .....	19
4. Disassemble massage mech assy .....	20
5. Disassemble power box, air pump.....	21
6. Disassemble magnetic valves assy .....	22
7. Change actuator.....	23
<b>IV. Main PCB Components Layout</b> .....	<b>25</b>
<b>V. System Connection Diagram</b> .....	<b>26</b>

# I. Structure Component

## 1.RK2003B Chart

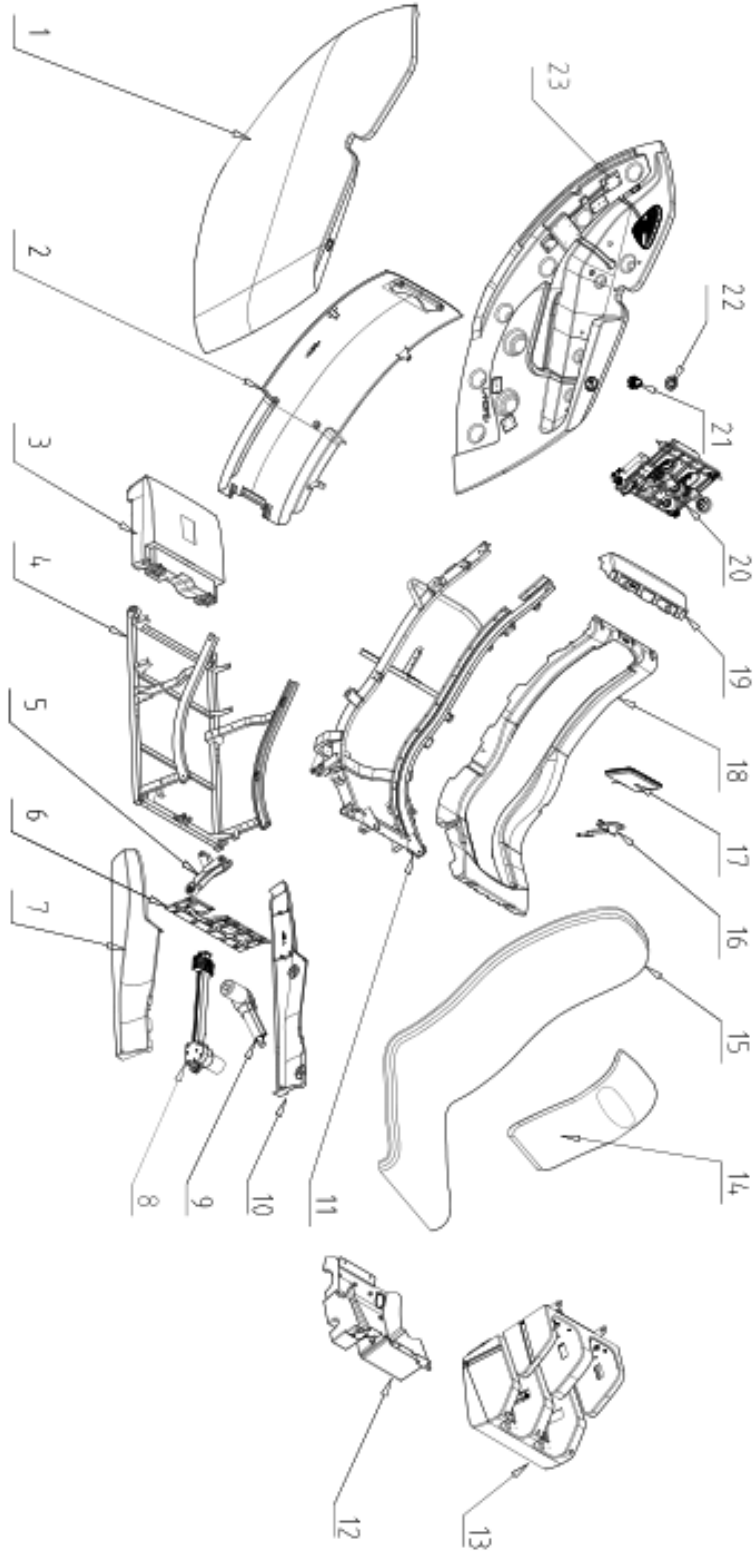

## Component List

SN	Name	Qty	SN	Name	Qty
1	Right Armrest	1	22	Knob Cover	1
2	Back Cover	1	23	Left Armrest	1
3	Power Box Assy	1			
4	Seat Frame	1			
5	Legrest Link	1			
6	Front Baffle	1			
7	Right Baffle	1			
8	Back Actuator	1			
9	Leg Actuator	1			
10	Left Baffle	1			
11	Back frame	1			
12	Lower Back Cover	1			
13	Legrest Assy	1			
14	Head Cushion	1			
15	Back Cushion	1			
16	Tablet Bracket Assy	1			
17	Controller	1			
18	Lower Backrest Plastic Parts	1			
19	Upper Backrest Plastic Parts	1			
20	Massage Mech	1			
21	Knob	1			

## 2. Key Parts



**Main PCB**

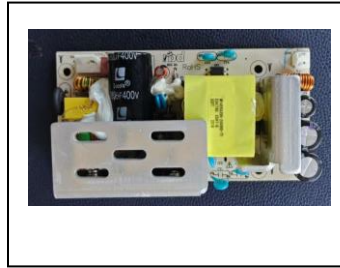

**Power Board**



**Controller**



**Switch**



**Air Pump**



**Massage Mech**

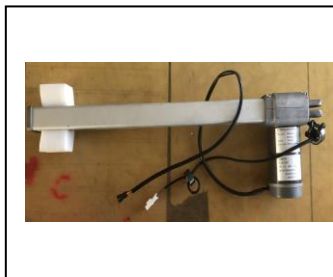

**Back Actuator**

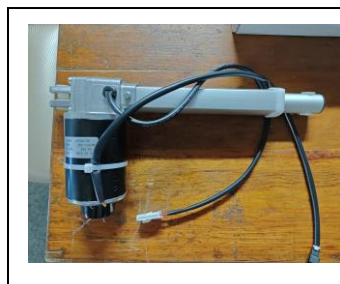

**Leg Actuator**



**Bluetooth Board**



**Knob Controller**

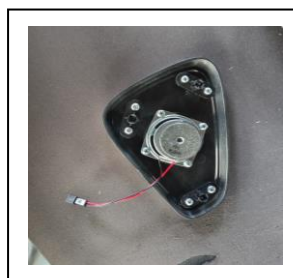

**Loudspeaker**

## II. Common Failure & Troubleshooting

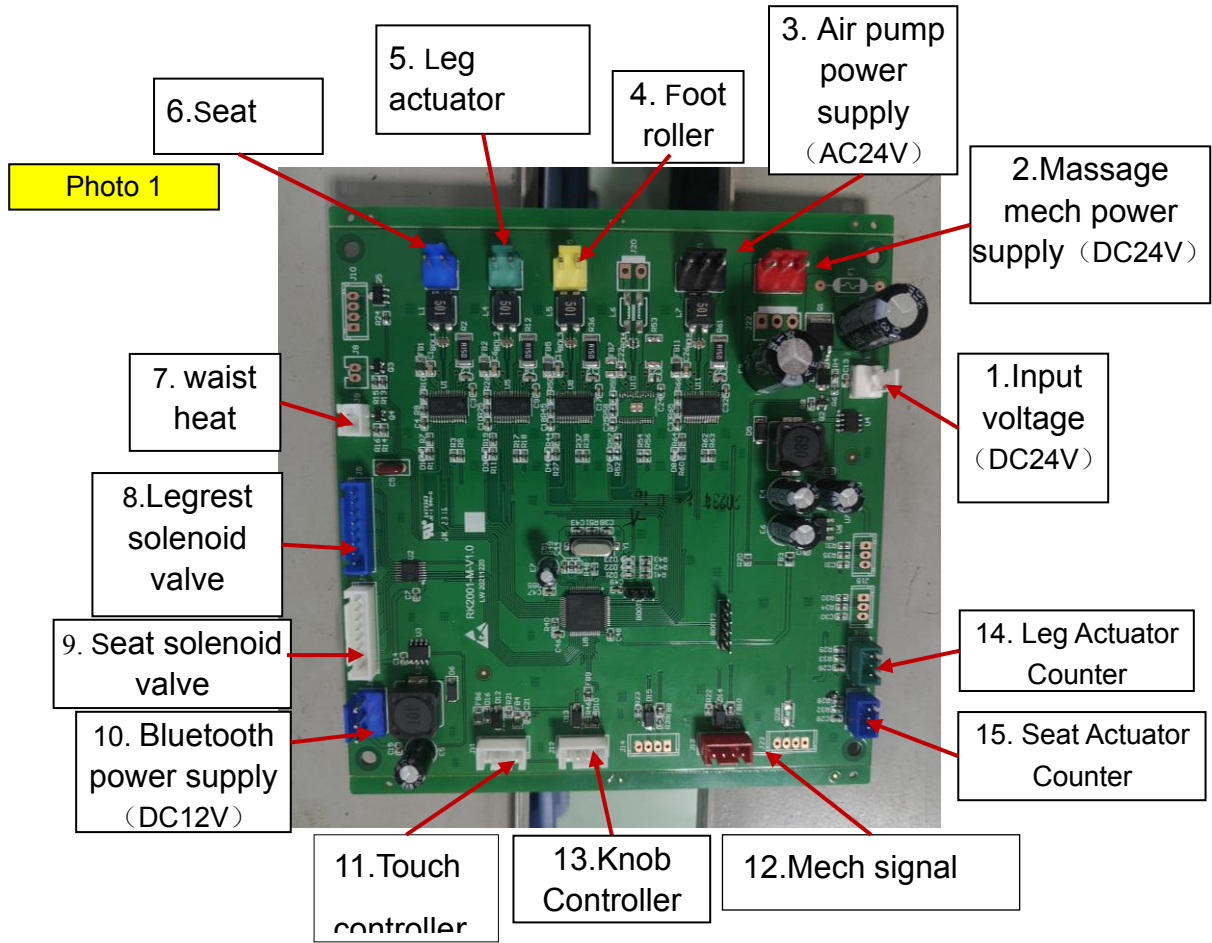
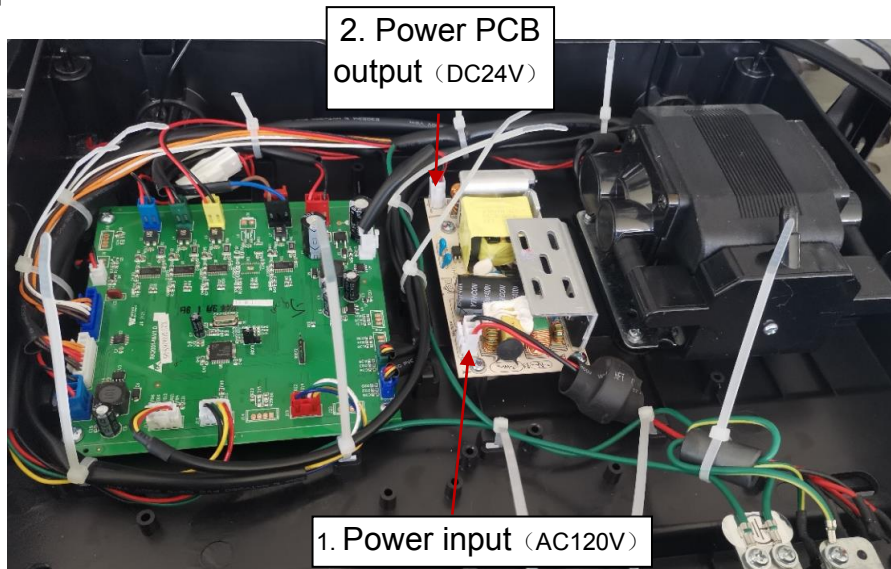

Photo 2

### Connection Diagram



### Power Box Connecting Chart

**1.The whole massage chair doesn't work and the remote control doesn't display.**

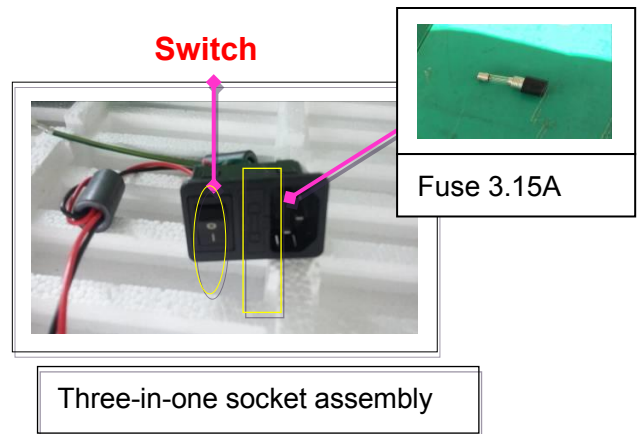

1.1 First check that the socket has power and the three-in-one switch is turned on, determine whether the fuse of the three-in-one switch is burned out. If the fuse is burned out, replace it.

1.2 Use the AC voltage range of a multimeter to measure the voltage at 1 switching power supply board connector and 2 locations in Figure 2. If there is AC120V voltage at 1 location and no DC24V voltage output at 2 locations, the switching power supply board is broken and just replace the switching power supply board; If there is voltage output, use the DC voltage range of a multimeter to measure whether the voltage at the mainboard connector (DC24V) in Figure 1 is normal. If there is no voltage, replace the connecting cable between the switching power supply board and the mainboard.

1.3 Check whether the hand control and the motherboard

connector are securely connected. If they are securely connected, measure whether there is DC5V voltage at both ends of connector 11 in Figure 1. If there is voltage, replace the hand control assembly. If there is no voltage, replace the main line. If the board is damaged, replace the master board.

**Abnormal situation: If the roller doesn't work and the support rod and air pressure control functions are normal, replace the main board.**

## 2. Loudspeaker problem.

2.1 Set the multimeter to the DC voltage range to measure whether the voltage 12V at both ends of connector 1 (1 negative, 3 positive) of the Bluetooth power amplifier board in Figure 3 is normal. If there is

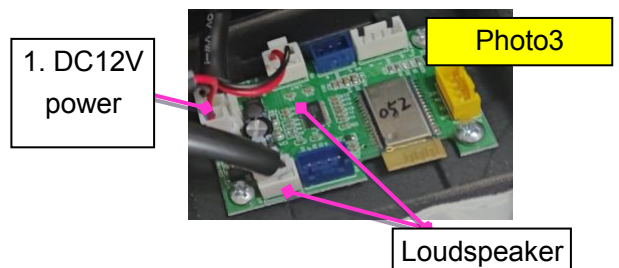

voltage on the Bluetooth power amplifier board, the red and blue LED lights flash, and the music still cannot be played normally. , the speaker is broken, just replace the speaker.

2.2 If there is no DC12V voltage on the Bluetooth power amplifier board, measure whether connector 10 on the motherboard in Figure 1 has a DC12V voltage output. If there is an output, replace the connection harness between the two circuit boards. If there is

no output, replace the main board.

### **3. Electric actuator problem.**

**3.1** Determine whether the main board is damaged or the electric actuator is damaged.

**3.1.1** Exchange the non-working electric actuator connector with another electric actuator connector(leading out from the main board). If it still does not work after the exchange, then it proves that the electric actuator is damaged. Replace it to eliminate the fault.

**3.1.2** The electric actuator can work after replacement, which proves that the main board is damaged. Replacing the main board can eliminate the fault.

**3.2** How to judge the quality of electric actuator.

**3.2.1** Set the multimeter to the DC voltage range, insert the two test leads into the connector terminal of the support rod, operate the backrest lifting button of the remote control to see if the multimeter has a 24V output. If so, the actuator is broken. If not, the main board is broken. Just replace it.

**3.2.2** If the electric actuator is at the upper limit or lower limit, use a multimeter to measure the diode position and measure the plug-in line. The value of the two lines of the strut is not measured interchangeably with the red and black test pens. If there is a measured diode one-way conduction value (about 0.5) , there is no problem with the actuator, otherwise the actuator is damaged. If the actuator is not at the two extreme positions, use electrical resistance measurement to check the plug-in line. If the resistance between the two lines of the strut has no resistance or is too large, it proves that the electric actuator motor has opened circuit (normally within  $5\Omega$  -around  $30\Omega$ ). The fault can be eliminated by replacing the electric actuator.

#### **4. Foot roller problem.**

4.1. Turn on the foot roller function, set the multimeter to the 200V DC voltage range, and use the two test leads to measure whether the voltage at 4 (yellow) in Figure 1 is DC24V. If the main board does not have a DC24V voltage output, the main board is broken. If there is voltage output, check whether the mating connector is securely connected. If there is no problem, it is usually because the roller motor is broken, replaced it.

## **5. Air pressure function problem.**

### **5.1 Air pump does not work.**

5.1.1 Check whether the air pump power cord and the main board connector (3 in Figure 1) are in good condition.

5.1.2 Use a multimeter to measure whether there is AC24V voltage at the main board connector (3 in Figure 1). If there is voltage, it means the air pump is broken and you can replace the air pump. If there is no voltage, the main board is broken and you can replace the main board.

### **5.2 The air pressure decreases after the air pump has been working for a while.**

5.2.1 Check whether the air pump air inlet is dirty or blocked, and clean the air pump air inlet.

5.2.2 Check whether the air pipe on the air pump is bent or loose. Fix or replace the air pipe.

### **5.3 The air pump works normally, but the air bag does not inflate**

Port corresponding sequence table (6 solenoid valves in total)

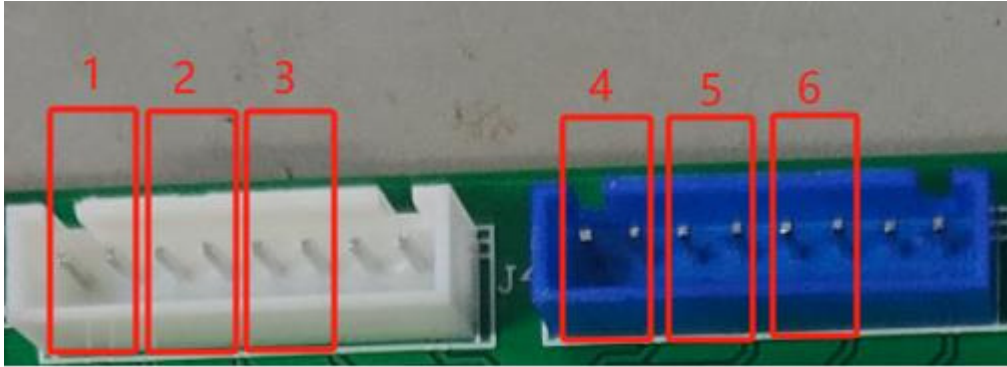

- |                                 |                    |
|---------------------------------|--------------------|
| 1. Left Arm Airbag              | 4. Leg Side Airbag |
| 2. Right Arm Airbag             | 5. Calf Airbag     |
| 3. Left & Right Shoulder Airbag | 6. Foot Airbag     |

5.3.1 Check if there is any detachment or looseness in the air pipes of the air pump and solenoid valve, and re insert and fix them;

5.3.2 Check if there is an open circuit in the solenoid valve drive part corresponding to the non inflatable airbag, and if the components are damaged (as shown in the above figure). If so, replace the master board.

5.3.3 Check if the solenoid valve is damaged.

Inspection method: Place the multimeter in the resistance mode and measure whether there is a resistance value (around 165  $\Omega$ ) displayed. If the resistance value is infinite or small, it indicates that the solenoid valve is faulty and can be replaced.

5.3.4 Check if there is a DC24V voltage input at the solenoid valve port on the master board. If not, it indicates that the master

board is damaged and can be replaced.

## 6. Massage Mech Up-down Problem

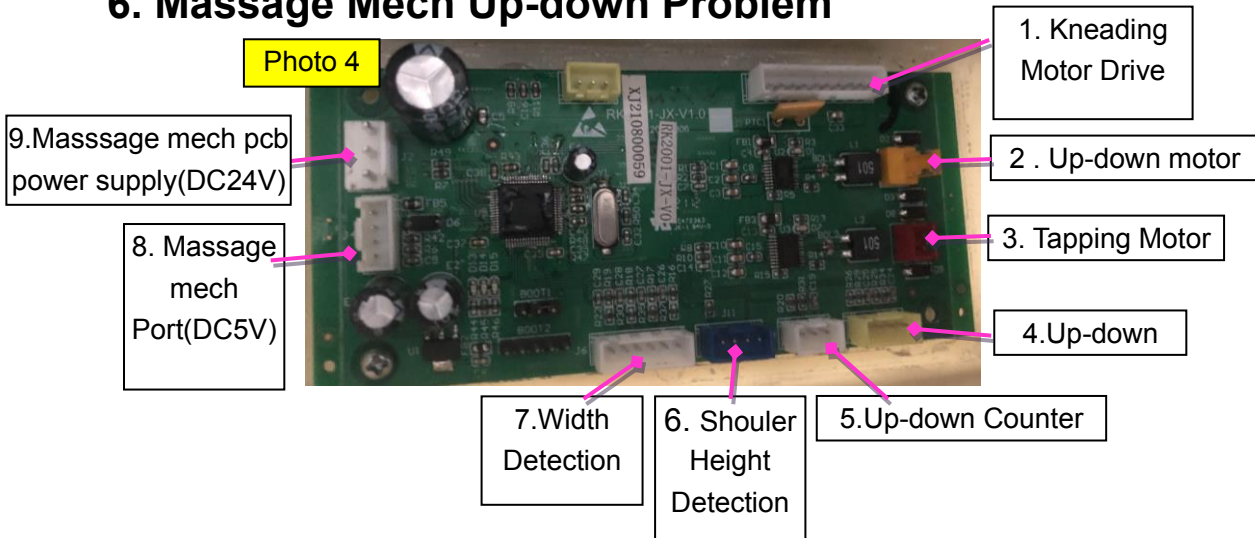

6.1.1 Check if there is DC24V output at connector 2 (orange) of the lifting motor port core board. If there is voltage output, check if the resistance of the lifting motor is normal ( $5\ \Omega$  - $30\ \Omega$ ). If there is no resistance or the resistance is too high, it indicates that the motor is damaged and can be replaced to eliminate the fault.

6.1.2 If there is voltage and the motor resistance is normal, touch the lifting motor housing with your hand to feel if there is any vibration during motor operation. If there is, it indicates that the motor is stuck and the lifting transmission structure needs to be repaired.

6.1.3 If there is no voltage, it indicates that the core board is damaged and shall be replaced.

6.2 When the massage machine is working in the up and

down states, if there is a phenomenon of top or bottom flushing; The lifting limit signal is faulty.

6.2.1 Check if the connector is securely plugged in.

6.2.2 Use a multimeter to beep measure the continuity of the red, yellow, green, and black wire harnesses of the lifting limit harness. If they do not work, replace the lifting limit harness;

6.2.3 Use a multimeter in DC mode to measure whether there is a DC5V voltage between the red and black wires of the lifting limit connector in Figure 4. If there is no voltage, the master board is damaged and can be replaced.



Measure the voltage between the yellow and black wires, as well as the green and black wires, of the connector shown on the right figure.

Use magnets to approach and move away from the upper and lower limit Hall elements respectively, and observe whether there are normal high and low level changes. If there is no change, replace the lifting limit board assembly. Otherwise, replace the core board.

6.3 Select the part area and operate the massage machine throughout the entire process.

6.3.1 Slowly rotate the lifting motor shaft by hand and measure

the high and low voltage changes between the yellow and black wires of the 5 lifting counting connectors in Figure 4 using a multimeter in DC voltage mode. If there is a voltage change, replace the core board. Check if there is a DC5V voltage between the red and black lines. If not, replace the core board

6.3.2 Check if the connectors between the lifting motor counters are securely plugged in. Check the continuity of the lifting counting adapter harness. If not, replace the lifting counting adapter harness. Otherwise, replace the lift counter.

## **7. Shoulder Height Detection Problem.**

7.1 Use a multimeter to measure the voltage between the green and black wires of the shoulder height detection connector in Figure 4 using the DC voltage range. Press and release the rocker arm (with the detection component installed) by hand to measure for any changes in high and low voltage levels. If there is no change in high and low levels, replace the shoulder height detection harness assembly. Otherwise, replace the mech board.

## **8. Kneading problem.**

8.1 Kneading motor is not working: Turn on the controller and select the kneading function. Check if there is a DC24V output

between the red and black lines in Figure 4 No.12 of the kneading motor port core board connector. If there is no voltage output, the core board is damaged and replace the core board. If there is voltage output, check if there is 24V voltage at the kneading motor end. If there is no voltage, replace the kneading motor harness; If there is voltage, the kneading motor damaged and replace kneading motor.

8.2 Once the massage chair is turned on and the kneading function starts running, if it cannot be turned off through manual control, the core board is damaged and needs to be replaced.

## **9. Tap function problem.**

9.1 If the tapping motor does not work, open the manual controller and select the tapping function.

9.1.1 Check if there is a DC24V output at connector 3 (red) of the tapping motor port core board. If there is a voltage output, check if the resistance of the tapping motor is normal ( $5\ \Omega$  -  $30\ \Omega$ ). If there is no resistance or the resistance is too high, it indicates that the motor is damaged and can be replaced to eliminate the fault.

9.1.2 If there is no voltage, it indicates that the core board is damaged and can be replaced.

9.1.3 Once the massage chair is turned on, the tapping function will run. If it cannot be turned off through manual control, the core board is damaged and needs to be replaced.

## **10. Massage mech width adjustment problem(wide, middle and narrow).**

10.1 Turn on the machine, activate the tapping function, and select the wide or narrow kneading motor without stopping.

10.1.1 Check if the magnet on the opposite side of the wide, medium, and narrow circuit board on the rotating shaft has come off. If not, reassemble it.

10.1.2 Use a multimeter to measure the DC voltage range, and check whether there is a high or low level change between the wide signal yellow and black lines or the narrow signal green and black lines of the 7 wide, medium and narrow connectors in Figure 6 of the core. If there is a high or low level change, the core board is damaged and can be replaced.

10.1.3 Check if the connector is securely plugged in; Measure the continuity of the wide, medium, and narrow detection harness using a multimeter buzzer. If not, replace the detection harness assembly. Otherwise, replace the wide, medium, and narrow detection board

## **11. Waist heat problem.**

11.1 Turn on the heating function and measure the voltage at point 7 in Figure 1 to see if it is DC24V; If there is no voltage output, it means the master board is damaged; If there is voltage output, use a multimeter to measure whether the heating wire plug has DC24V. If not, please replace the heating wire; If there is voltage, please replace the heating cloth.

## **12. The remote control screen is abnormal while the button operation function is normal.**

12.1 If the screen display is abnormal and the button operation function is normal, it is generally due to a malfunction of the manual control board display screen. After replacing the manual control assembly, it returns to normal.

## **13.Quick remote control problem.**

13.1 Check if the connectors between the manual controller and the master board are securely connected, and if the wiring harness is properly connected. If there is an abnormal connection or disconnection, replace the corresponding wiring harness assembly.

13.2 Use the DC voltage range of the multimeter to measure whether there is a DC5V voltage at both ends of connector 12 in Figure 1. If there is no voltage, the main circuit board is damaged and the board can be replaced. Otherwise, replace the manual controller board.

### III. Mechanical Failure & Troubleshooting

#### 1. Leg rest assembly

1.1 As shown in the figure below, remove the DK block card, then lift the leg rest, unplug the connectors and air inlet tubes, and remove the leg rest assembly from the chair body



#### 2. Back cover disassembly

2.1 As shown in the figure, use an electric tool to remove the screws on the back cover and remove the back cover by hand.



### 3.rmrest disassembly

3.1 As shown in the figure, unplug the connecting armrest from the whole machine connector, and then unplug the air tube.

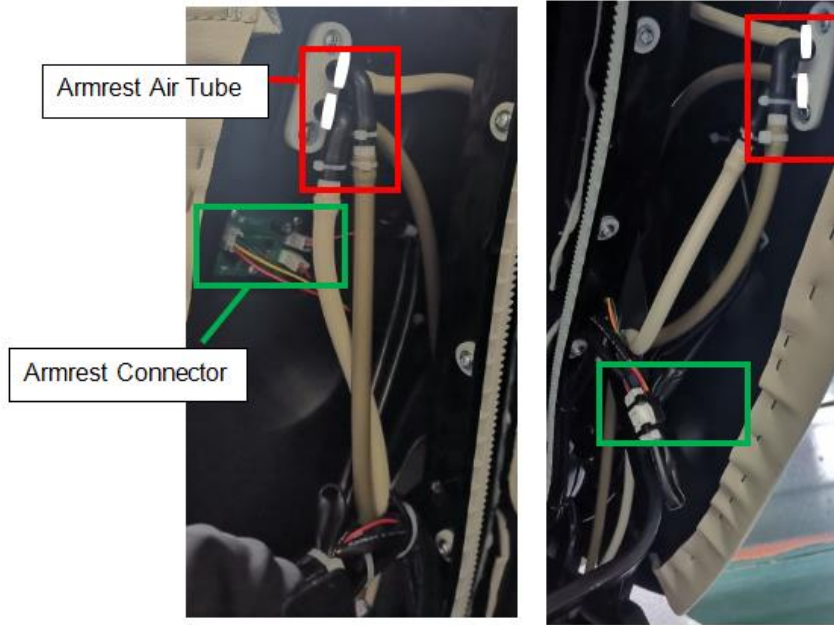

3.2 As shown in the figure, after removing the backrest cover, remove the screws connecting the armrest and the backrest, then remove the screws fixing the armrest at the front of the massage chair, and the armrest assembly is disassembled.



### 4.Massage machine disassembly

4.1 Disconnect the massager wiring harness.

4.2 As shown in the figure, use tools to remove the screws of the guide rail connecting plate, remove the guide rail connecting plate, and then turn the lifting motor of the massage machine in the direction of the guide rail to remove the massage machine.

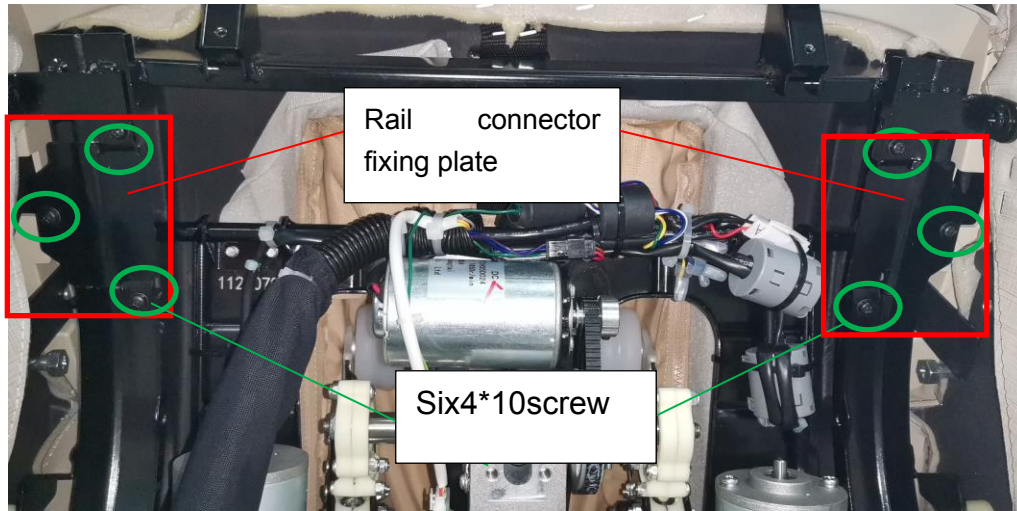

The guide rail is connected to the notch of the fixing plate.

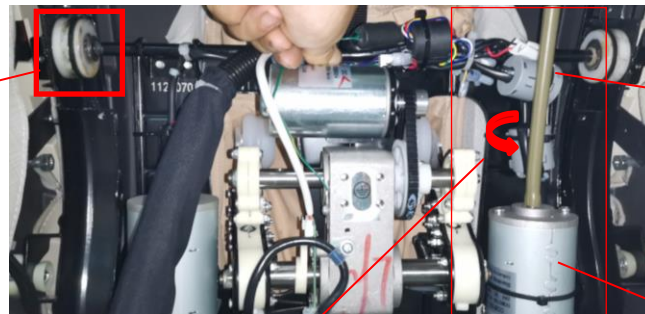

Anticlockwise

## 5. Disassemble the power box air pump.

### 5.1 Remove the upper cover of the power box:

Use a tool to remove the two screws that fix the upper shell of the power box, and remove the upper shell of the power box.



### 5.2 To disassemble the air pump:

Remove the fixing screws of the air pump with a tool, then cut off the nylon cable tie with diagonal nose pliers, unplug the air pump wiring harness and air pipe, and remove the air pump assembly

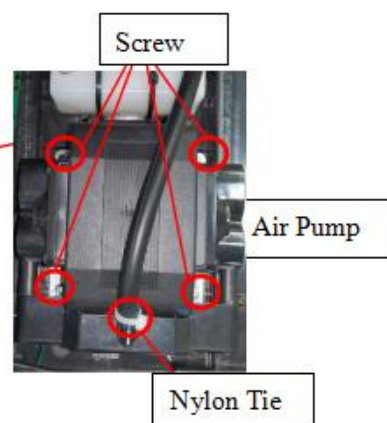
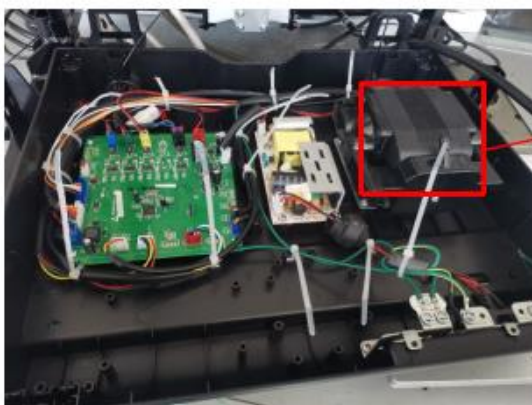

## 6、 Replace the solenoid valve assembly.

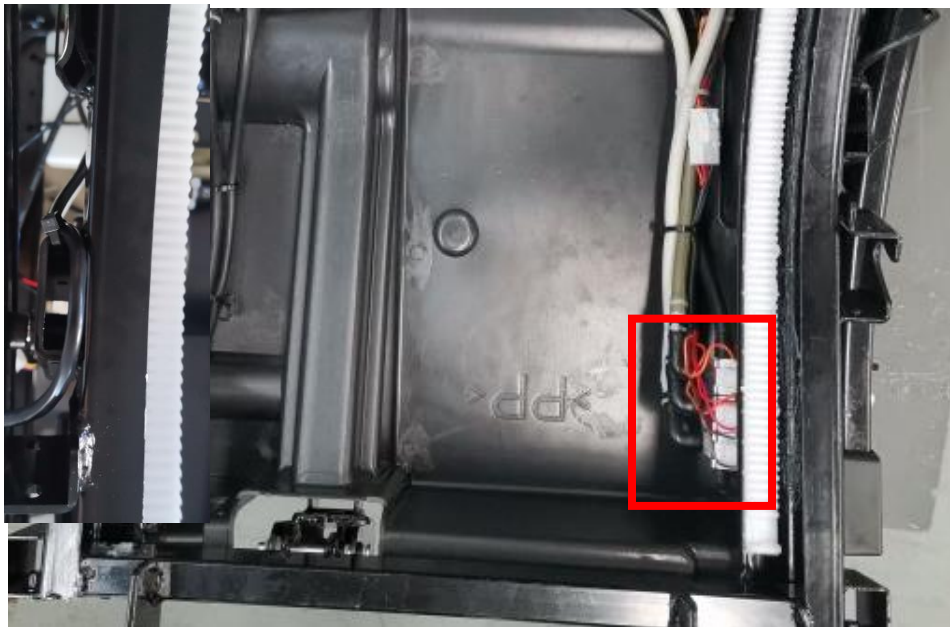
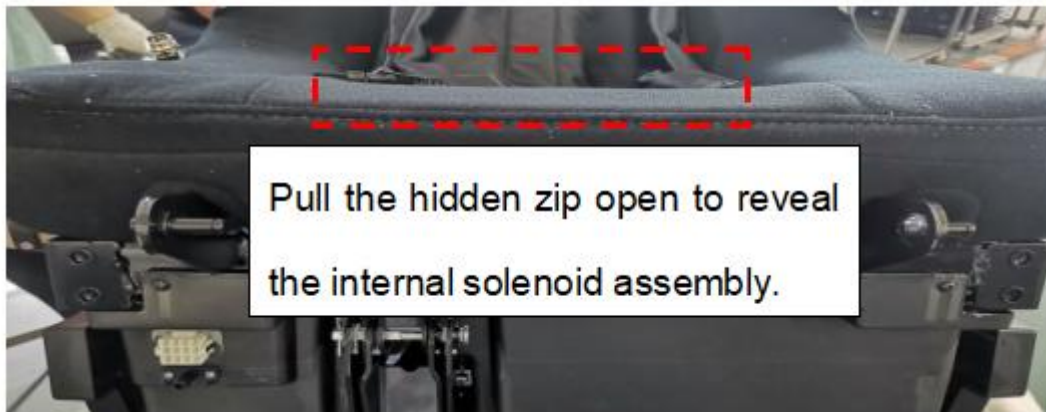

Remove the backrest sewn assembly, then unzip the sewn product of the backrest front cover (seat position), cut the nylon cable tie connecting the solenoid valve with oblique nose pliers, unplug the connector, and then remove the solenoid valve assembly with a tool and replace it with a new solenoid valve assembly.

**7、 To replace the strut assembly (it is recommended that 2 people cooperate to disassemble the electric strut, one person supports the backrest assembly, and one person disassembles the electric strut), you need to remove the leg and foot assembly first.**

### **7.1 Seat removal assembly strut:**

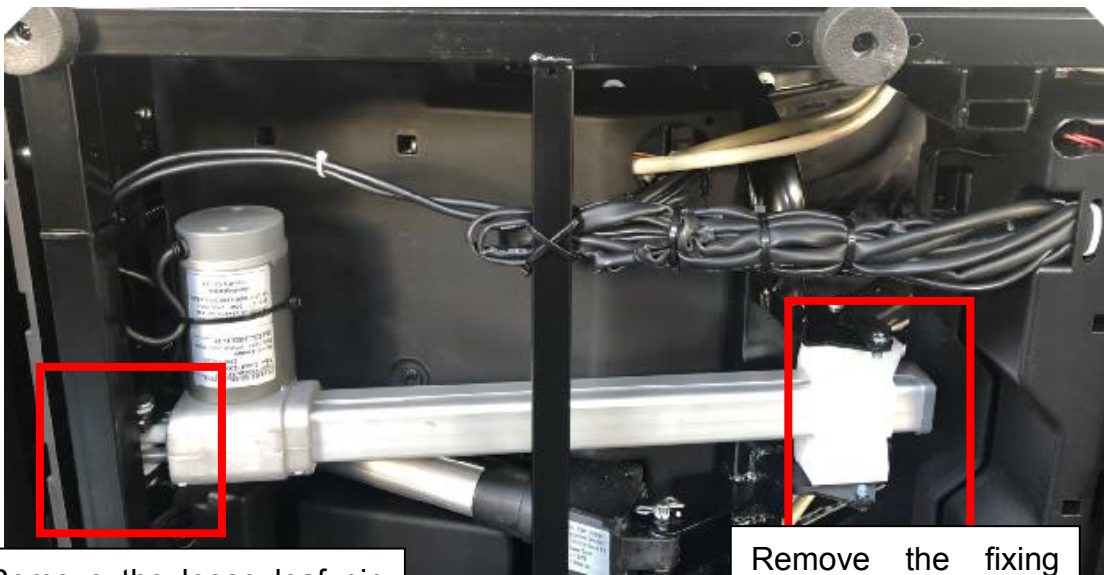

Remove the loose leaf pin and pin of the fixed strut.

Remove the fixing strut screws with a tool.

First, gently place the massage chair on the ground (one side of the armrest) to expose the seat strut assembly, gently shake the backrest assembly to remove the pine leaf pin and pin of the fixed strut rod, and then remove the screw at the other end with a tool, remove the connector and replace the seat strut assembly.

### 7.2 Dismantle the leg strut assembly:

First, gently put down the massage chair (one side of the armrest touches the ground), expose the leg brace assembly, gently shake the backrest assembly to remove the pine leaf pins and pins at both ends of the fixed strut, and remove the connector to replace the leg and foot brace assembly.



Remove the pine leaf pins and pins at both ends.



Φ8 Sleeve+8\*4 Pinroll +Greese+Pine leaf pin

### IV.iC rcuit board component layout diagram

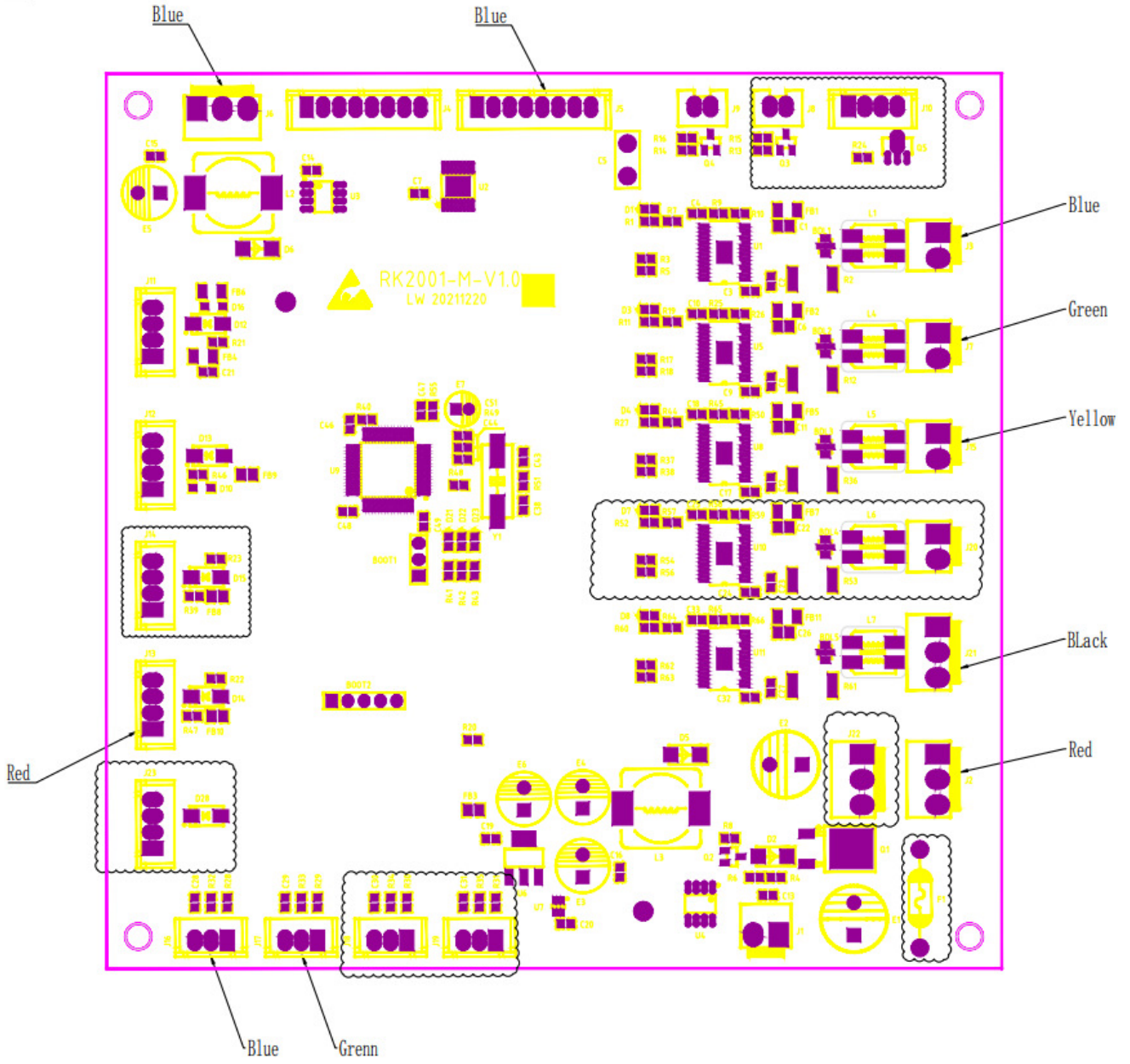



## 2. Massage Mech PCB

