

Nexus (EC-8607) massage chair service guide



Table of Contents

- 一、 Product introduction
- 二、 Massage chair tools and use
- 三、 Circuit working principle
- 四、 Massage chair removal instructions
- 五、 Massage chair fault judgment



EASEPAL

厦门蒙发利电子有限公司客户服务部

二、 Massage chair tools and use

1.tools

					
Screwdriver size 1,2,3	Diagonal cutter and long nose pliers	Soldering Kit	Spanner tools Kit	Test pen	Allen Key set
					
Ratchet Tools Set	24V/DC power	Electric Driver	electrical adhesive tape	Cable Ties	WIRE ONECTORS



2.Usage of multimeter

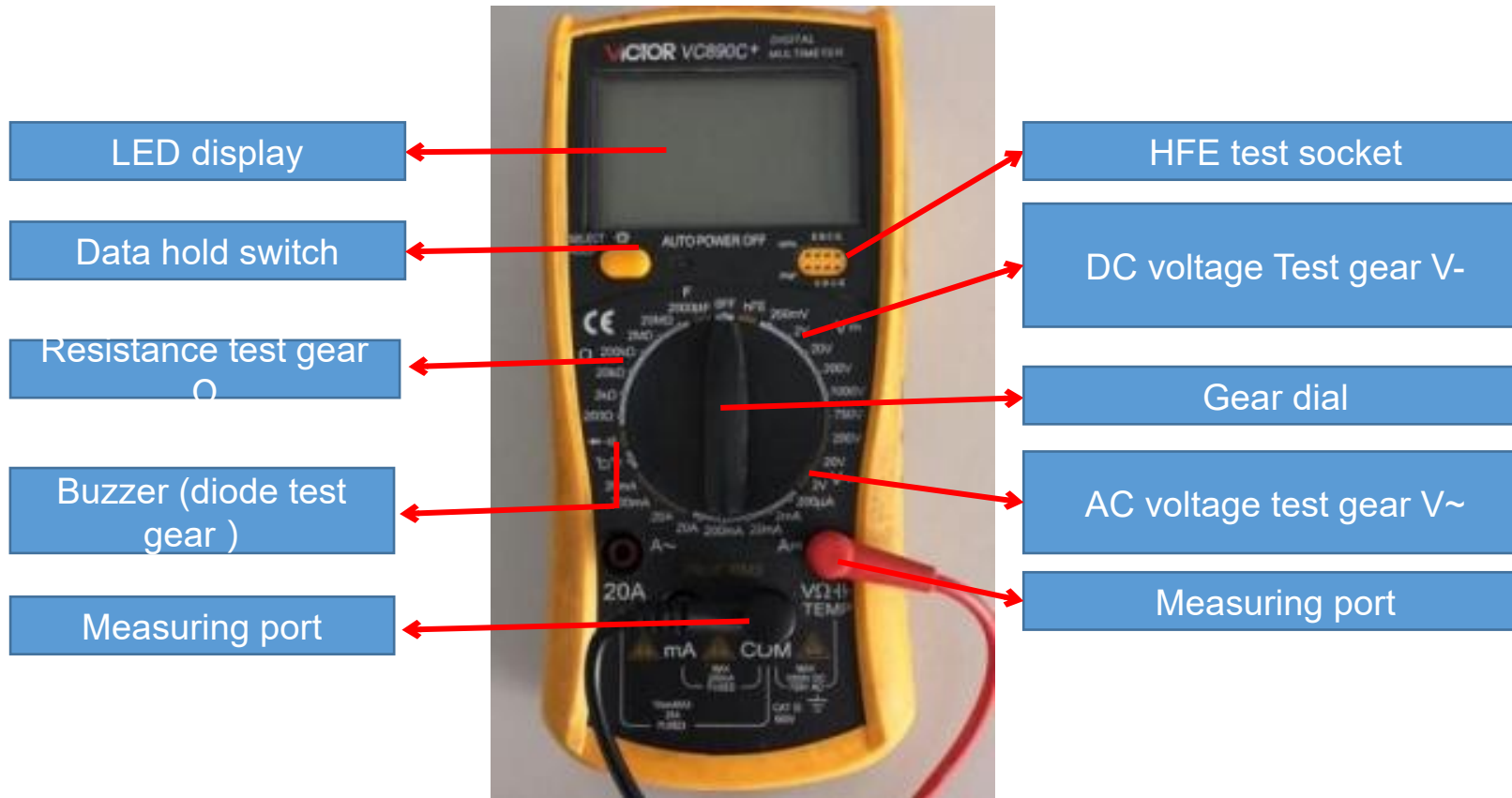



2.1 、 Function of the test gears

Data hold switch : Memorize the measured data for comparison 。

Buzzer (diode test gear) : Measure the quality of diode, the on-off and alarm function of circuit

Resistance gear test gear : Measure the quality and value of resistance

DC voltage Test gear V- : Measure DC voltage

AC voltage test gear V~ : Measure AC voltage

VΩ / COM : VΩ Red pen port (+ pole) during test, black pen port (- pole) during com test

Note: when carrying out resistance or voltage test, it is necessary to select a suitable range. If the range is too small to be measured, and the range is too large, the test error range is large; if the voltage is not known, it is necessary to select a range measurement with a large windlass.



2.2 、 On / off measurement of lines



open circuit



As shown in the left picture, first set the multimeter to the buzzer and power it
When the switch is on, the multimeter will display "0."; then contact the two probes with the ends of the red wire
At this time, the multimeter still shows "1." there is no change, which means there is an open circuit in the middle of the wire, that is, the line is open.



close
circuit



As shown in the picture on the left, if the multimeter shows the number of ". 002" or ". 00n" and gives an alarm, it means that the wire is connected.

2.3、 Measurement of AC voltage



As shown in the picture above: measure the household plug-in board power supply (220V), select the range of 750, and the test result shows "224", indicating that the actual voltage of this group of sockets is 224v at the moment (the switch is pressed down, so there is power, and the light is on).



As shown in the above picture: measure the power supply (220V) of our household plug-in board, select the range of 750, and the test result is displayed as "001", indicating that the actual voltage of this group of sockets is 0V at the moment (the switch is not pressed down, so there is no power, and the light is not on).

2.4、 Measurement of dc voltag



As shown in the figure above: the test result shows "1.58", indicating that the voltage at both ends of the battery has 1.58V, and the red watch pen is connected to the battery's "+" pole, while the black pen is connected to the electromagnetic "-" pole.



As shown in the figure above: the test result shows "-1.58", indicating that the voltage at both ends of the battery has 1.58V, and the red watch pen is connected to the battery "-" pole, and the black pen is connected to the electromagnetic "+" pole.



EASEPAL

3、Circuit working principle 厦门爱成利电子有限公司客户服务部

1、main PCB :

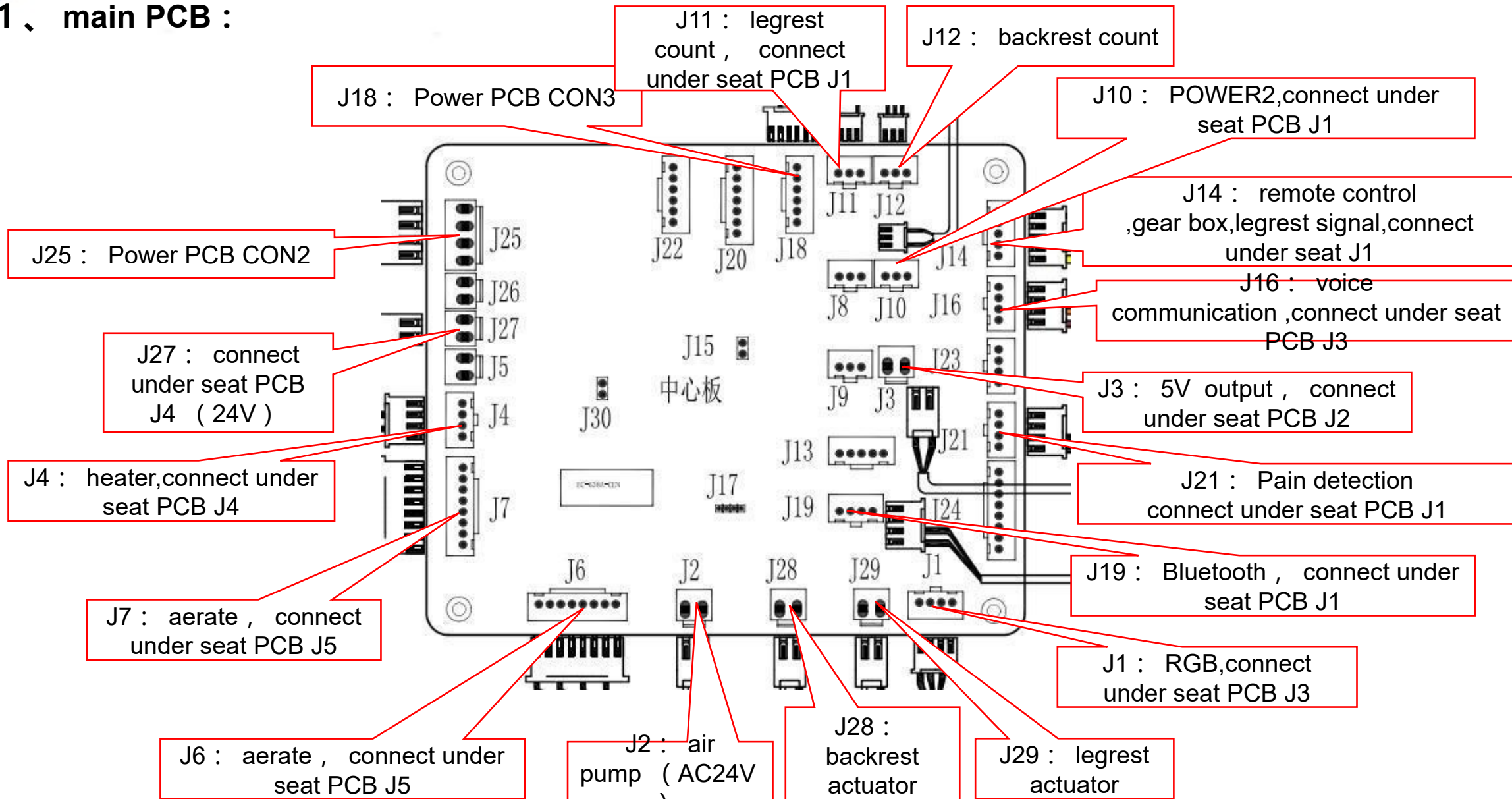



EASEPAL

厦门爱普尔电子有限公司客户服务部

1、 under seat PCB :

J32: air valve(under seat)

J16:3-way air valve(under seat)

J31 : wireless charger

J7 : right side panel switch PCB J1

J9 : legrest actuator count

J17 : legrest PCB J2

J26 : 3D PCB CN3

J18 : remote control J1

J18 : right side panel switch PCB J1

J10 : voice interaction PCB J3

J1 : Bluetooth , legrest count , Pain detection , remote control , side panel signal 、 5V output 、 legrest/gear box/remote control/side panel communicate

J2 : 5V input, connection main PCB J3

J5 : shoulder, seat, and waist inflatable connection main PCB J6

J4 : heating(backrest) , 24V input connection mian PCB J4 、 27

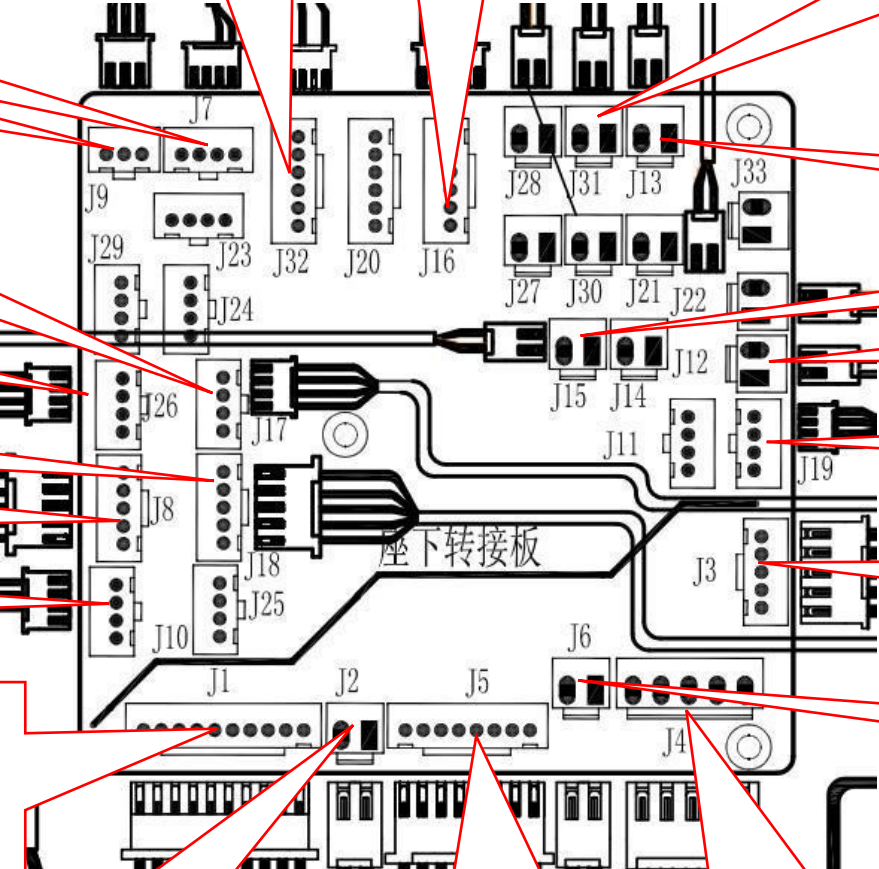

J13 : 3D PCB CN17

J15 白: voice interaction PCB J2

J12 : heating(backrest)

J19 红: Side panel light strip

J3 : RGB conversion input main PCB J1

J6 : Reserved 12V power supply



3、legrest PCB :

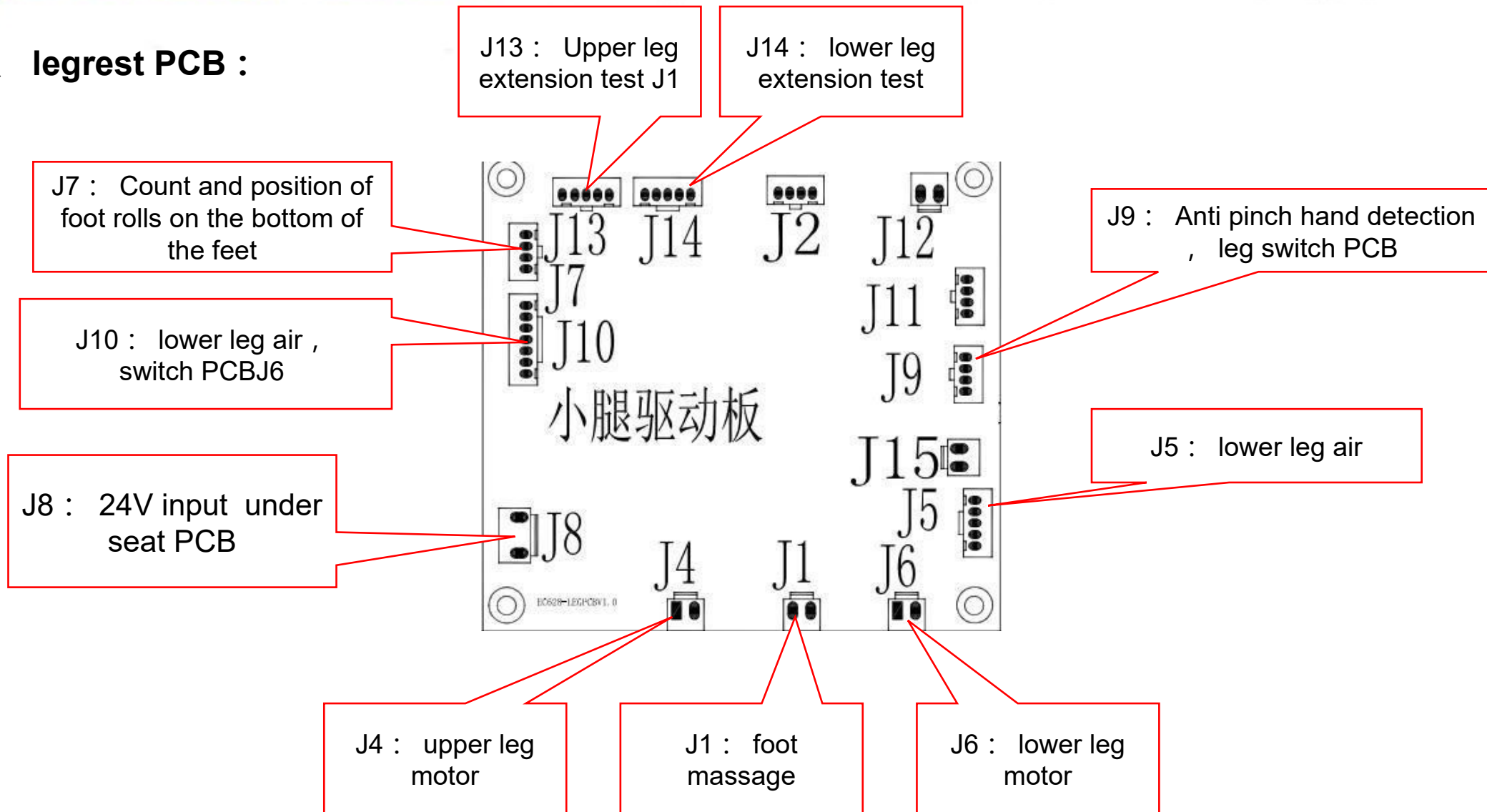



4、 side panel switch PCB :

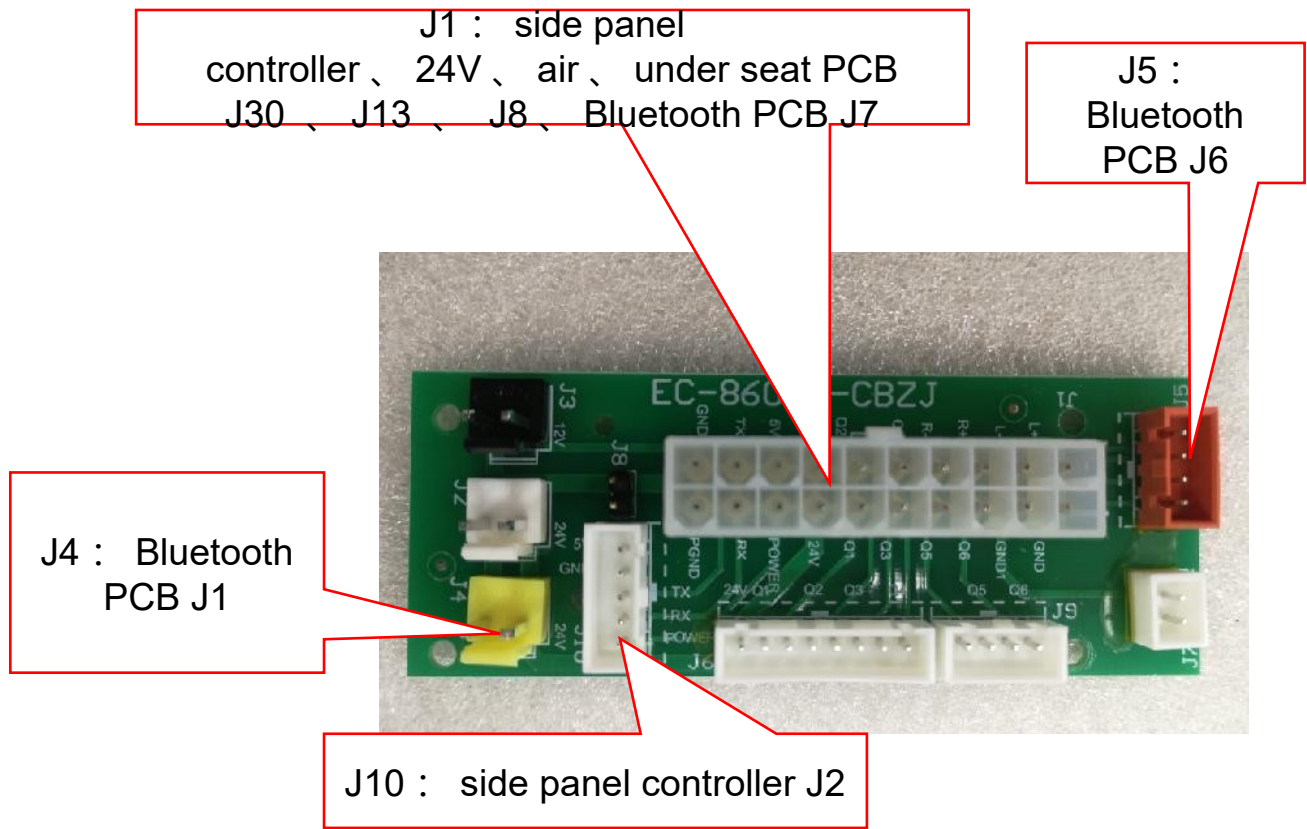



5、3D PCB :

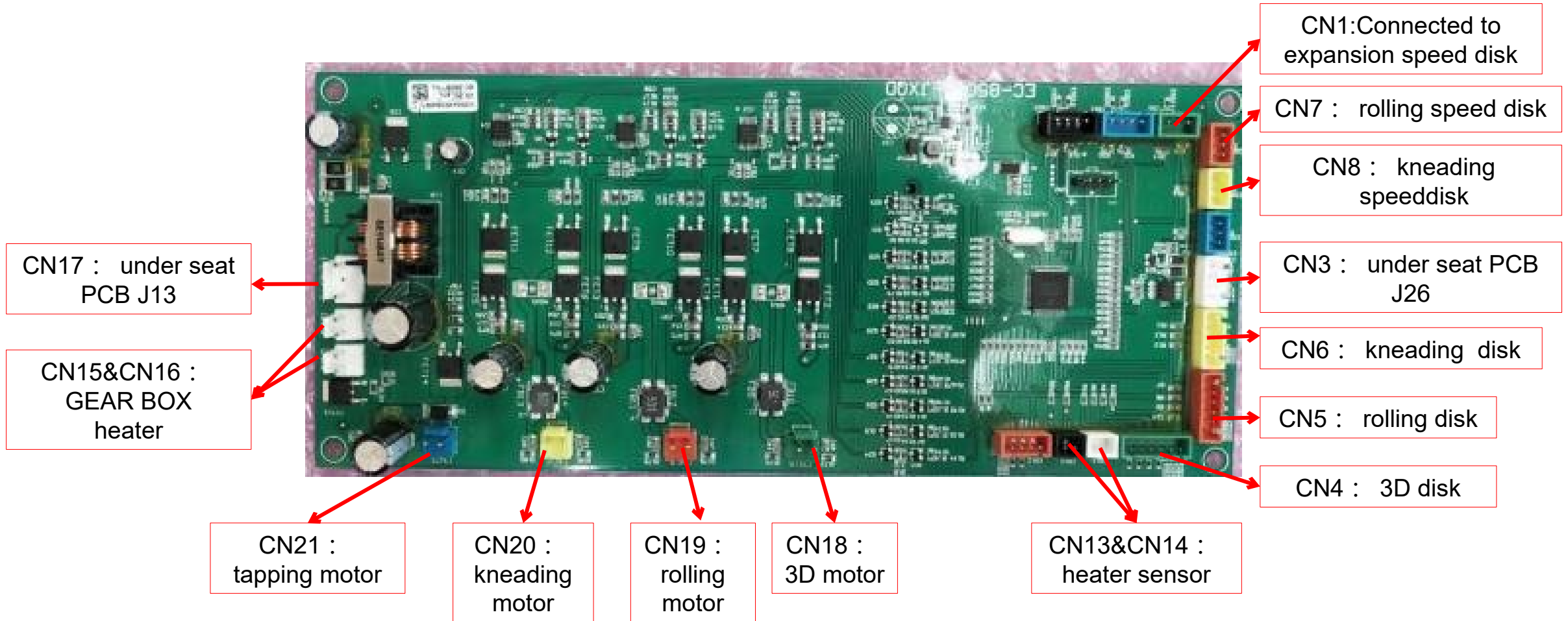



EASEPAL

厦门蒙发利电子有限公司客户服务部

4、 Massage chair removal instructions

1.1、 Internal structure diagram (overall) :

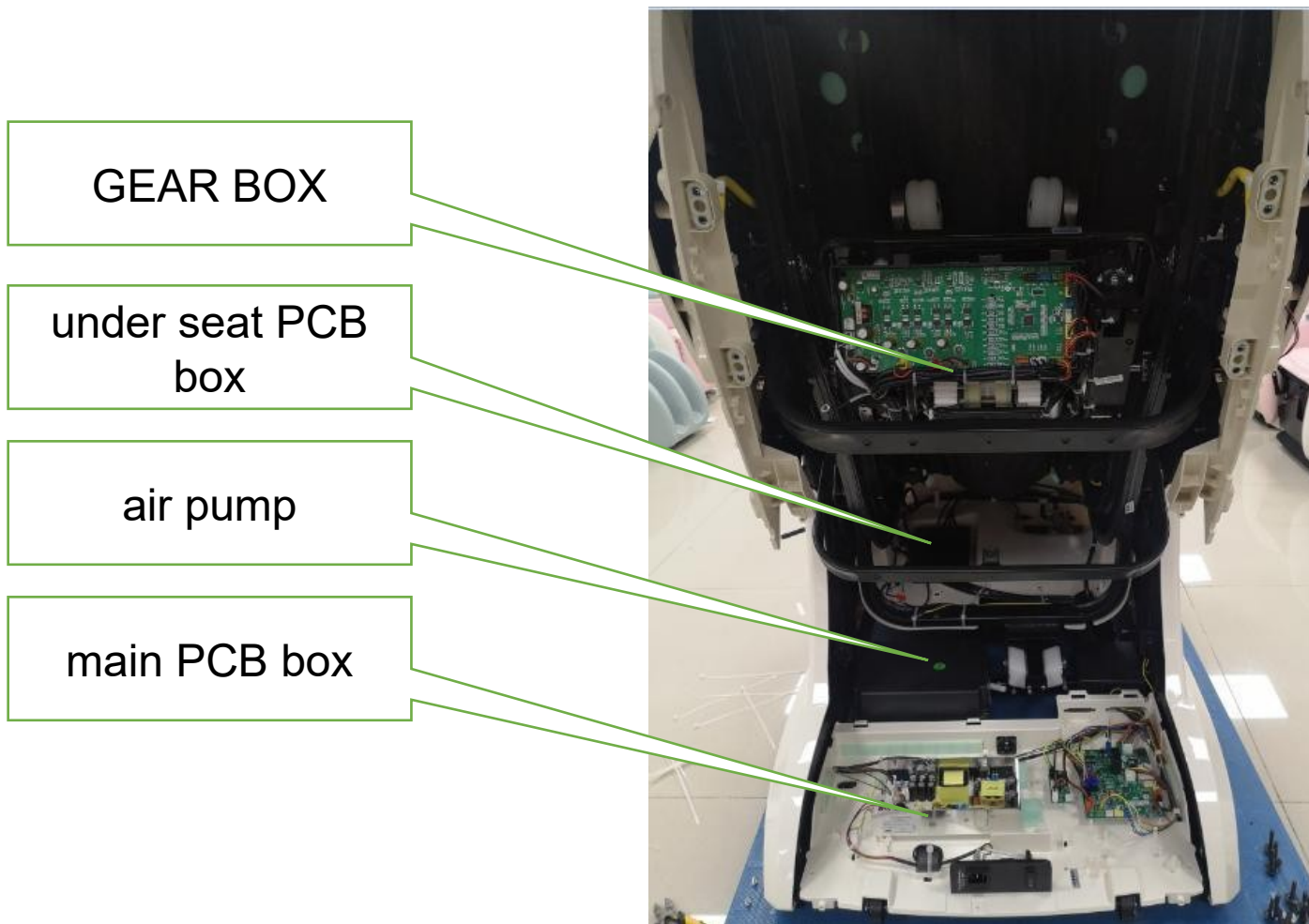



1.2、 Internal structure diagram (main PCB box) :

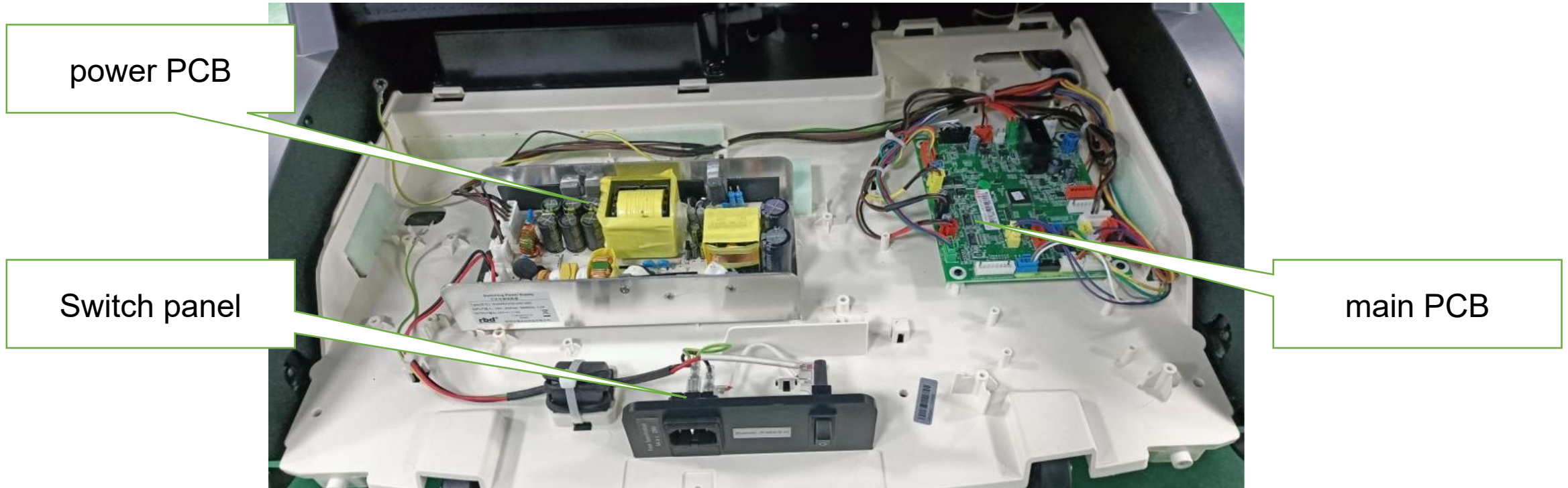



1.3、 Internal structure diagram (legrest) :

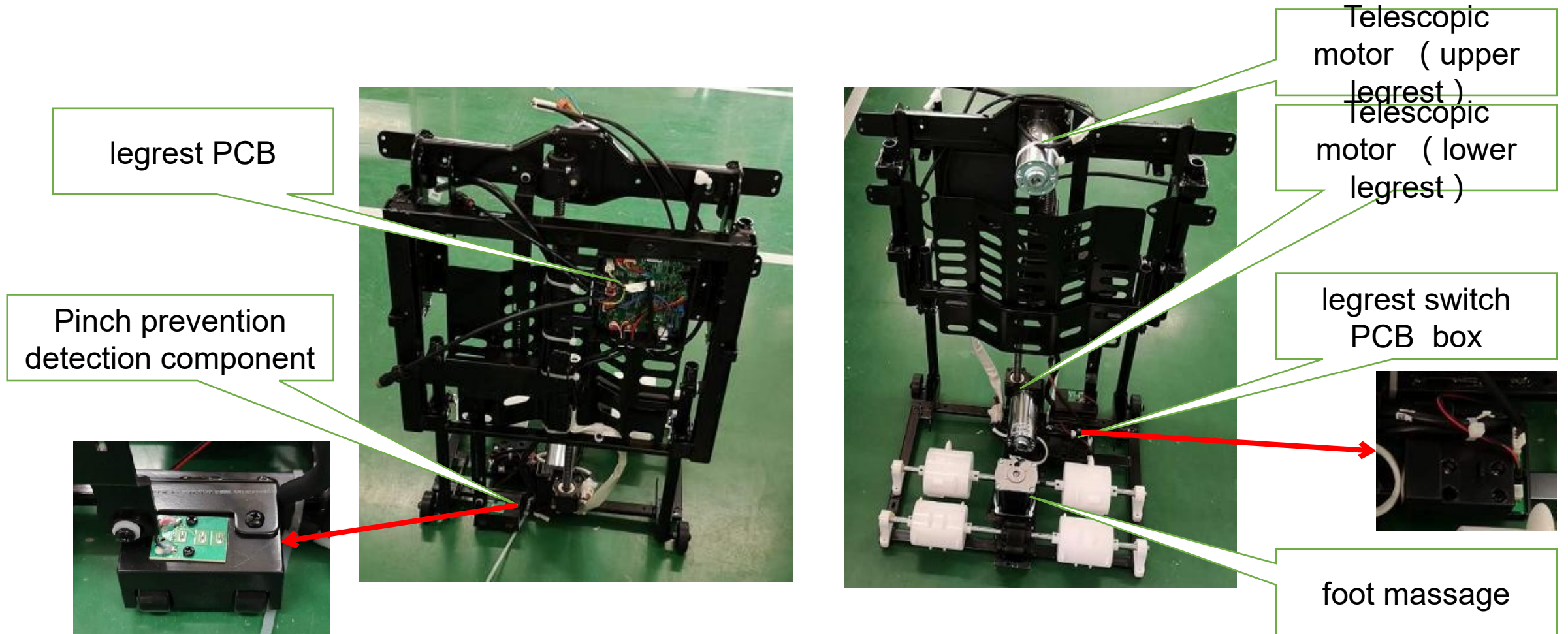

2、disassembly of the pillow:

EASEPAL. 厦门蒙发利电子有限公司客户服务部



1. unzip the zipper



2. pillow

3、 disassembly of backrest pad :



1. unzip the zipper



2. unzip the zipper



3. unzip the zipper



4. unzip the zipper



5. Remove Sticky Wool Buckle



6. Disconnect the heating terminals on both sides



7. unzip the zipper



8. backrest pad

4、 disassembly of rear cover :



厦门蒙发利电子有限公司客户服务部



1. remove 6 screws

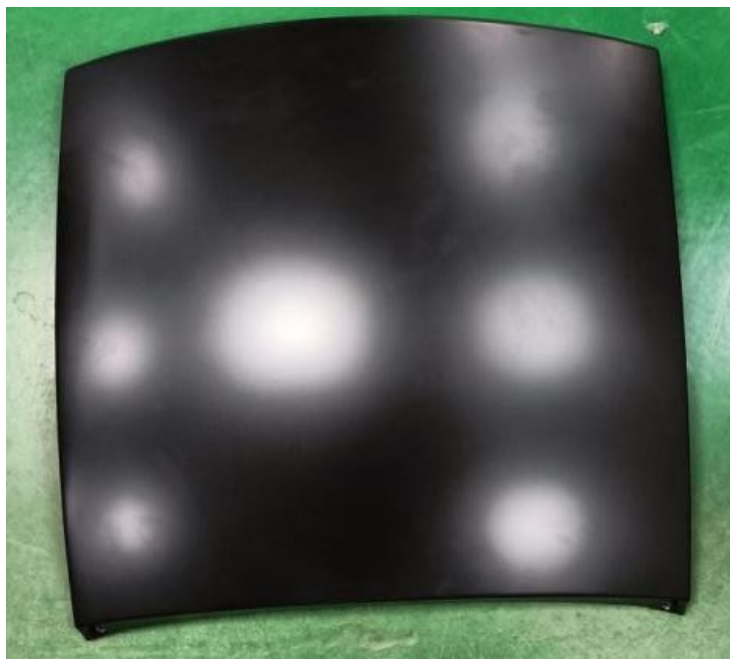

2. upper rear cover



3. rear cover

5.1 、 disassembly of right side panel cover : (remove the rear cover first)



1. remove 2 screws



2. Pull apart the right side panel cover

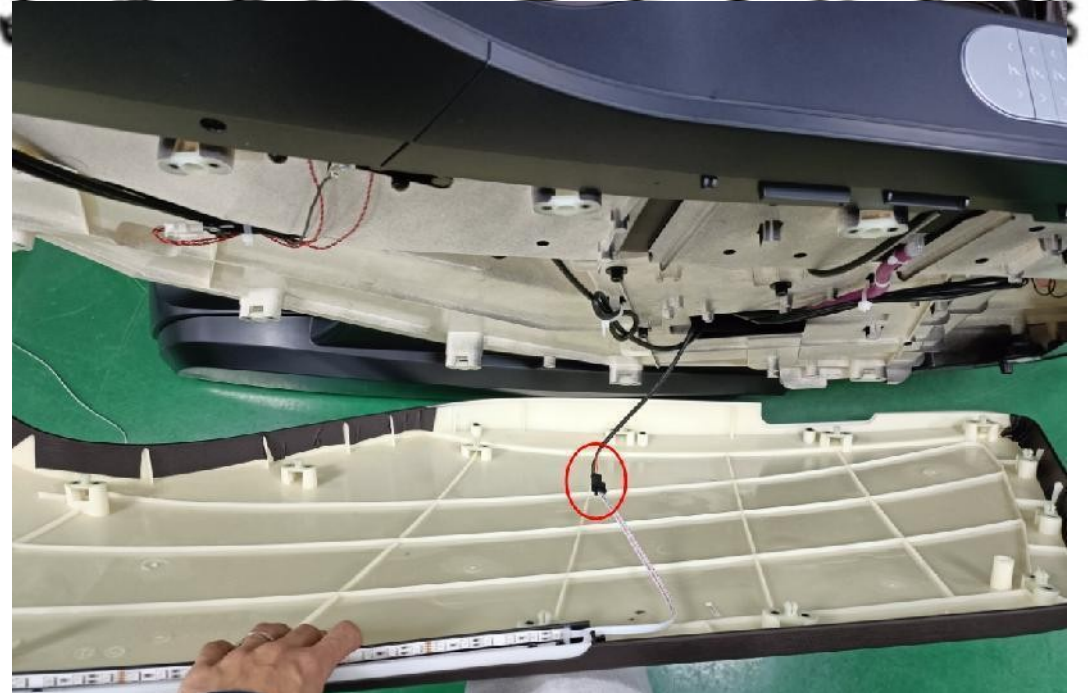

3. Disconnect the LED strip terminals



4. right side panel cover

5.1.1、disassembly of voice interaction PCB : (remove the right side panel cover first)
厦门蒙发利电子有限公司 客户服务部

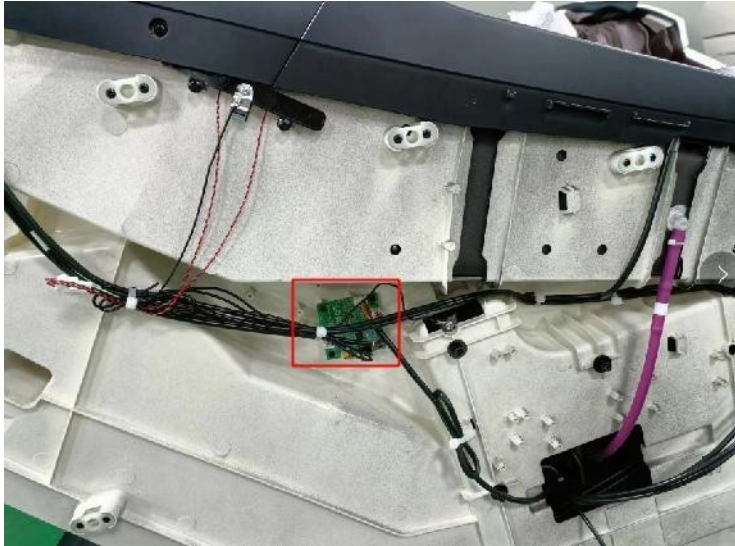

1. Disconnect the terminals of the voice interaction PCB

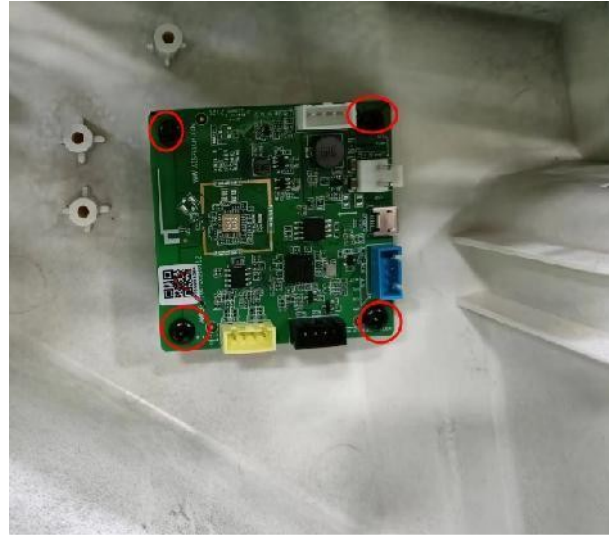

2. remove 4 screws



3. voice interaction PCB

5.2、 disassembly of left side panel cover : (remove the rear cover first) :



1. remove 2 screws



2. Pull apart the left side panel cover

利电子有限公司客户服务部

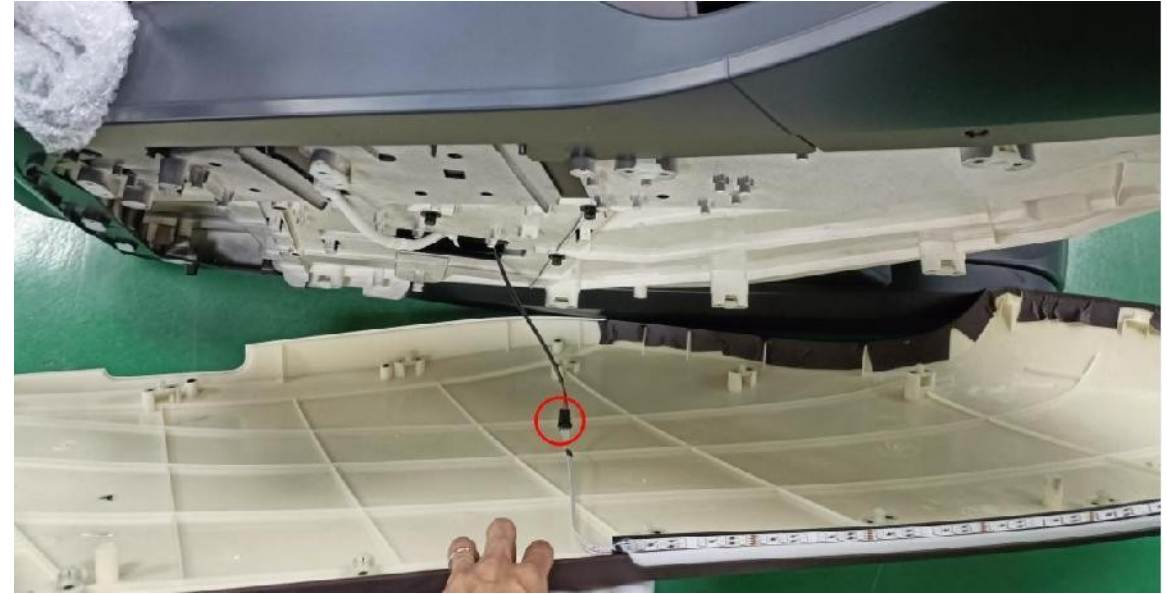

3. Disconnect the LED strip terminals



4. left side panel cover

6、 disassembly of right front side panel cover and right upper side panel cover:(remove the right side panel cover first)

EASEPAL. 厦门蒙发利电子有限公司客户服务部



1. remove 1 screw



2. remove 2 screws

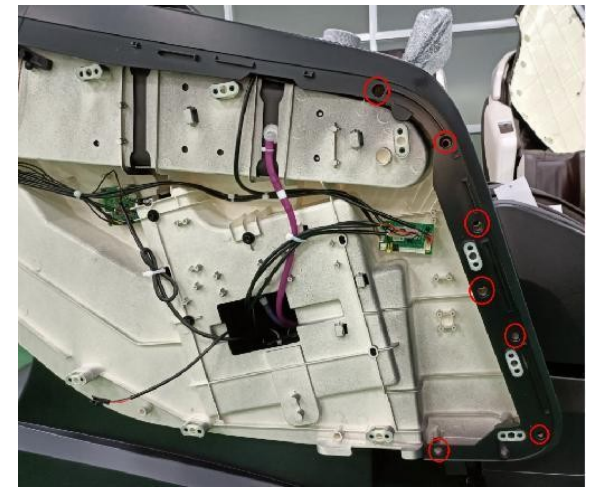

3. remove 7 screws

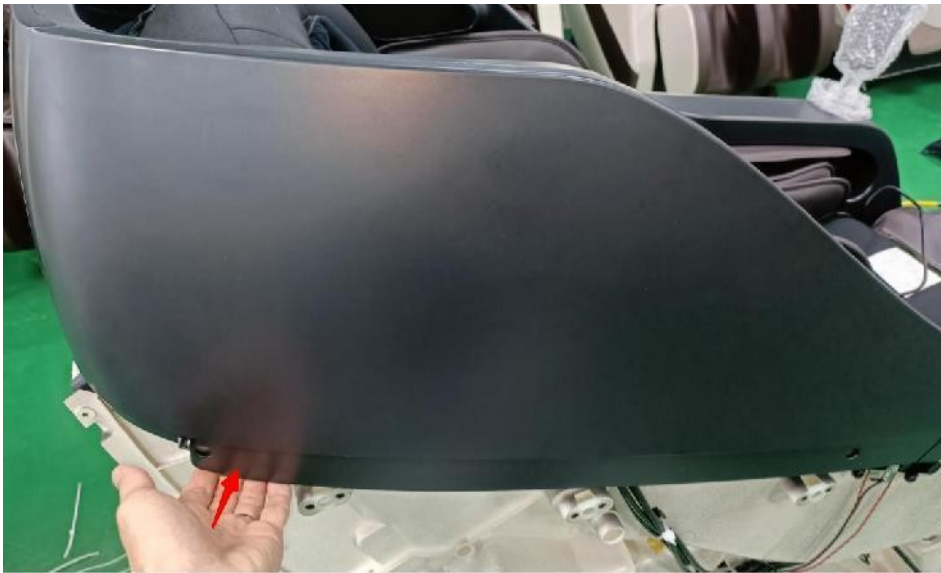

4. Pull apart the right front side panel cover and right upper side panel cover



5. right front side panel cover and right upper side panel cover



EASEP

上海易普尔电气有限公司

公司客户服务部



1. remove 2 screws



2. right upper side panel cover



3. right front side panel cover

7、 disassembly of left front side panel cover and left upper side panel cover:(remove the left side panel cover first)



1. remove 1 screw



2. remove 2 screws



2. remove 7 screws



4. Pull apart the left front side panel cover and left upper side panel cover



5. left front side panel cover and left upper side panel cover



1. remove 2 screws



2. left upper side panel cover



3. left front side panel cover

7、 disassembly of middle outer hood:(remove left&right side panel cover, left&right front side panel cover, left & right upper side panel cover first)



1. remove 2 screws



2. remove 6 screws



3 middle outer hood

7.1、 disassembly of Bluetooth PCB :

厦门蒙发利电子有限公司客户服务部

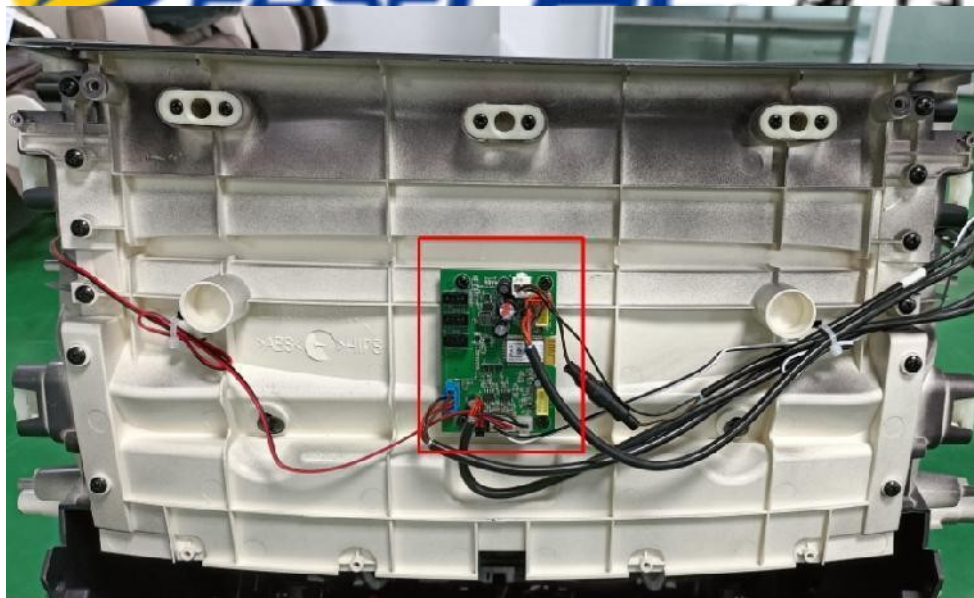

1. Disconnect the terminals of the Bluetooth PCB



2. remove 4 screws



3. Bluetooth PCB

7.2、disassembly of middle inner hood :

厦门蒙发利电子有限公司客户服务部

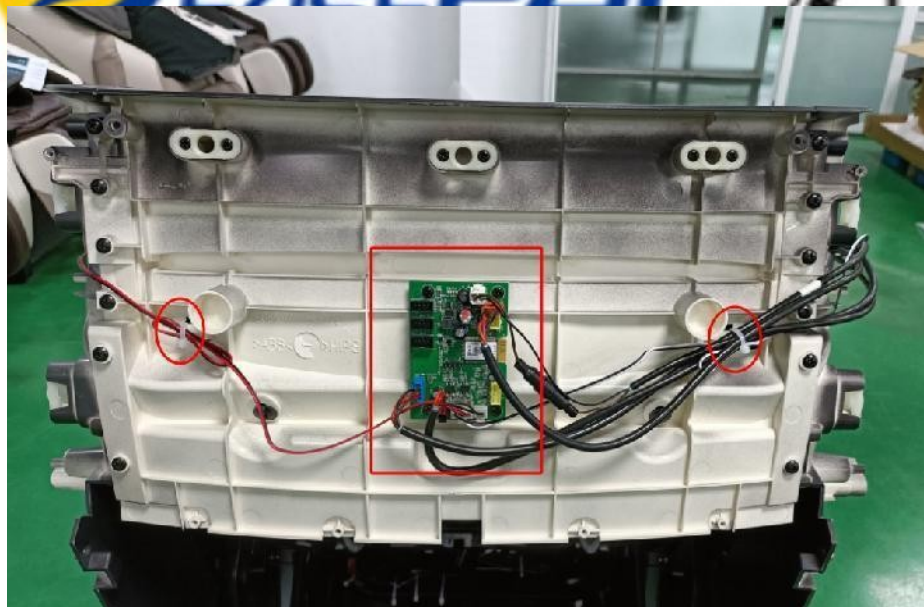

1. Disconnect the terminals of the Bluetooth PCB and cut off the cable ties

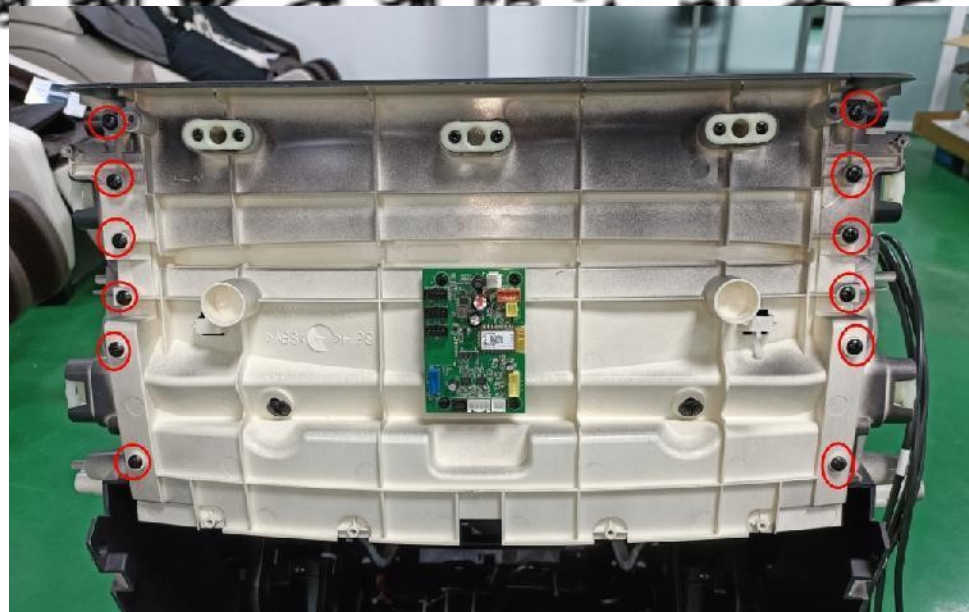

2. remove 12 screws



3. middle inner hood

8、disassembly of left&right speaker (remove the middle outer hood first) 厦门蒙发利电子有限公司客户服务部

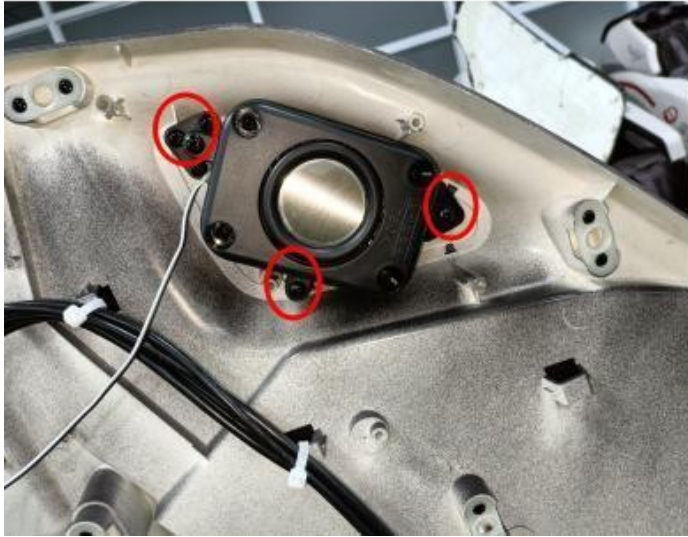

1. remove 3 screws



2 remove 3 screws

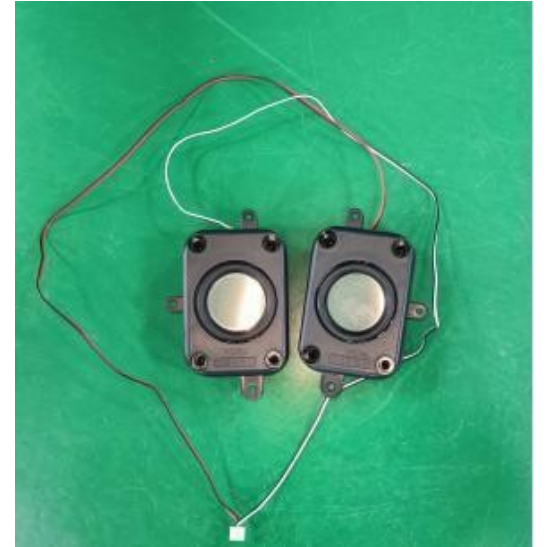

3 speaker

9、 disassembly of right side panel :(remove the middle inner hood and speaker first)

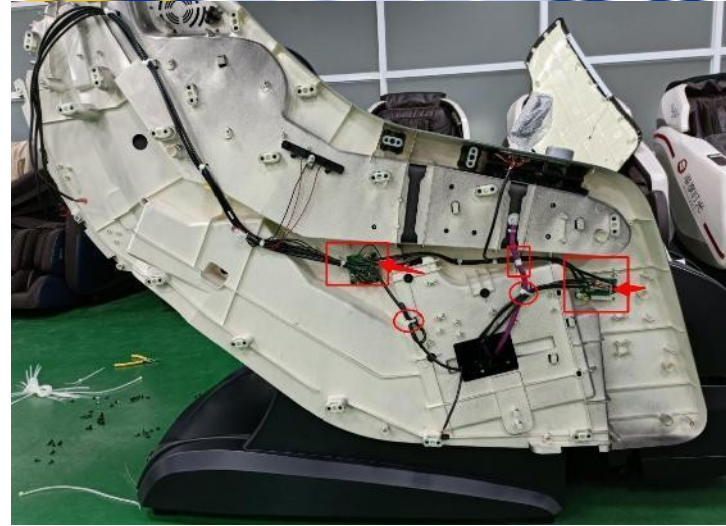

1 Cut off the cable ties, disconnect the terminals, and disconnect the air hose interface

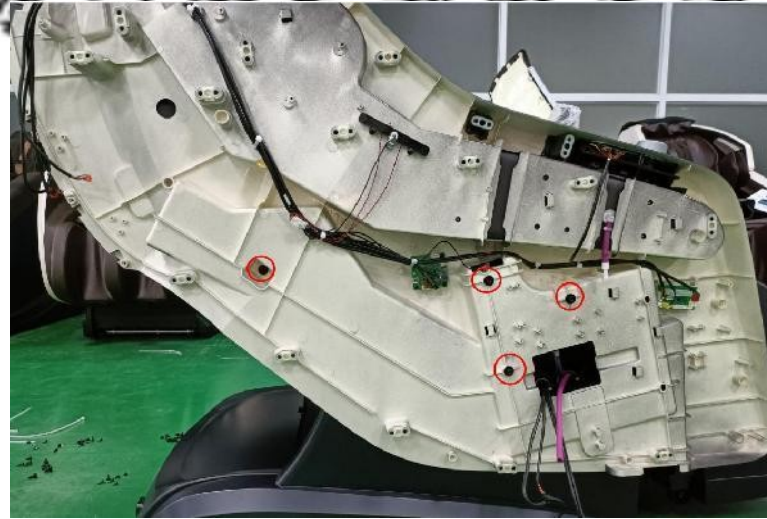

2 remove 4 screws



3. unzip the zipper



4. remove 3 screws



5 Pull upwards to remove the right side panel



6 right side panel

9.1、disassembly of side panel controller :

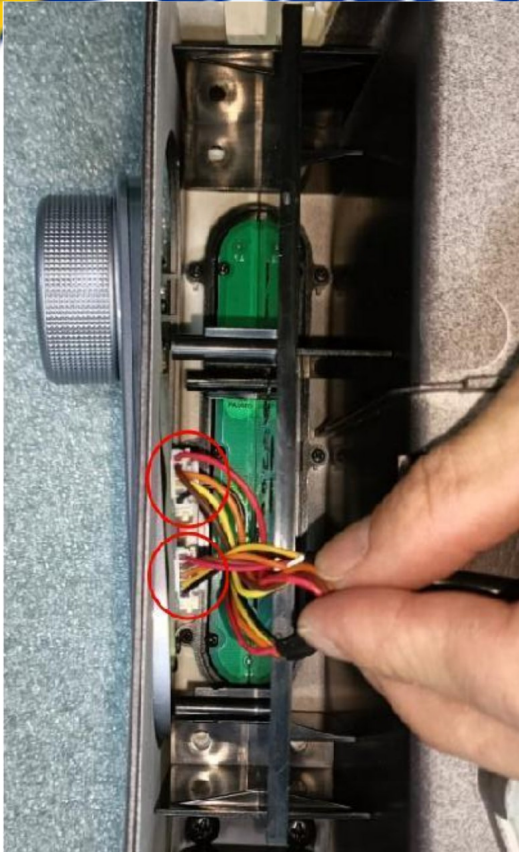

1.Disconnect the terminals



2 remove 3 screws



3 side panel controller

9.1.1、disassembly of side panel controller button :

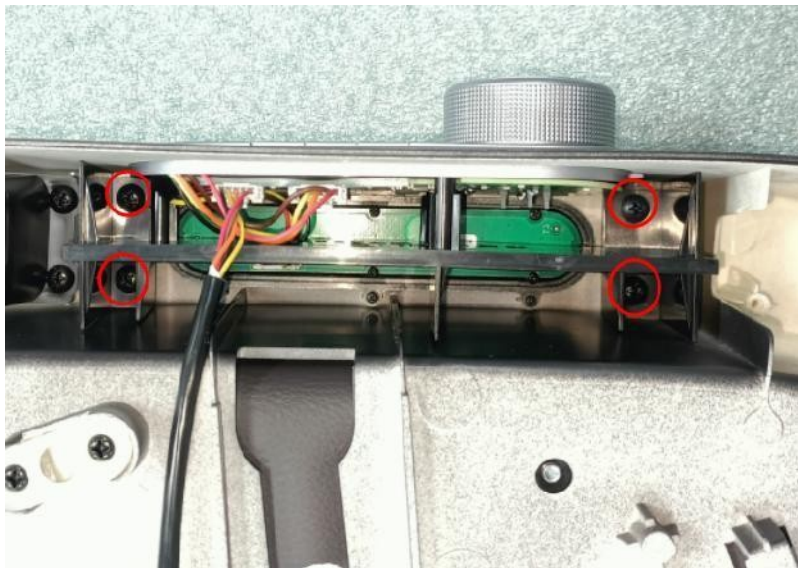

1. remove 4 screws

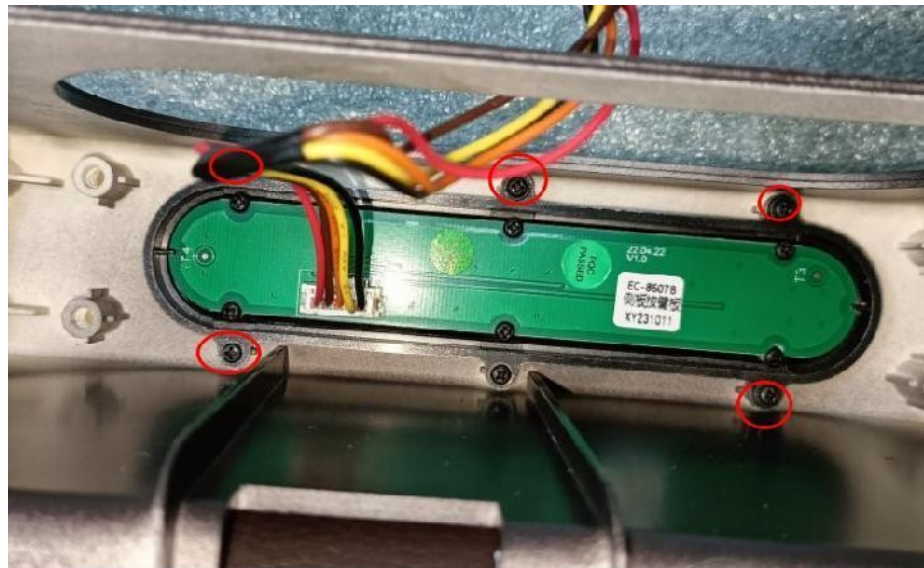

2 remove 6 screws



3 side panel controller button

10、 disassembly of left side panel :(remove the middle inner hood and speaker first)

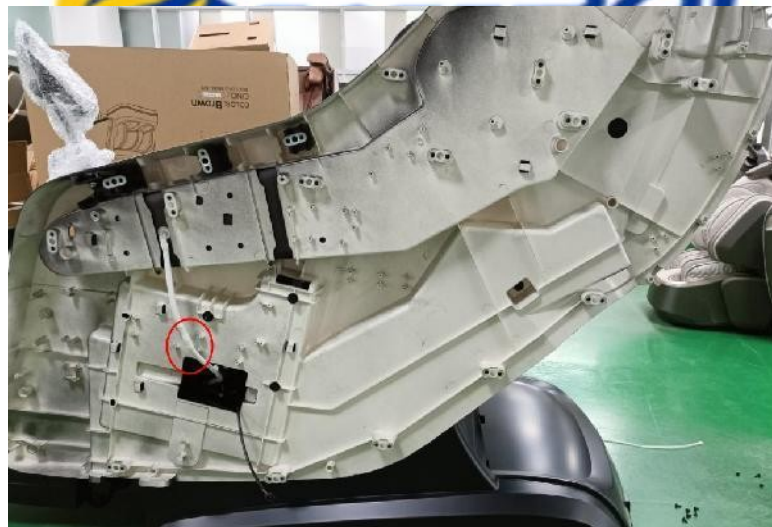

1 Disconnect the air hose

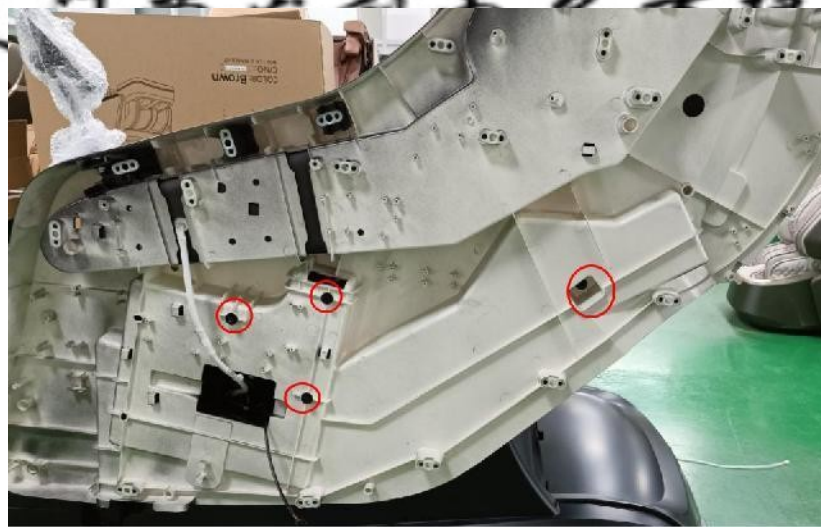

2 remove 4 screws



3. unzip the zipper



4. remove 3 screws



5 Pull upwards to remove the left side panel



6 left side panel

10.1、 disassembly of remote control(remove the left side panel first)

EASEPAL. 厦门家发利电子有限公司客户服务部



1 remove 1 screw



2 Disconnect the plug terminals



3 remote control

11、 disassembly of armrest airbag :



厦门蒙发利电子有限公司



1 unzip the zipper



2 remove 2 screws



3 unzip the zipper , remove the cover



4 armrest cover



5 remove 4 screws



6 armrest airbag

12、 disassembly of shoulder airbag:(remove the left&right side panel first)



1 Disconnect the air hose interface and unzip the zipper



2 remove 4 screws



3 remove the cover



4 shoulder cover



5 remove 2 screws



6 shoulder airbag

13、 disassembly of side seat airbag:(remove the left&right side panel first)



1 Disconnect the air hose interface



2 remove 2 screws



3 remove the cover



4 side seat cover



5 remove 2 screws



6 side seat airbag

14、 disassembly of backrest cable :



1.remove 4 screws and cut cable tie

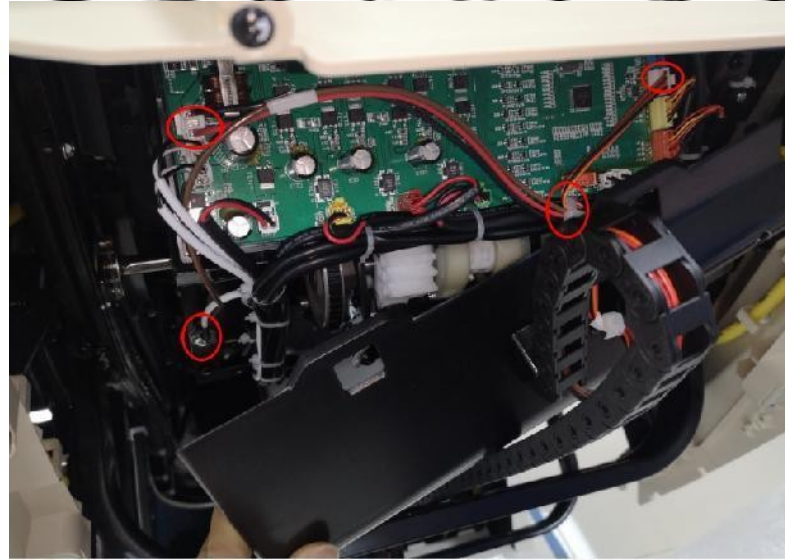

2.Unplug the terminal, remove the ground wire, and cut the cable tie



3.gear box protective cover

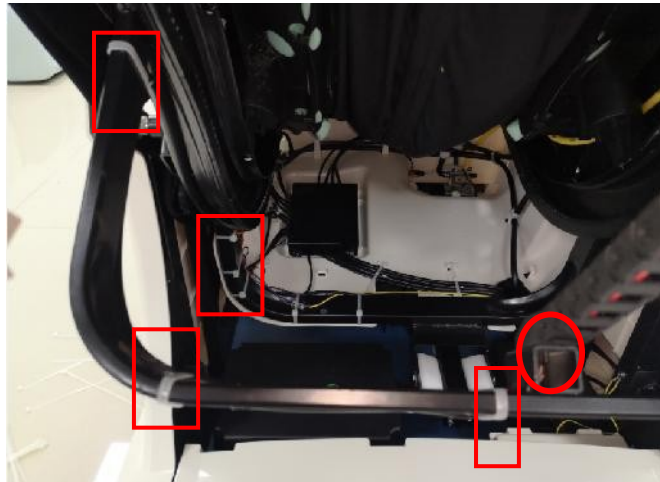

4.remove 2 screws and cut cable tie

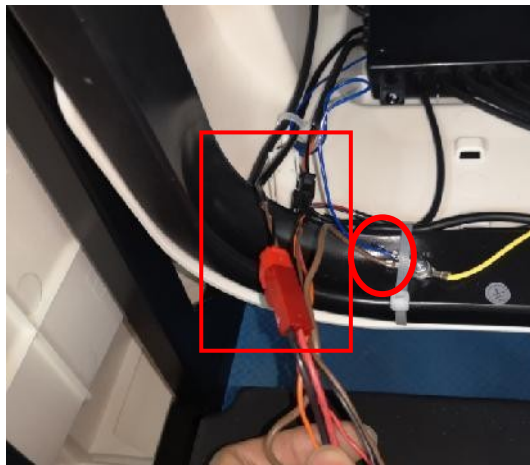

5.Unplug the terminal, remove 1 screw, and take off the ground wire



6 backrest cable

15、 disassembly of gear box :

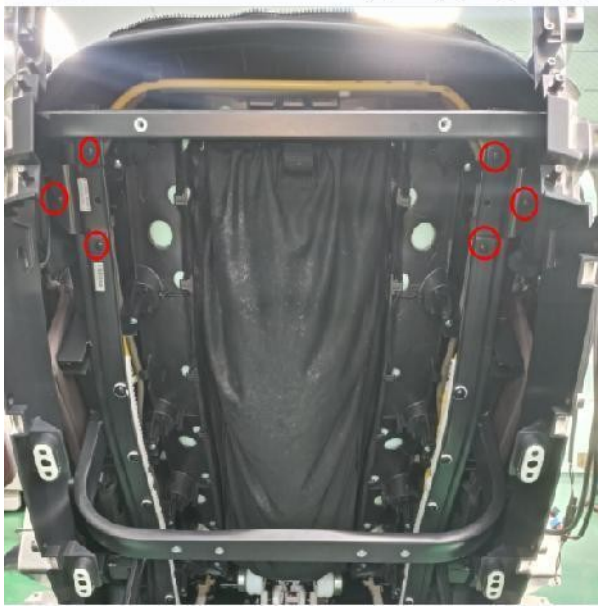

1 remove 6 screws

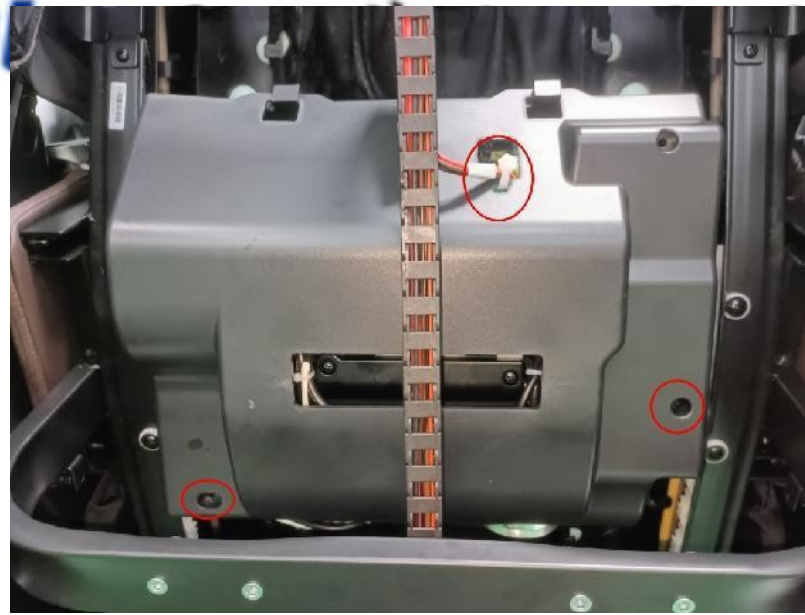

2 Remove two screws, cut the cable tie, and take off the protective cover



3 Unplug the terminal, remove the ground wire, and cut the cable tie



4 Connect the red terminal to an external 24V power supply to move the gear box up and down for removal

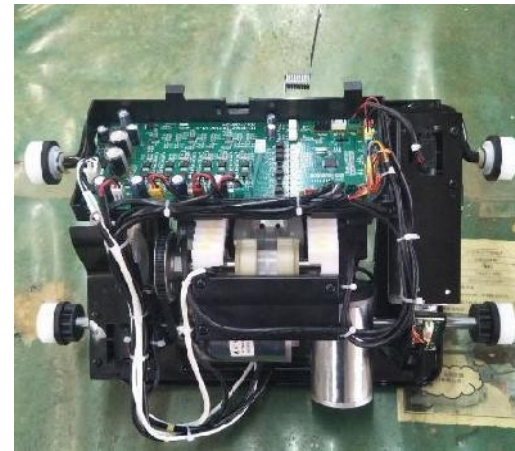

5 gear box

16、 disassembly of main PCB box:main PCB



1.remove 3 screws , remove the cover of the main PCB box



2.main PCB box



3.cover of the main PCB box



4.main PCB

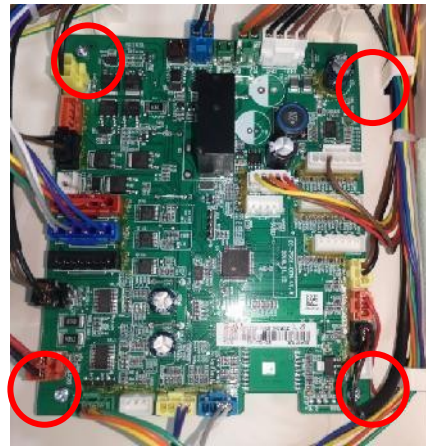

5.Disconnect the terminals of the main PCB and remove 4 screws



6.main PCB

16.1 disassembly of main PCB box:power PCB

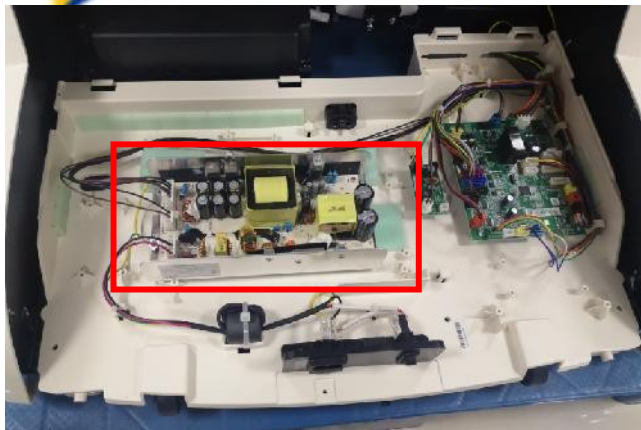

1.power PCB



2.remove 5 screws



3.power PCB



EASEPAL

厦门蒙发利电子有限公司客户服务部

17、disassembly of backrest actuator :

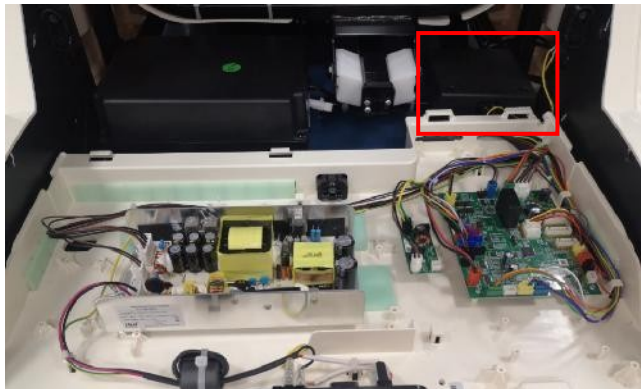

A.switch box



B.open the box

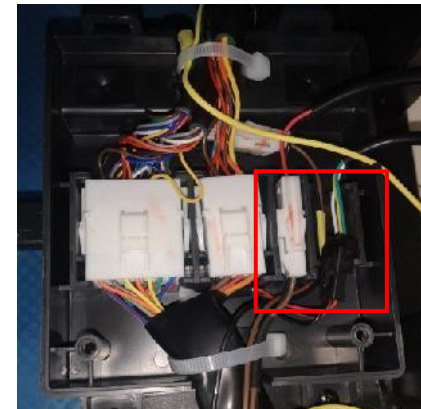

C.disconnect the terminals



D.remove 4 screws



E.cut cable , remove the shaft

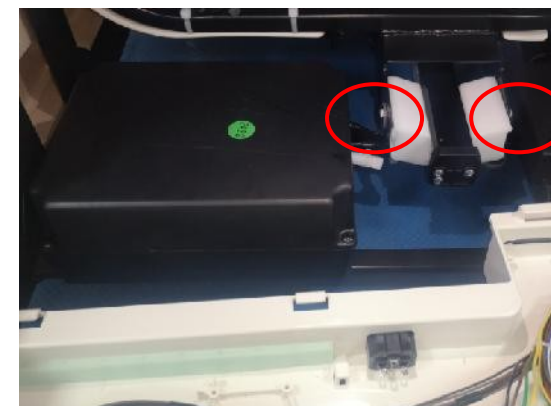

F.remove 2 screws



18、 disassembly of legrest actuator :



A.cut cable tie

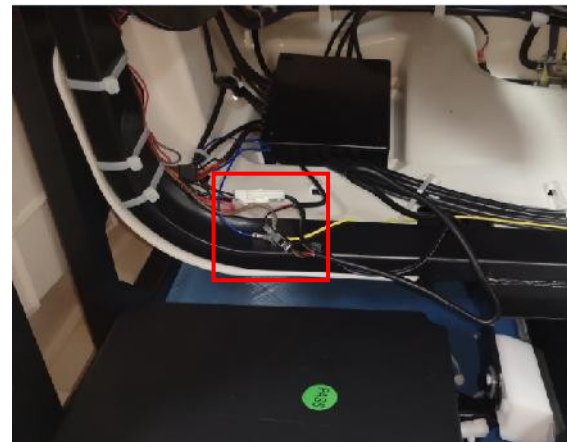

B.disconnect the terminals



C.take down the shaft



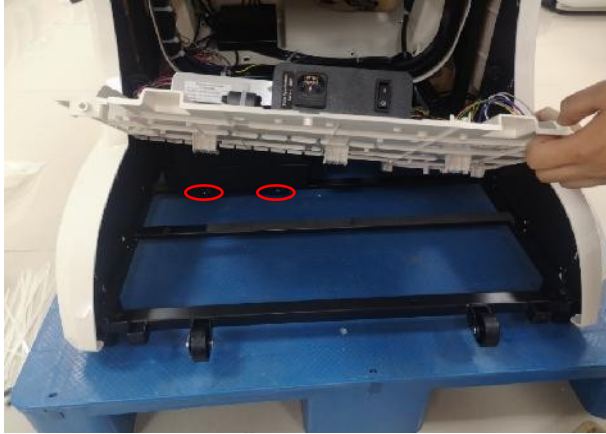

A.remove 2 screws



B.cut cable tie , disconnect the terminal

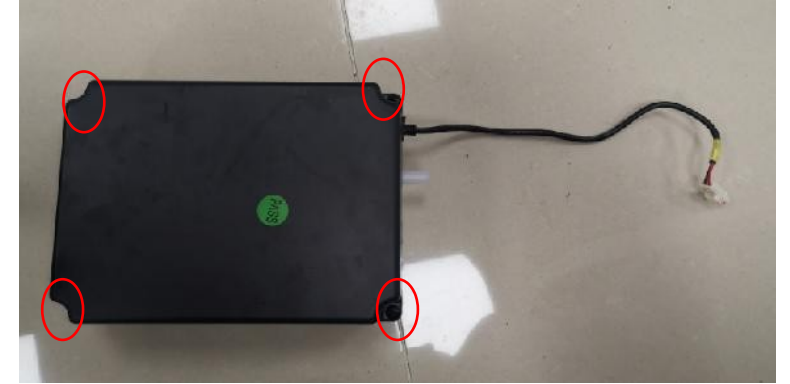

C.remove 4 screws



D.open the box

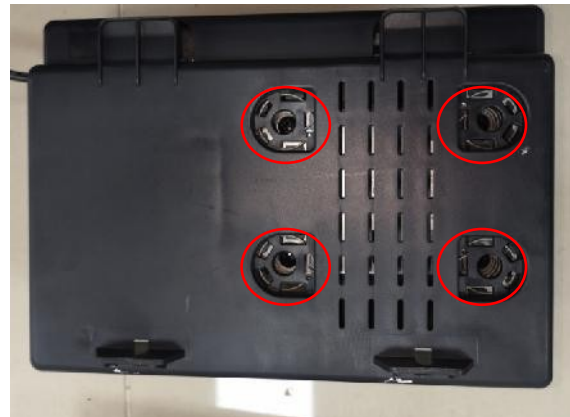

E.remove 4 screws



F.air pump



EASEPAL

厦门蒙发利电子有限公司客户服务部

20、disassembly of the legrest :



1.unzip the zipper



2.Remove the blocking on both sides of the legrest



3.disconnect the terminal and air hose



EASEPAL

厦门蒙发利电子有限公司客户服务部

21、disassembly of the upper legrest:(remove the legrest first)



1.extend the legrest



2.unzip the zipper

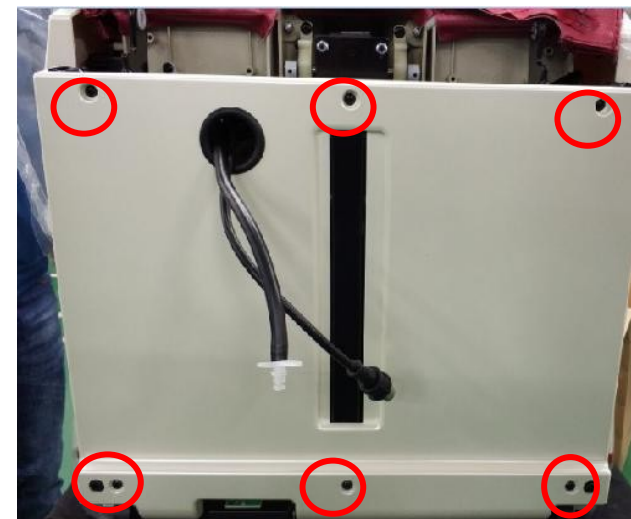

3.remove the screws

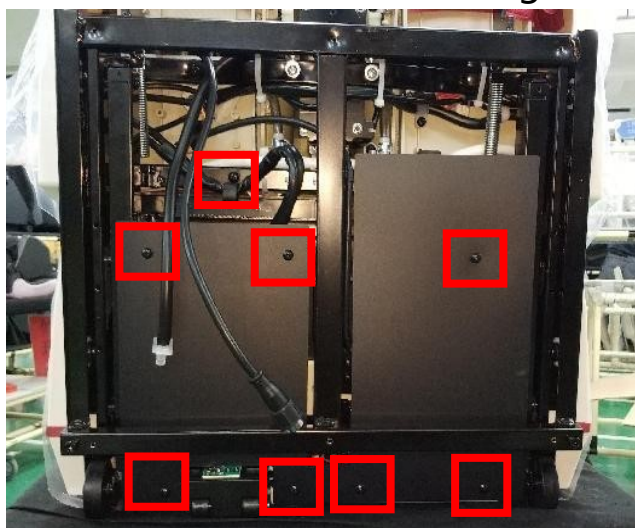

4.remove the screws

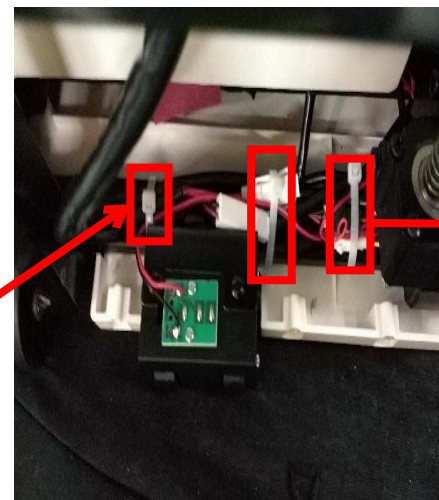
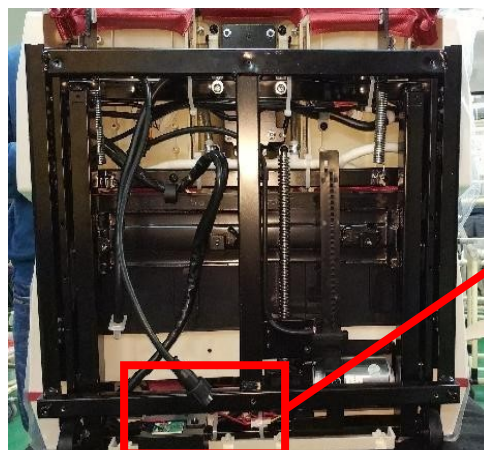

5.Cut off the cable tie

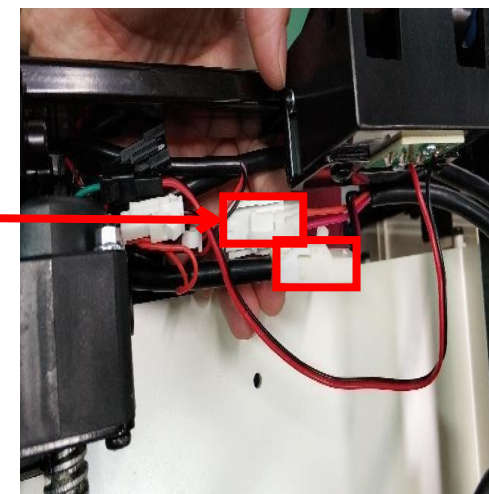

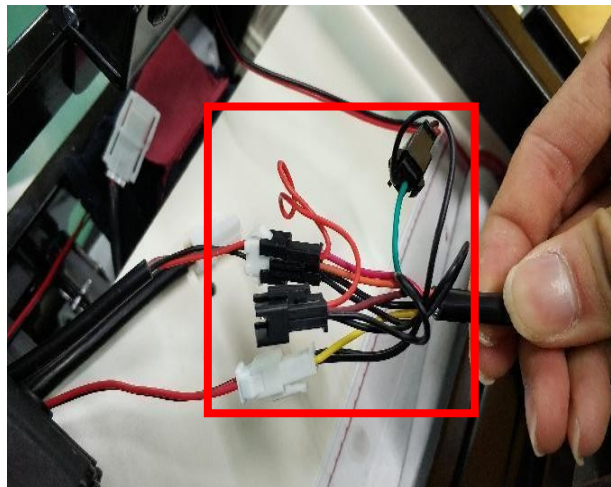

6.Unplug the terminal

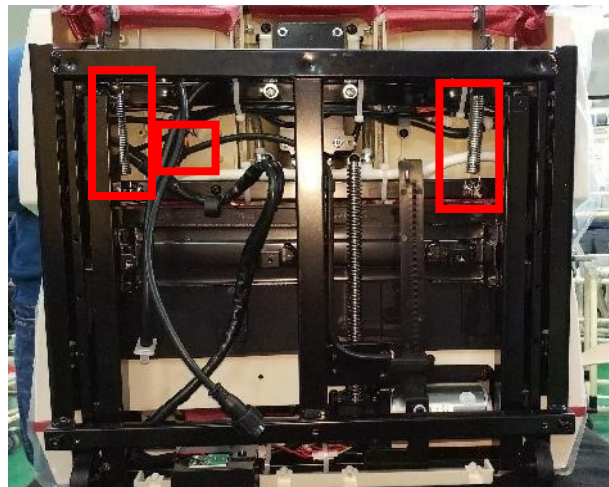

7.Remove the spring

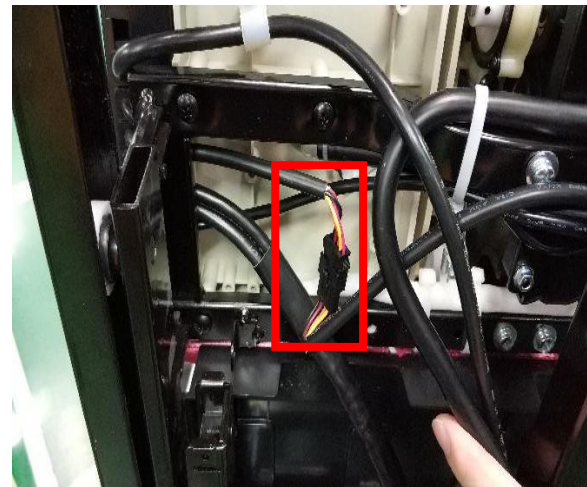

8.Unplug the terminal

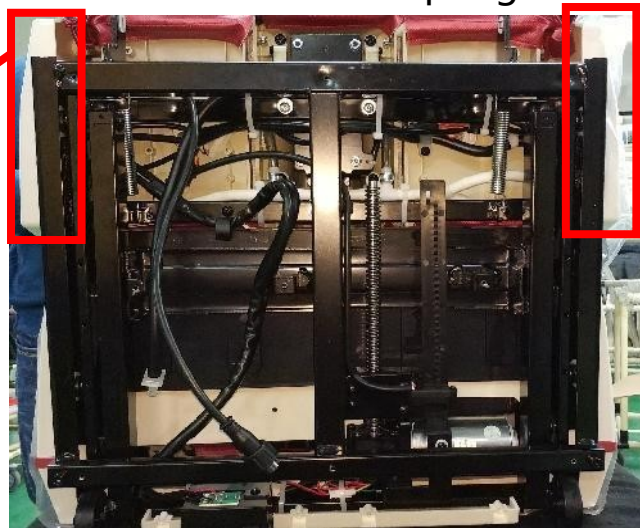
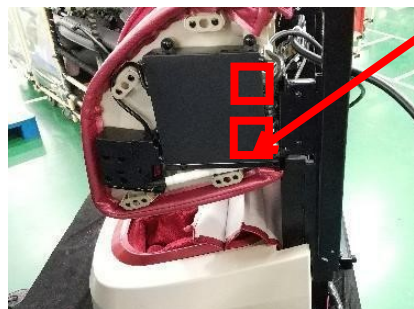

9.remove the screws

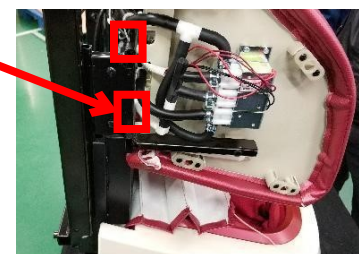

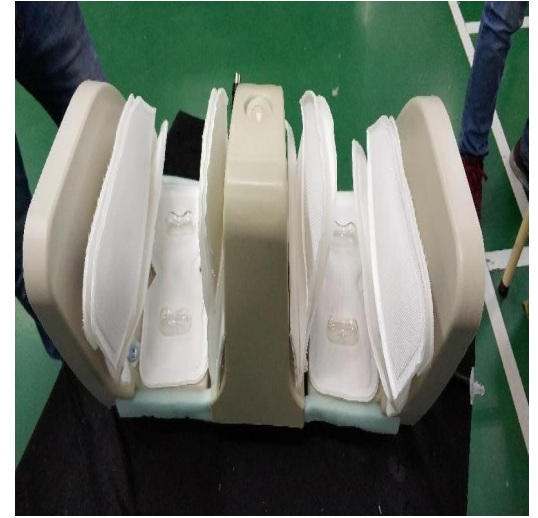
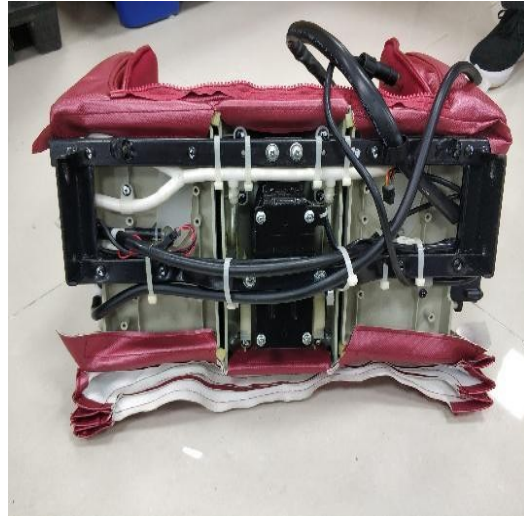

10. Tear off the sticky fur buckle to replace the upper legrest leather cover



11. remove the screws



12. Unplug all the air hose to replace all the airbags

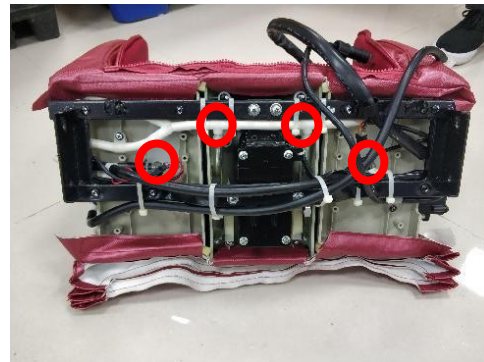



EASEPAL

厦门蒙发利电子有限公司客户服务部

22、 disassembly of legrest PCB



1. Prise open the left side decorative cover of the upper legrest



2. remove the screws

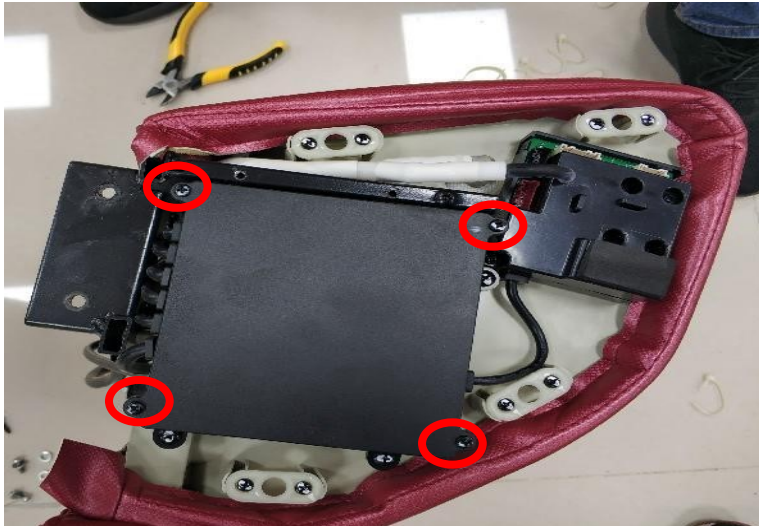

3. remove the screws

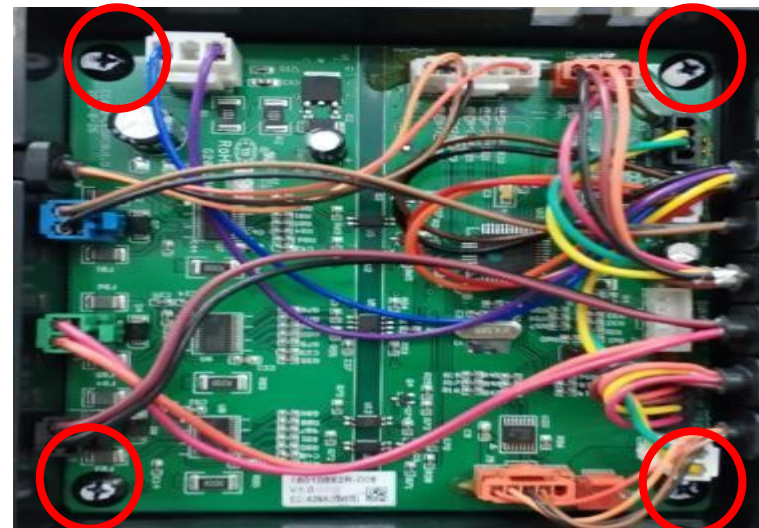

4. remove the screws and unplug all the terminals



EASEPAL

厦门蒙发利电子有限公司客户服务部

23、 disassembly of legrest air valve: (remove the legrest first)



1. Prise open the left side decorative cover of the upper legrest

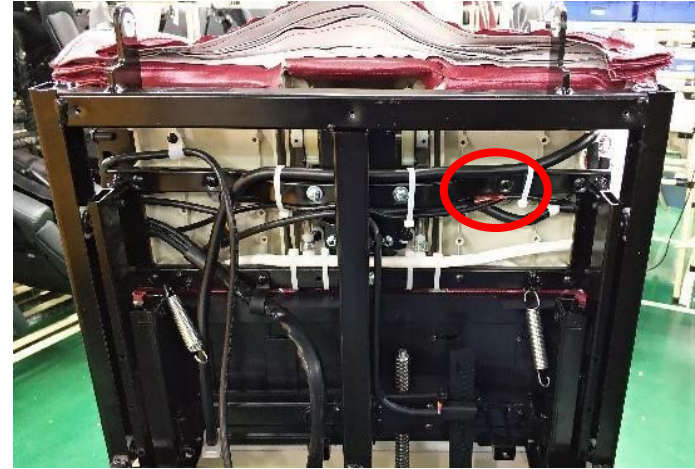

2. Cut off the cable tie and disconnect the air valve connection line

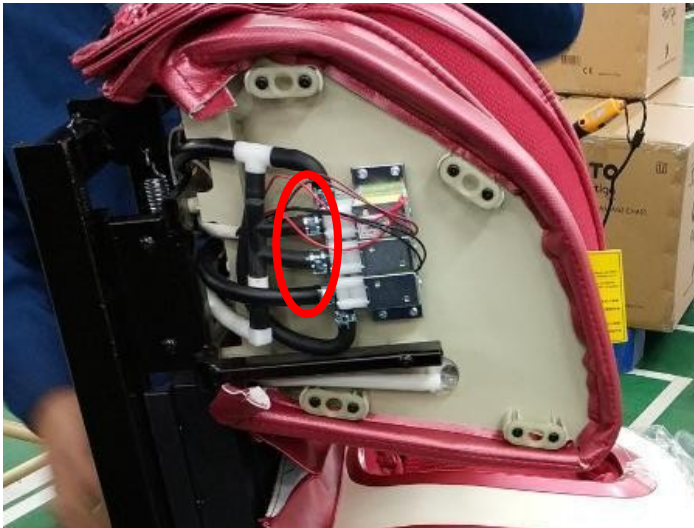

3. Use needle-nose pliers to remove the metal cable tie and then unplug the air hose

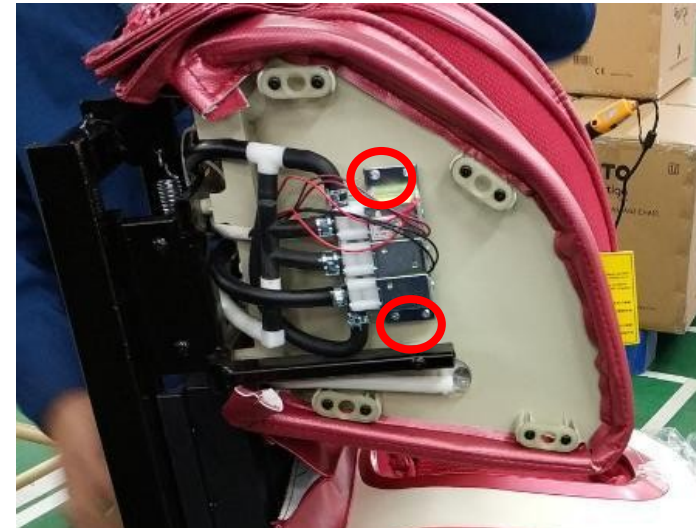

4. remove the screws



EASEPAL

厦门蒙发利电子有限公司客户服务部

24、disassembly of foot massage:remove the legrest first



1. extend the legrest



2.unzip the zipper

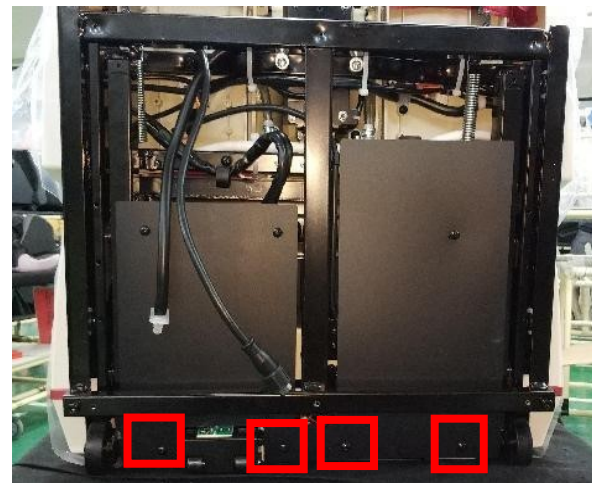

3.remove the screws



4.remove the screws

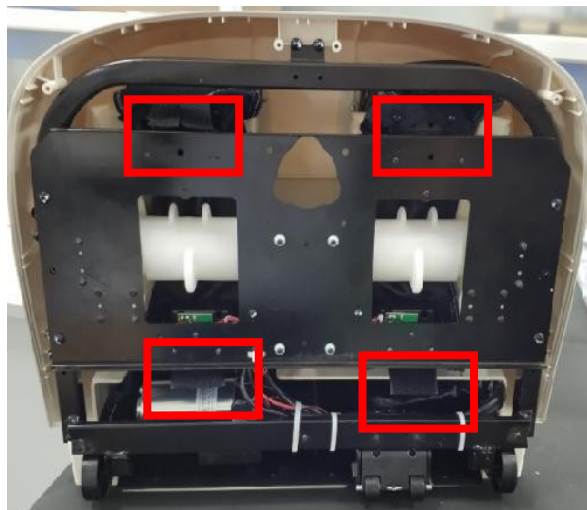

5.remove the screws

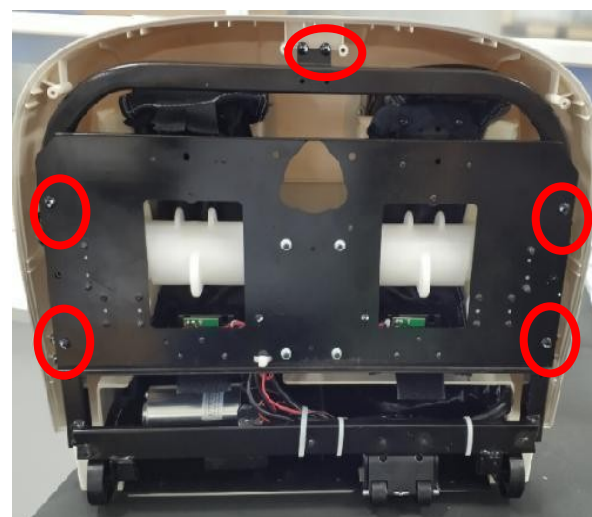

6. remove 6 screws

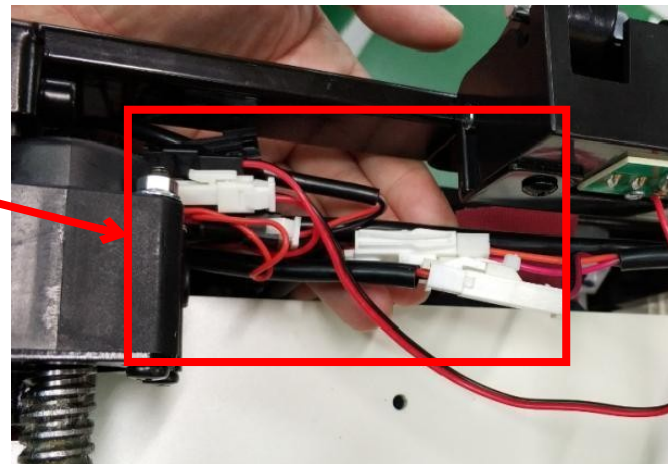
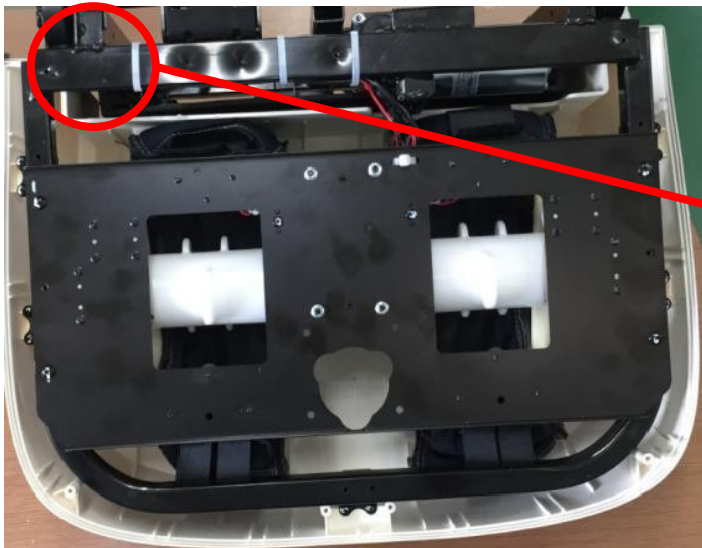

7 cut off the cable tie, disconnect the connection line

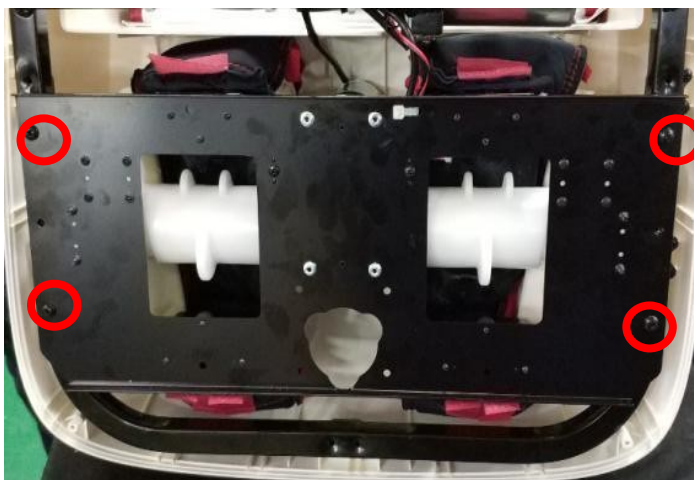

8.remove the screws

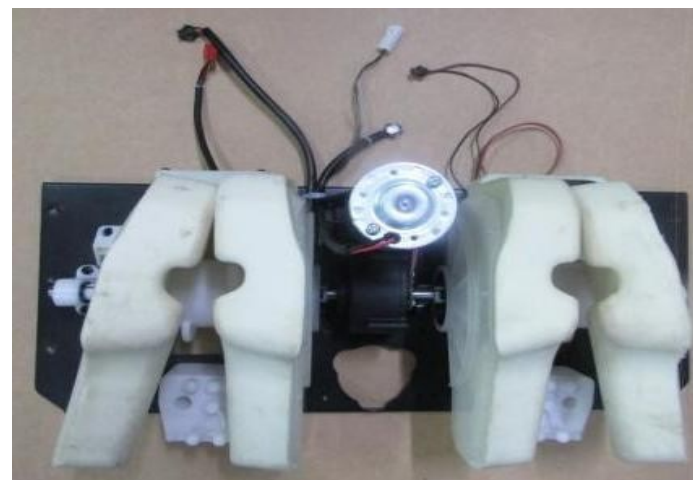

9.foot massage



EASEPAL

厦门蒙发利电子有限公司客户服务部

25、disassembly of the under seat
PCB :



A.unzip the zipper



B.under seat PCB box and air valve

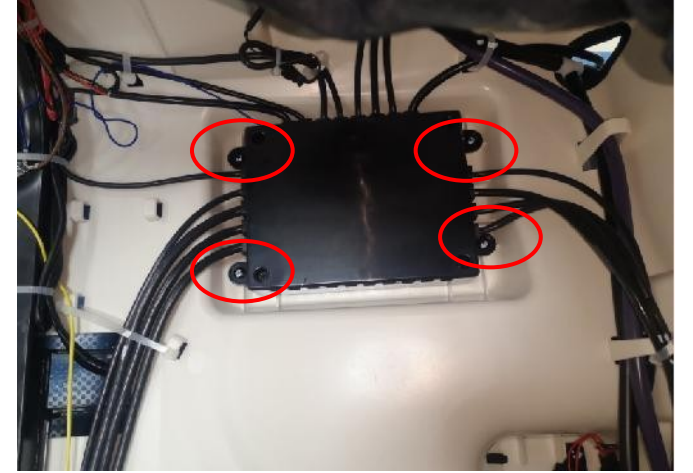

C.remove 4 screws

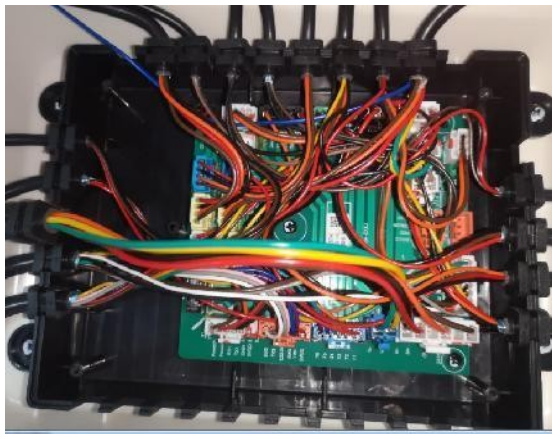

D.under seat PCB

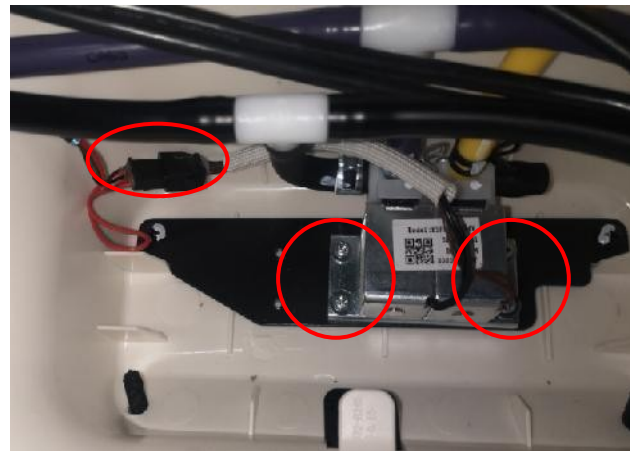

F.disconnect the terminal and
remove 4 screws



G.air valve(under seat)



EASEPAL

厦门蒙发利电子有限公司客户服务部

5、Massage chair fault judgment

OPEN:

[0xE0]auto

Setting

Language: English, Deutsch, Français, Español, Русский

Touch volume

Screen sleep: 0, 5, 10, 15, 25, 30 Min

Screen brightness

在设置页面屏幕最下方长按数秒,将弹出工程模式密码输入页面

project_version

Status !

[0xE0] auto	[0xE6] No time	[0xEC] info
[0xE1] manual	[0xE7] spike	[0xED] other 1
[0xE2] packing	[0xE8] age	[0xEE] other 2
[0xE3] check 1	[0xE9] test 1	[0xEF] other 3
[0xE4] check 2	[0xEA] test 2	disable error
[0xE5] check 3	[0xEB] test 3	tp corrdinate

Log:



5、 Massage chair fault judgment

【 Testing process 】

Backrest actuator: back to the lowest -- > up to the highest

legrest actuator: up to the highest -- > down to the lowest

legrest extension: extend -- > retract

mechanism up and down: down to the lowest -- > up to the highest

mechanism 3D expansion: strongest -- > weakest

mechanism width: narrowest -- > widest

mechanism knocking: knock all the time first, and then stop knocking after the above steps are completed

Air pump: normally open

Air valve: open 2S -- > Close 2S and keep cycling.

mechanism heating: always on.

Projector: always on.

Logo light: always on.

leg kneading: keep it open.

Foot kneading: keep it open.



No.	problem description	steps of shooting the trouble	steps of shooting the trouble	remark
1	remote control tested any key pressed more than 40 seconds	one of the KEY has been blocked	Detect remote control buttons	turn on the chair
2	remote control did not connected more than 4 seconds	1.remote control wire is broken or the remote control is disconnected	1.reconnecte the remote control or change the remote control wire.	turn on the chair
3	backrest signal is abnormity	1.backrest wire is not well connected. 2.backrest wire is broken	1.check whether the backrest wire is well connected 2.change the backrest wire	turn on the chair
5	Side panel controller tested any key pressed more than 45 seconds	1.one of the KEY has been blocked.	1.check remote control or side panel controller	enter auto-check model
6	leg rest tested more than 4 seconds	1.connector of leg rest wire not well 2.wire of leg rest broken	1.check the connector of leg rest wire 2.change the wire of leg rest	enter auto-check model
32	Side panel controller fails to communicate with main PCB more than 4S	connector of wire not well	1.check the connector of wire 2.change the wire	enter auto-check model



40	The position sensor of the rolling motor is abnormal, no change of the position code disk is detected after 8s.	<ol style="list-style-type: none"> 1. Position sensor is broken 2. The connection between the main PCB and the 3D PCB is abnormal 3. rolling motor is broken or locked 4. Drive circuit components are damaged 	<ol style="list-style-type: none"> 1. change the sensor 2. check the wire 3. check or change the motor 4. change main PCB 	enter auto-check model
41	The position coding of rolling motor is abnormal , the code disk is in an incorrect position	<ol style="list-style-type: none"> 1. position sensor broken 2. Incorrect initial position of code disk 2. mechanism overshoot 	<ol style="list-style-type: none"> 1. change the sensor 2. the mechanism to the initial height position, and then turn the code disk to the correct initial position. 	enter auto-check model
42	The rotation speed sensor of the core massage (rolling) motor is abnormal, that is, no change of the rotation speed code disk is detected more than 4S.	<ol style="list-style-type: none"> 1. position sensor is broken 2. The connection between the main PCB and the 3D PCB is abnormal 3. motor is broken or locked 4. Drive circuit components are damaged 	<ol style="list-style-type: none"> 1. change the sensor 2. check the wire 3. check or change the motor 4. change main PCB 	enter auto-check model
44	The position sensor of the core kneading motor is abnormal, that is, no change of the position code plate is detected after 8s.	<ol style="list-style-type: none"> 1. position sensor is broken 2. The connection between the main PCB and the 3D PCB is abnormal 3. motor is broken or locked 4. Drive circuit components are damaged 	<ol style="list-style-type: none"> 1. change the sensor 2. check the wire 3. check or change the motor 4. change main PCB 	enter auto-check model



EASEPAL

5、Massage chair fault judgment 厦门蒙利电子有限公司客户服务部

46	The rotation speed sensor of the core kneading motor is abnormal, that is, no change of the rotation speed code disk is detected after 5S.	1. position sensor is broken 2. The connection between the main PCB and the 3D PCB is abnormal 3. motor is broken or locked 4. Drive circuit components are damaged	1. change the sensor 2. check the wire 3. check or change the motor 4. change main PCB	enter auto-check model
48	The position sensor of the core expansion motor is abnormal, i.e. no change of the position code disk is detected after 10s.	1. position sensor is broken 2. The connection between the main PCB and the 3D PCB is abnormal 3. motor is broken or locked 4. Drive circuit components are damaged	1. change the sensor 2. check the wire 3. check or change the motor 4. change main PCB	enter auto-check model
49	The position coding of the core expansion motor is abnormal, that is, the code disk is in an incorrect position.	1. position sensor is broken 2. Incorrect initial position of code disk 2. mechanism overshoot	1. change the sensor 2. Move the mechanism to the initial retraction position	enter auto-check model
50	Abnormal rotation speed (count) sensor of core expansion motor	1. position sensor is broken 2. The connection between the main PCB and the 3D PCB is abnormal 3. motor is broken or locked 4. Drive circuit components are damaged	1. change the sensor 2. check the wire 3. check or change the motor 4. change main PCB	enter auto-check model



EASEPAL

5、Massage chair fault judgment 厦门荣发利电子有限公司客户服务部

59	backrest Count sensor abnormal	<ol style="list-style-type: none"> 1. count sensor broken 2. the wire is broken 3. motor is broken or locked 4. Drive circuit components are damaged 	<ol style="list-style-type: none"> 1. change the sensor 2. check the wire 3. check or change the motor 4. change main PCB 	enter auto-check model
63	leg rest Count sensor abnormal	<ol style="list-style-type: none"> 1. count sensor broken 2. the wire is broken 3. motor is broken or locked 4. Drive circuit components are damaged 	<ol style="list-style-type: none"> 1. change the sensor 2. check the wire 3. check or change the motor 4. change main PCB 	enter auto-check model
68	Calf extension position (count) sensor abnormal	<ol style="list-style-type: none"> 1. count sensor broken 2. the wire is broken 3. motor is broken or locked 4. Drive circuit components are damaged 	<ol style="list-style-type: none"> 1. change the sensor 2. check the wire 3. check or change the motor 4. change main PCB 	enter auto-check model
69	Abnormal coding of crus extension position (the shortest and longest limit sensors are valid at the same time)	<ol style="list-style-type: none"> 1. position sensor broken 2. wire broken 	<ol style="list-style-type: none"> 1. change the sensor 2. check the wire 	enter auto-check model
70	Calf extension shortest limit sensor failure	<ol style="list-style-type: none"> 1. position sensor broken 2. wire broken 	<ol style="list-style-type: none"> 1. change the sensor 2. check the wire 	enter auto-check model



EASEPAL

5、Massage chair fault judgment 厦门蒙发利电子有限公司客户服务部

71	Calf extension longest limit sensor failure	1.position sensor broken 2.wire broken	1.change the sensor 2.check the wire	enter auto-check model
72	The back heating thyristor is short circuited, i.e. the temperature is greater than or equal to 78 degrees detected for 10s.	The heating wire is short circuited and caused by overcurrent.	(1)check or chuange the heater (2)Check whether the back frame wire and the heating of the core are short circuited and replace if there is any problem.	enter auto-check model
73	The back heating thermistor is short circuited, i.e. the AD detection value is less than or equal to 5 in 5S.	Heating thermistor wire short circuit to ground	Check whether the back frame wire and the heating of the core are short circuited and replace if there is any problem.	enter auto-check model
74	The back heating thermistor has an open circuit, that is, the ad detection value is greater than or equal to 247 in 5S.	Heating thermistor wire disconnected	Check whether the back frame wire and the heating of the movement are open circuit, and replace if there is any problem.	enter auto-check model