

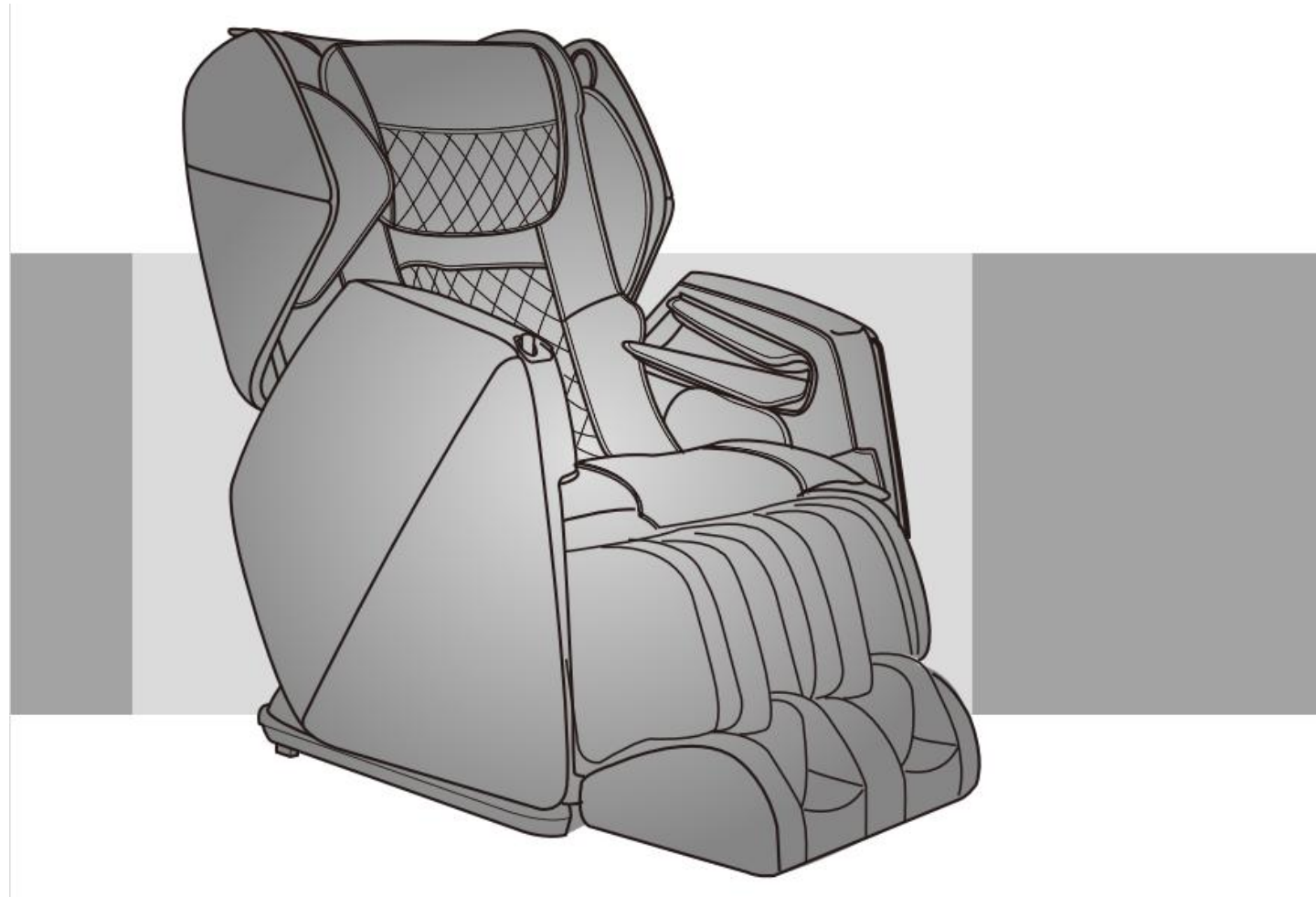

**EASEPAL** 厦门蒙发利电子有限公司客户服务部

# EC-626E massage chair service





## Table of Contents

- 一、 Product introduction**
- 二、 Massage chair tools and use**
- 三、 Circuit working principle**
- 四、 Massage chair removal instructions**
- 五、 Massage chair fault judgment**



## 一、Product introduction

### Chair Components

Front

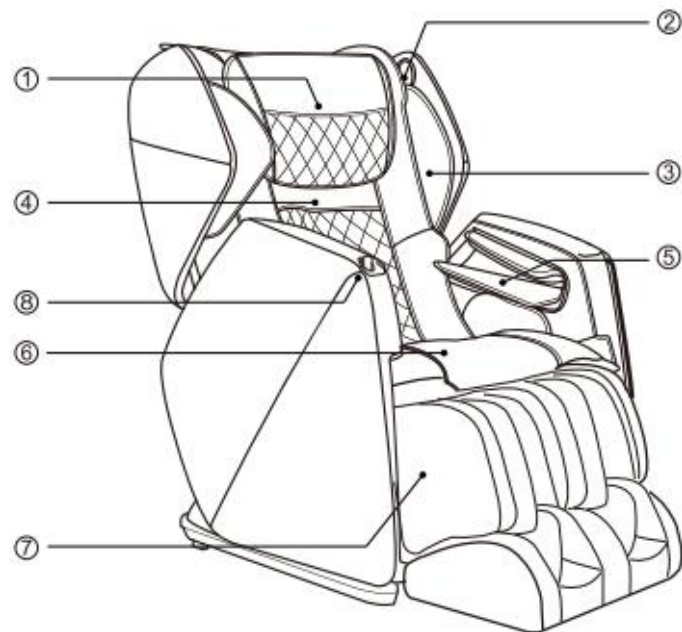

① Pillow Pad

③ Shoulder side massage section

⑤ Hand and arm massage section

⑦ Legrest

② Bluetooth Speaker (See Page 5)

④ Backrest Pad

⑥ Seat

⑧ Controller Storage Compartment



**EASEPAL**

厦门蒙发利电子有限公司客户服务部

Air Massage Area

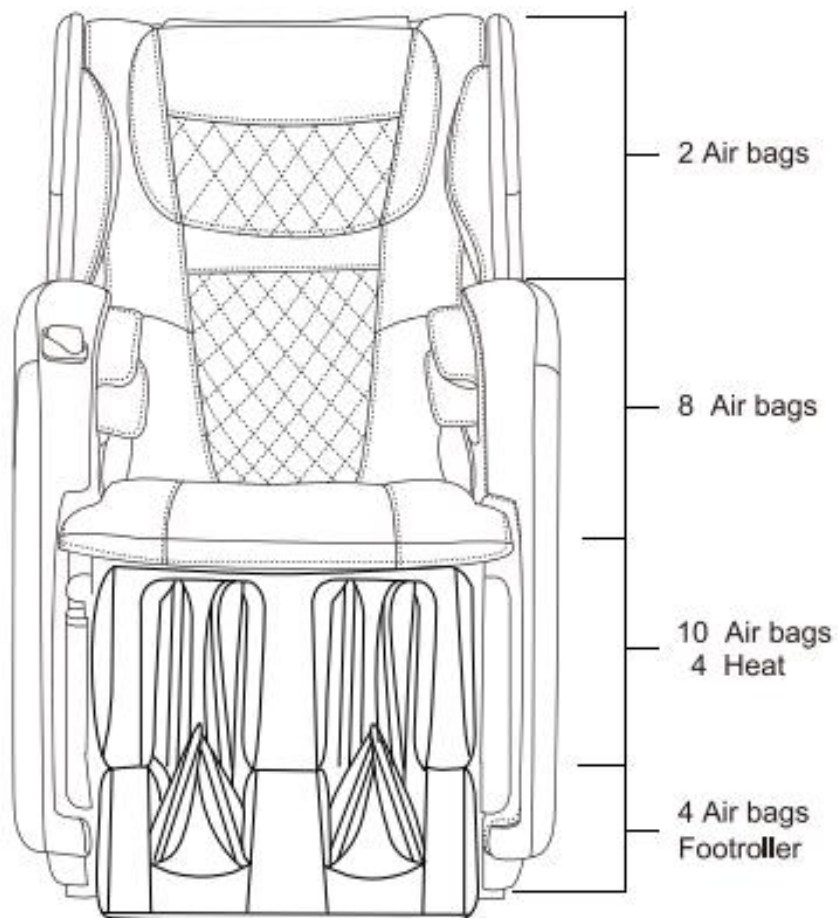



### Chair Specifications

Description	Specifications
Model No.	OS-Pro Soho II
Rated Voltage	110V~120V
Rated Frequency	60Hz
Rated Power Consumption	260W
Timer	5/10/15/20/25/30 minutes
Rated Time	15 minutes
Dimensions(L x W x H)	Upright: 57.48"x29.53"x44.88"
	Reclined: 64.96"x29.53"x42.52"
Weight	Gross Weight: Approx. 245.82 lbs
	Net Weight: Approx. 205.03 lbs
Length of Wire	Controller wire: 59.0"
	Power supply wire: 70.9"
Usage Condition	Environment temperature: 32°F~95°F
	Contrasting humidity: 20-80RH
Storage Condition	Storage temperature: 23°F~95°F
	Storage humidity: 20-80RH
Safety Feature	Equipped with overheated and power
Maximum body weight of user	220 lbs



EASEPAL

厦门蒙发利电子有限公司客户服务部

## 二、Massage chair tools and use

### 1.tools

					
Screwdriver size 1,2,3	Diagonal cutter and long nose pliers	Soldering Kit	Spanner tools Kit	Test pen	Allen Key set
					
Ratchet Tools Set	24V/DC power	Electric Driver	electrical adhesive tape	Cable Ties	WIRE ONECTORS



## 2.Usage of multimeter

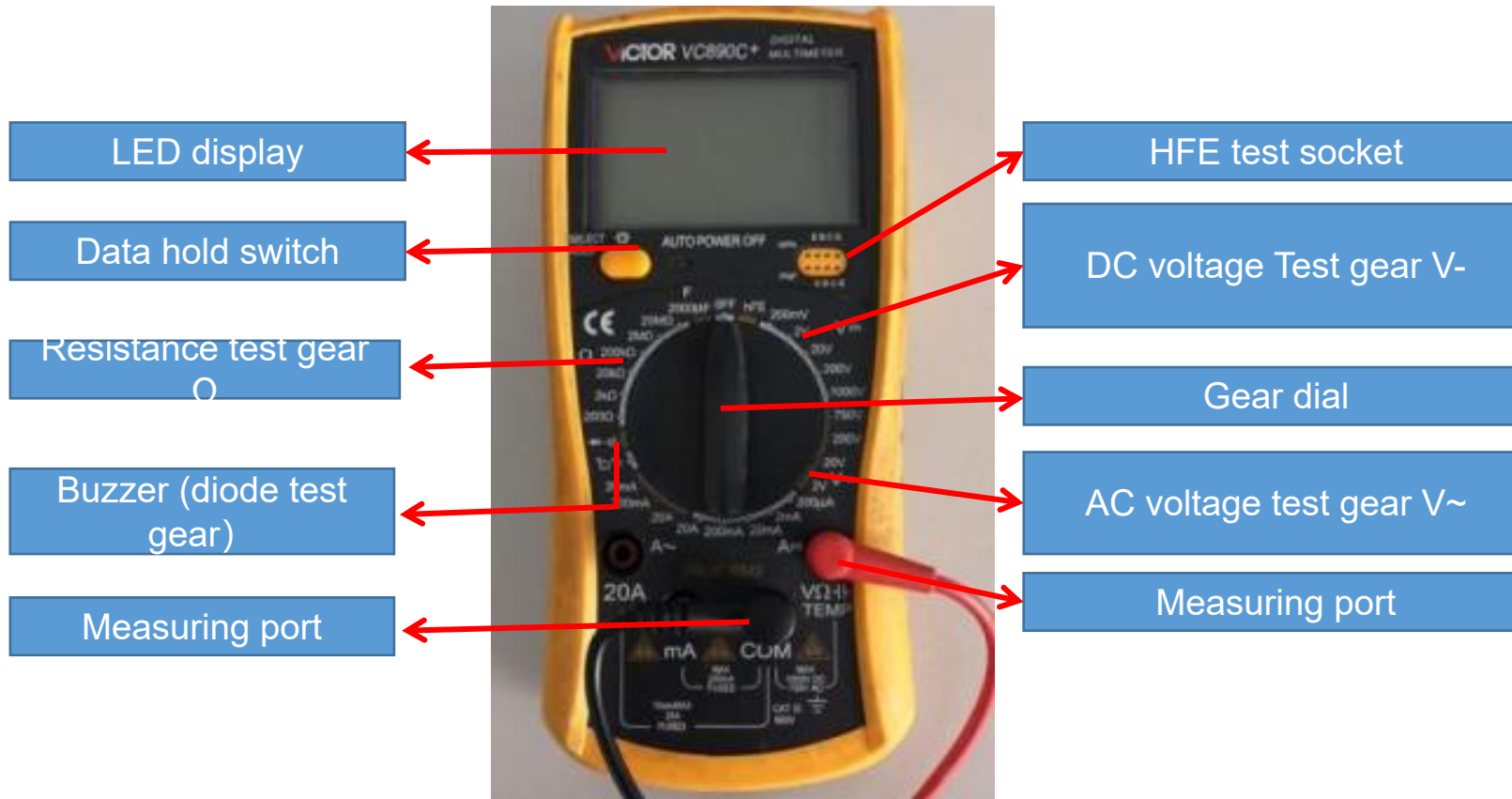



## 2.1、 Function of the test gears

**Data hold switch**: Memorize the measured data for comparison。

**Buzzer (diode test gear)** : Measure the quality of diode, the on-off and alarm function of circuit

**Resistance gear test gear**: Measure the quality and value of resistance

**DC voltage Test gear V-**: Measure DC voltage

**AC voltage test gear V~**: Measure AC voltage

**VΩ / COM**: VΩ Red pen port (+ pole) during test, black pen port (- pole) during com test

**Note**: when carrying out resistance or voltage test, it is necessary to select a suitable range. If the range is too small to be measured, and the range is too large, the test error range is large; if the voltage is not known, it is necessary to select a range measurement with a large windlass.





## 2.2、 On / off measurement of lines



open circuit



As shown in the left picture, first set the multimeter to the buzzer and power it  
When the switch is on, the multimeter will display "0."; then contact the two probes with the ends of the red wire  
At this time, the multimeter still shows "1." there is no change, which means there is an open circuit in the middle of the wire, that is, the line is open.



close circuit



As shown in the picture on the left, if the multimeter shows the number of ". 002" or ". 00n" and gives an alarm, it means that the wire is connected.



### 2.3、 Measurement of AC voltage



As shown in the picture above: measure the household plug-in board power supply (220V), select the range of 750, and the test result shows "224", indicating that the actual voltage of this group of sockets is 224v at the moment (the switch is pressed down, so there is power, and the light is

or



As shown in the above picture: measure the power supply (220V) of our household plug-in board, select the range of 750, and the test result is displayed as "001", indicating that the actual voltage of this group of sockets is 0V at the moment (the switch is not pressed down, so there is no power, and the light is not on).

## 2.4、 DC voltage measurement



As shown in the picture above: the test result is "1.58", indicating that the voltage at both ends of the battery is 1.58v, and the red lead is connected to the "+" pole of the battery, and the black lead is connected to the "-" pole of the electromagnetic.



As shown in the above picture: the test result is "- 1.58", indicating that the voltage at both ends of the battery is 1.58v, and the red lead is connected to the "-" pole of the battery, and the black lead is connected to the "+" pole of the electromagnetic



### 三、Circuit working principle

#### 1、main PCB:

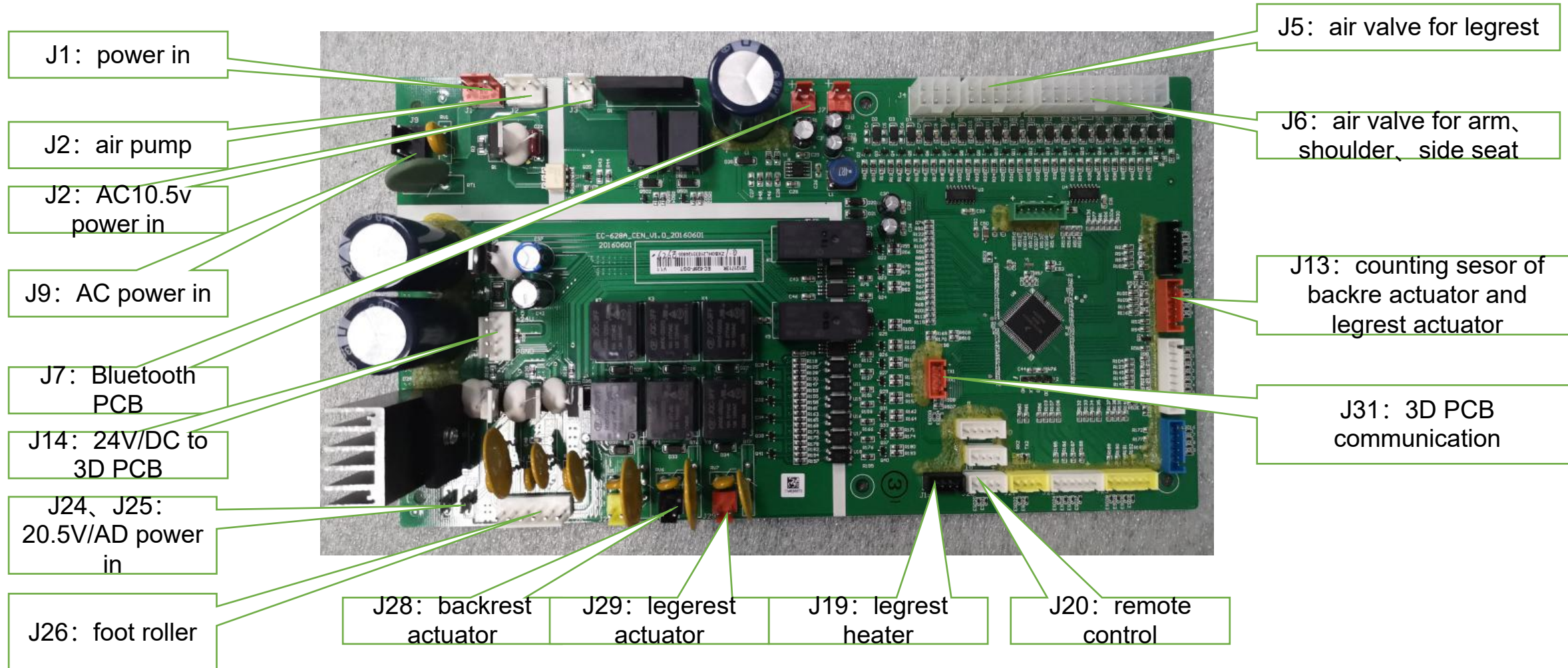



## 2、3D PCB

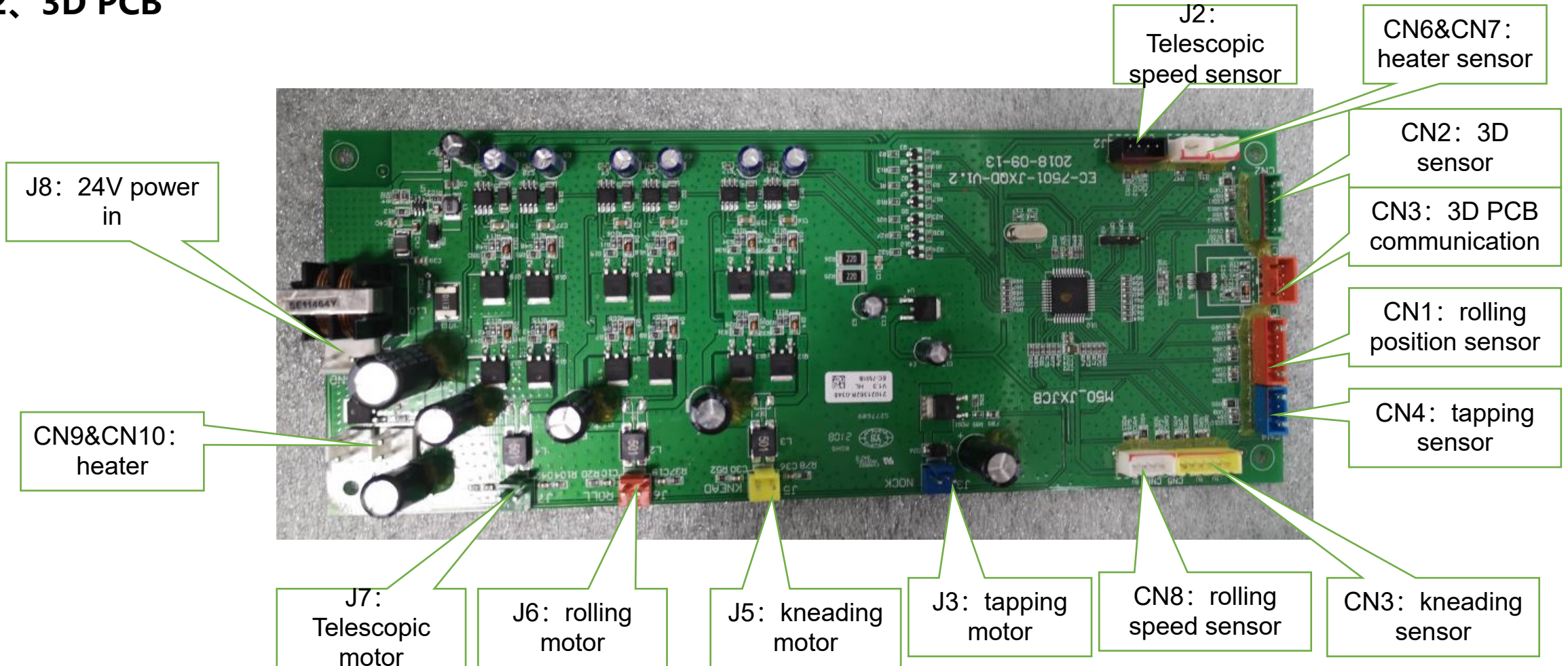

1、 Internal structure diagram(main PCB box):

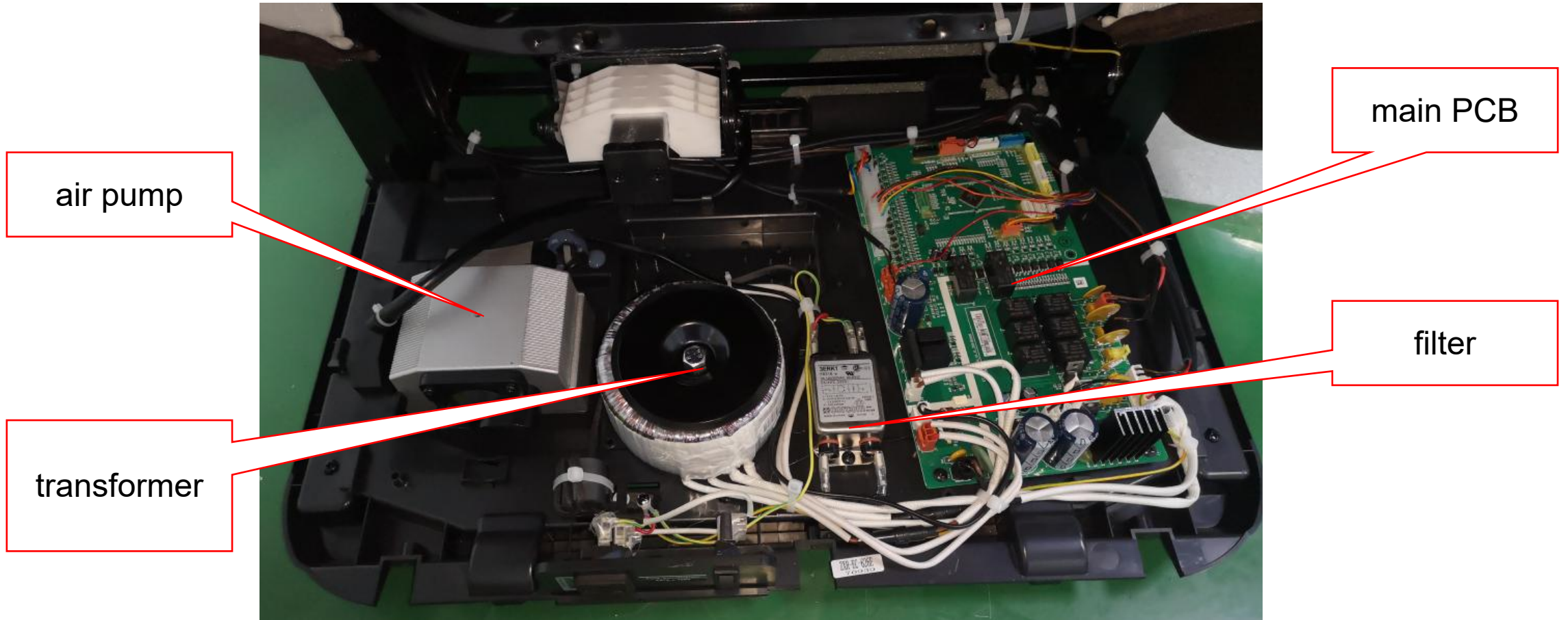



2、 Internal structure diagram (legrest) :

1

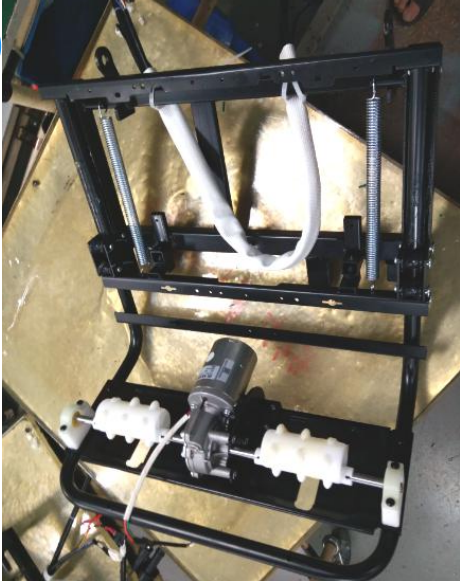

Legrest hardware and foot roll assembly



Legrest



upper legrest



lower legrest

### 3.1、 Disassembly of the pillow:



unzip the zipper, remove the pillow



pillow





### 3.2、 Disassembly of the backrest pad



unzip the zipper



Untie the 2 Sticky wool buttons



unzip the zipper



unzip the zipper



backrest pad



### 3.3、 Disassembly of the side panel:



force the cover with the hands



lower cover



upper cover



force the cover with the hands



lower cover



upper cover

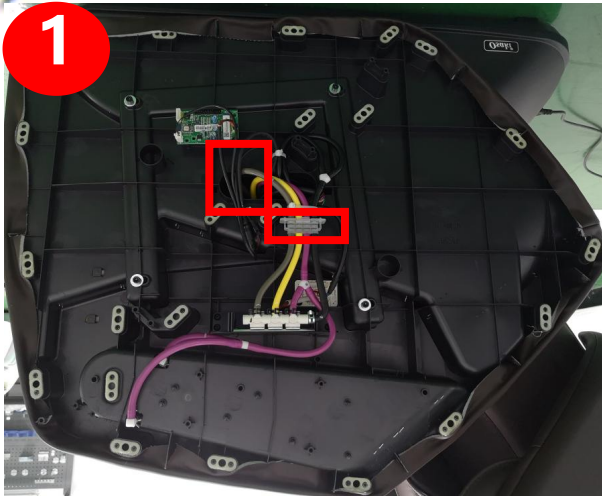

disconnected the air hose and terminals

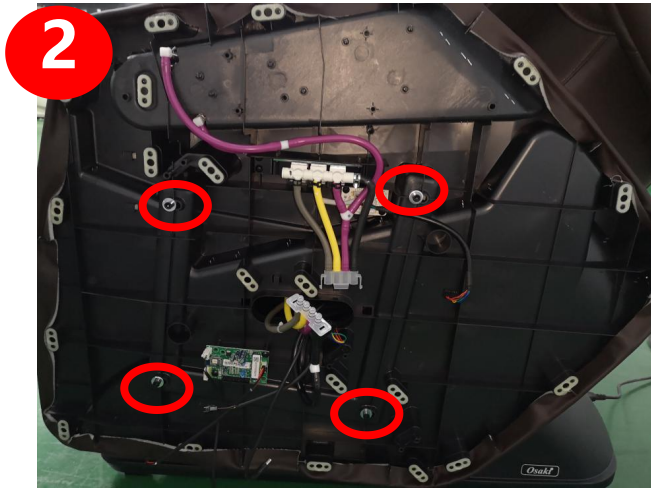

remove 4 screws



left side panel

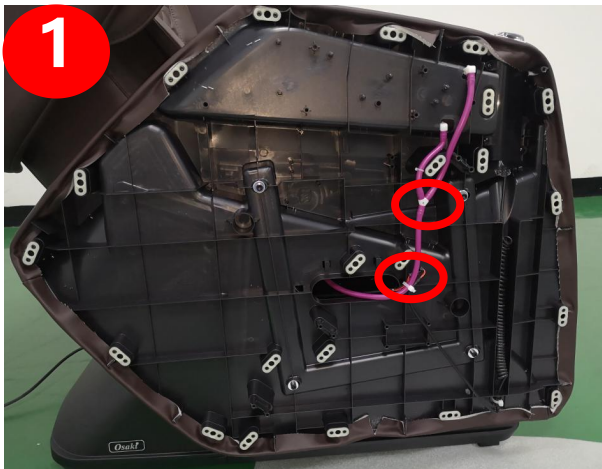

disconnected the air hose and terminals

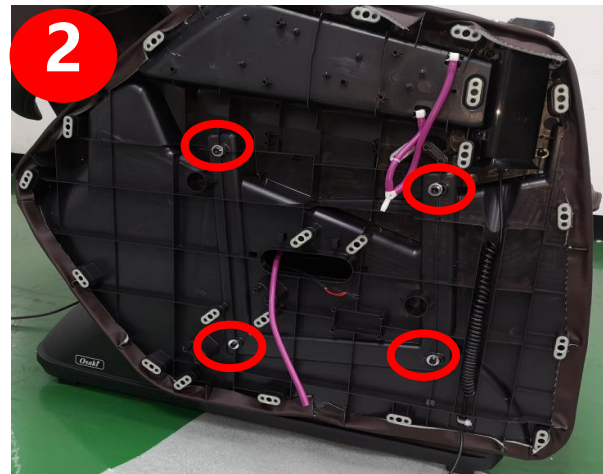

remove 4 screws



right side panel



EASEPAL

厦门蒙发利电子有限公司客户服务部



unzip the zipper



remove the cover

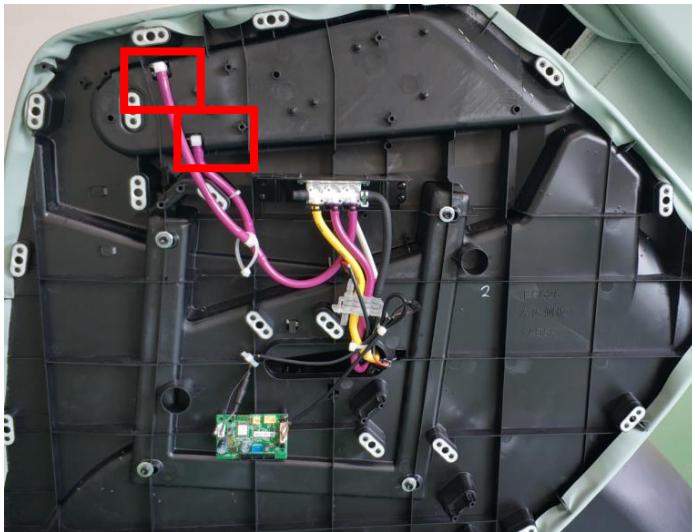

disconnected the air hose



remove the screws



arm air bag

**3.4、 disassembly of inner side panel: Bluetooth PCB、 air valve**

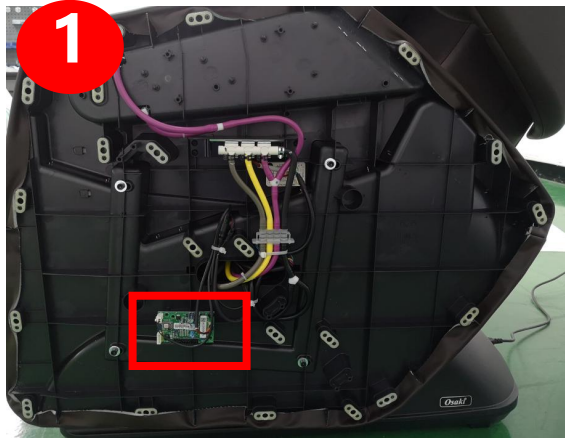

1

Bluetooth PCB



2

disconnected the terminals and remove 4 screws



3

remove the Bluetooth PCB

1

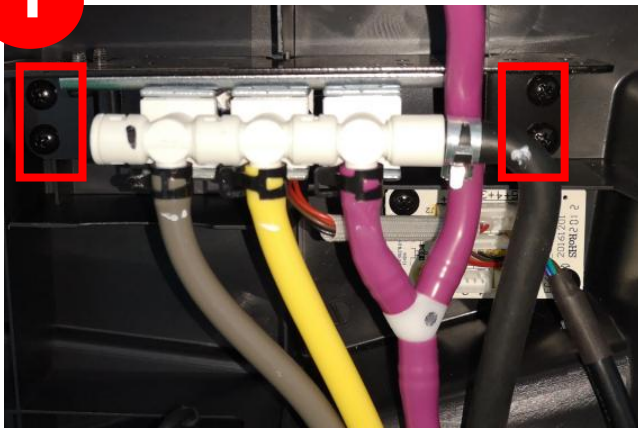

remove 4 screws and disconnected the terminal and air hose

EC-626E massage chair service

2

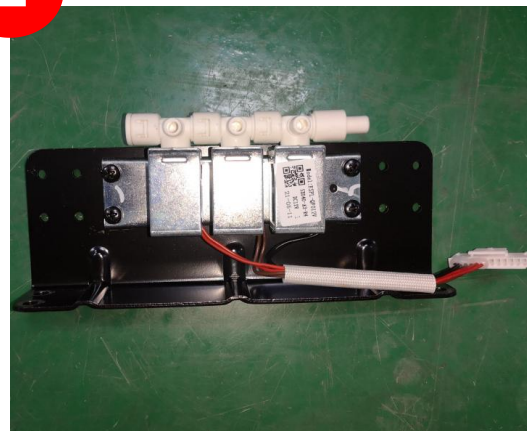

remove 4 screws

3



remove the air valve



3.5、 disassembly of inner side panel: remote control box remote control

1

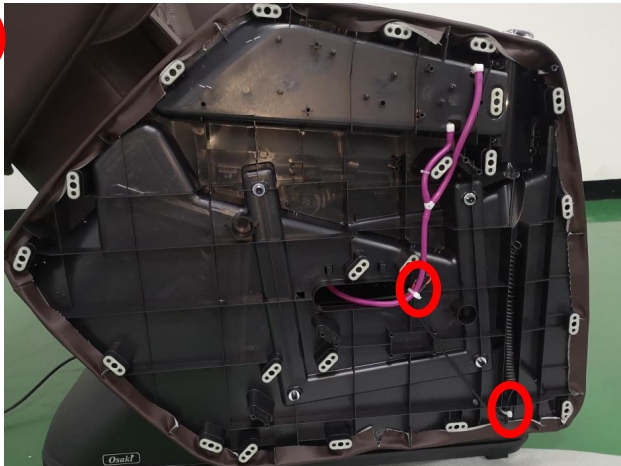

cut the cable tie and disconnected the terminal

2



remote control had been taken down

3



remove 4 screws

4



remove the box

5



remove the decoration

### 3.6、disassembly of shoulder



force the cover with the hands



disconnected the terminal and air hose, remove 4 screws



left shoulder



force the cover with the hands



disconnected the terminal and air hose, remove 4 screws



right shoulder



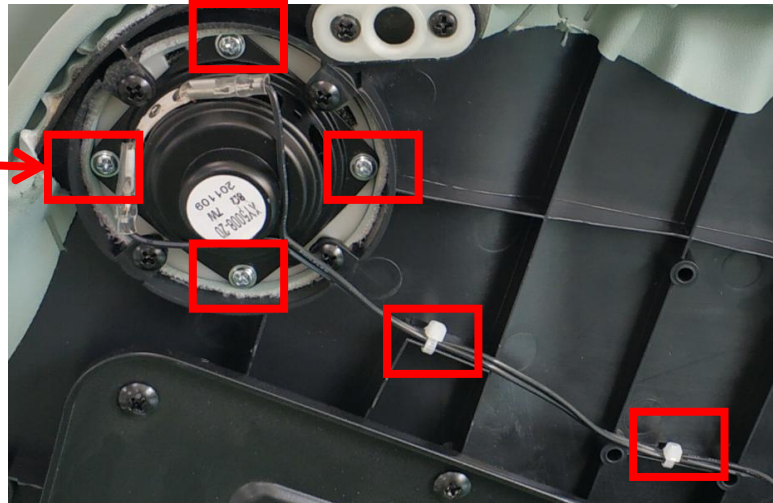
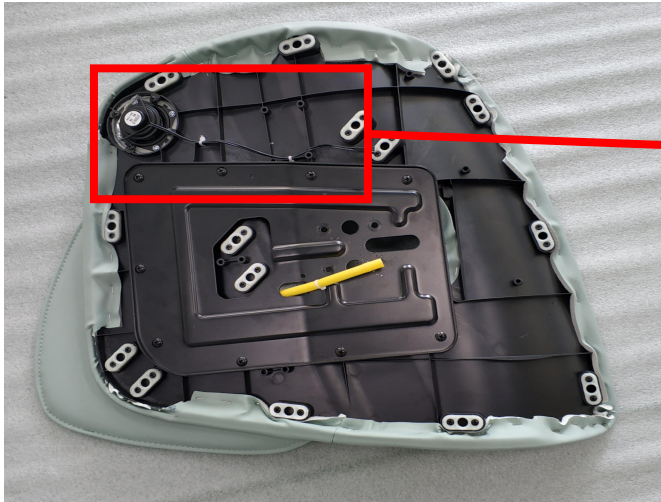

cut the cable tie, remove 4 screws, remove the horn

3.7、disassembly of the backrest cable (remove the shoulder first refer to 3.6、disassembly of shoulder )



unzip the zipper



remove 2 screws on the top

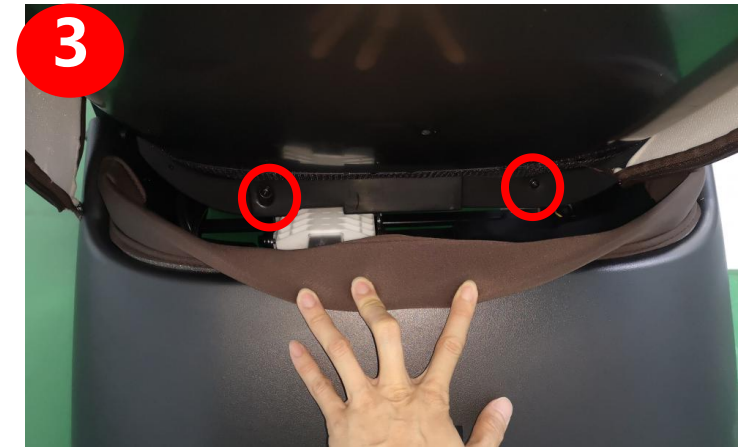

remove 2 screws on the bottom



remove the rear cover

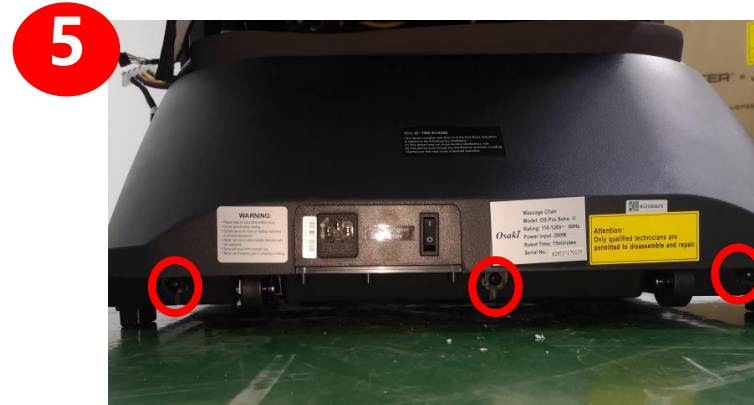

remove 3 screws



remove the cover

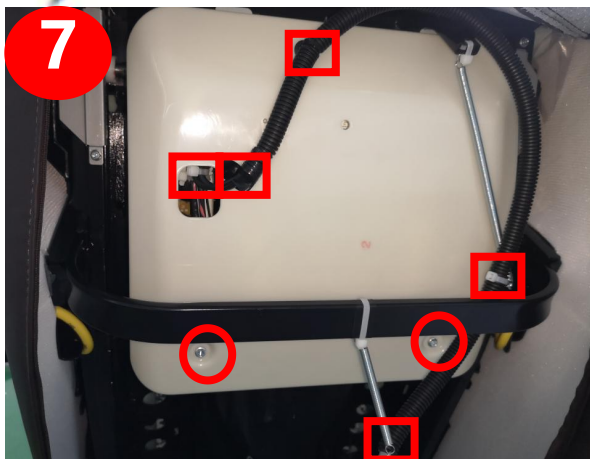

cut the cable tie and remove 2 screws

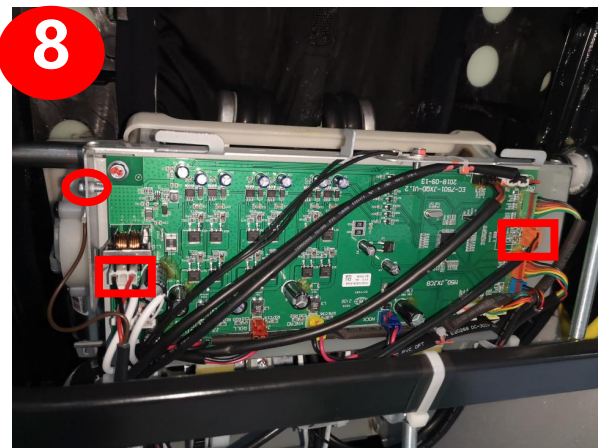

remove the screw  
disconnected the terminals



remove the cover

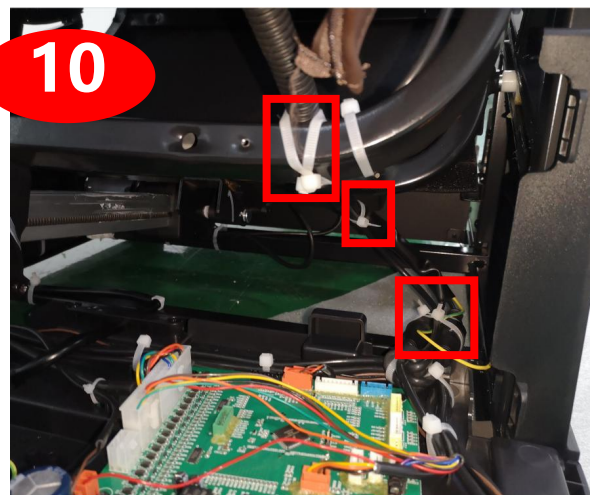

cut the cable tie

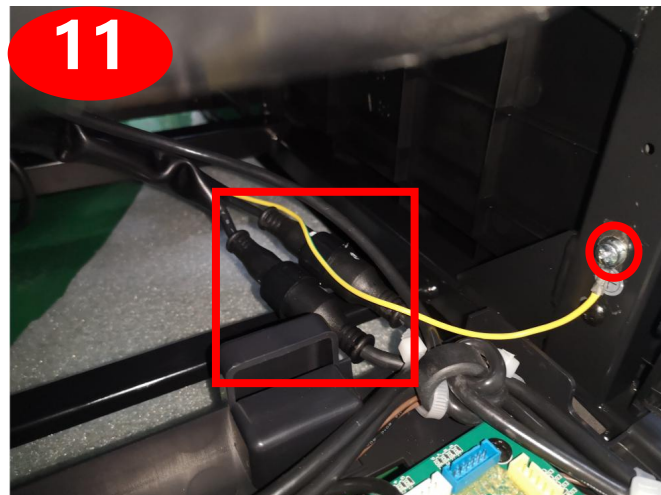

disconnected the terminals, remove the screw



remove backrest cable



3.8、disassembly of the mechanism (remove the shoulder first refer to 3.6、disassembly of shoulder )



unzip the zipper



remove 2 screws on the top

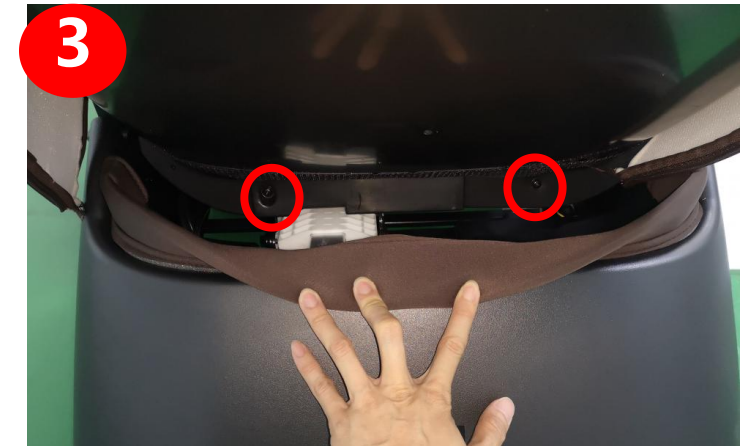

remove 2 screws on the bottom



remove the rear cover

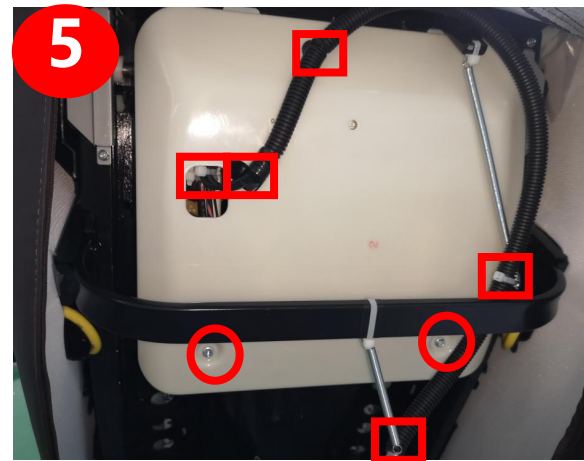

cut the cable tie and remove 2 screws

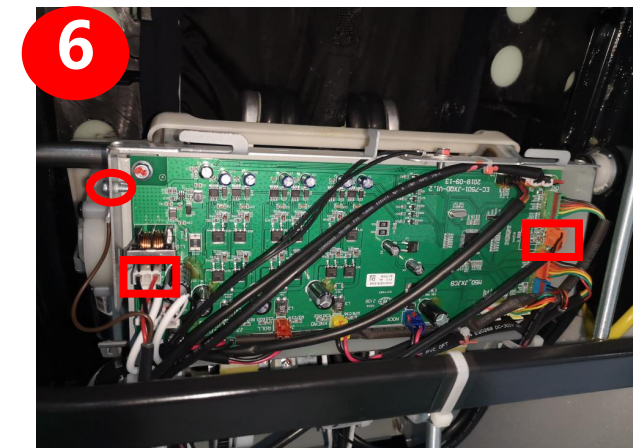

remove the screw  
disconnected the terminals



7

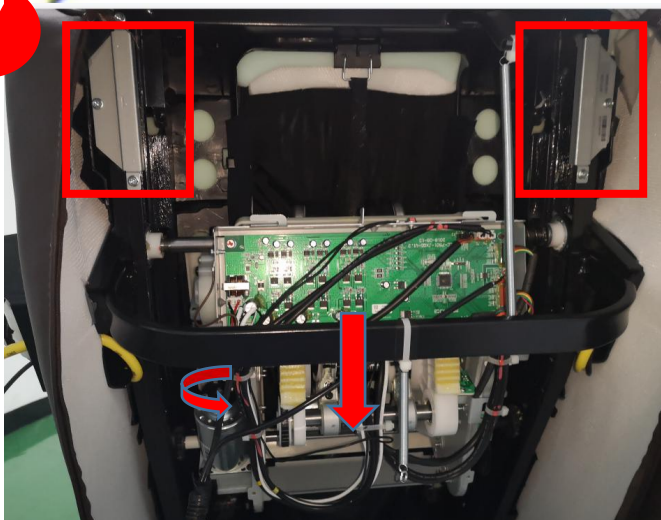

Rotate the encoder counter clockwise, mechanism go down

8



remove the limit baffle

9

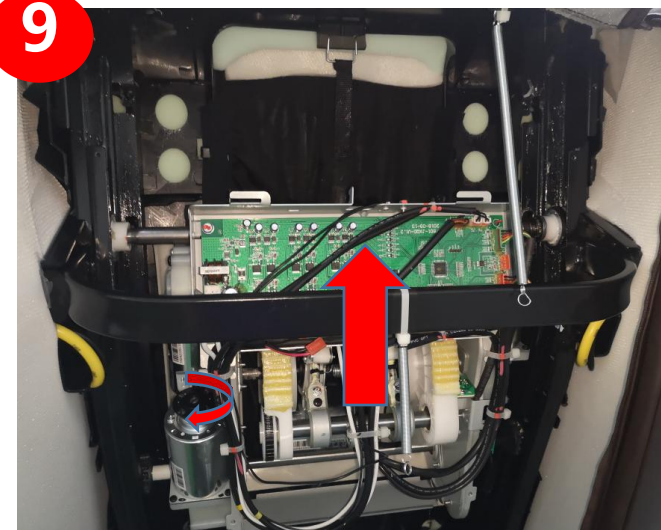

Rotate the encoder clockwise

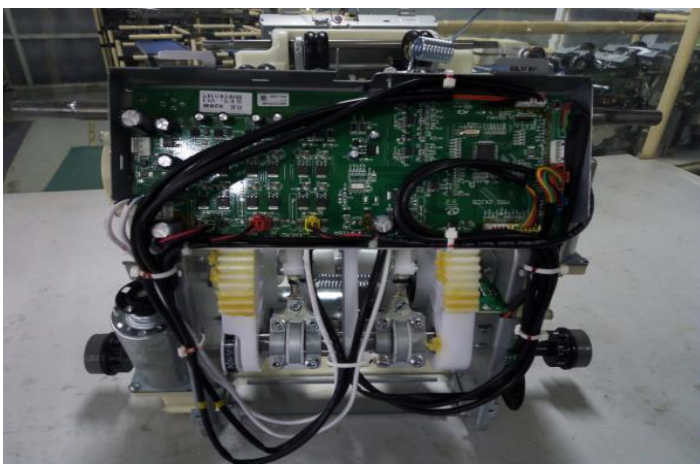

remove the mechanism



3.9、disassembly of the 3D PCB (remove the shoulder first refer to 3.6、disassembly of shoulder )



unzip the zipper



remove 2 screws on the top



remove 2 screws on the bottom



remove the rear cover

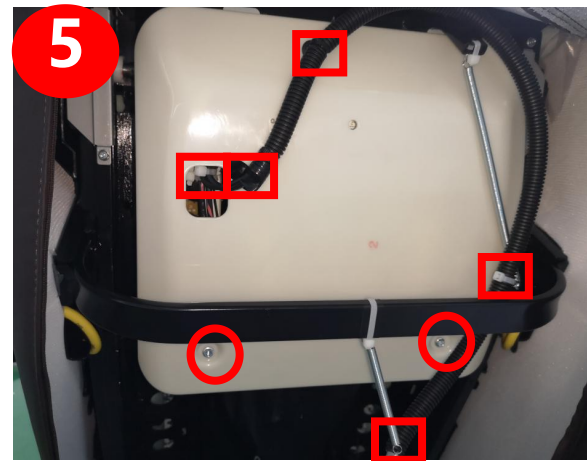

cut the cable tie and remove 2 screws

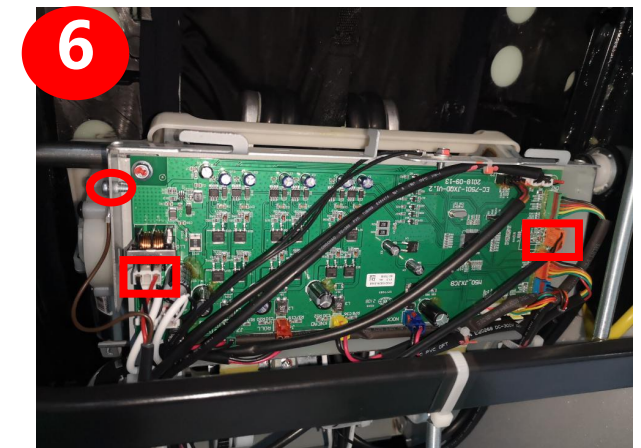

remove the screw  
disconnected the terminals

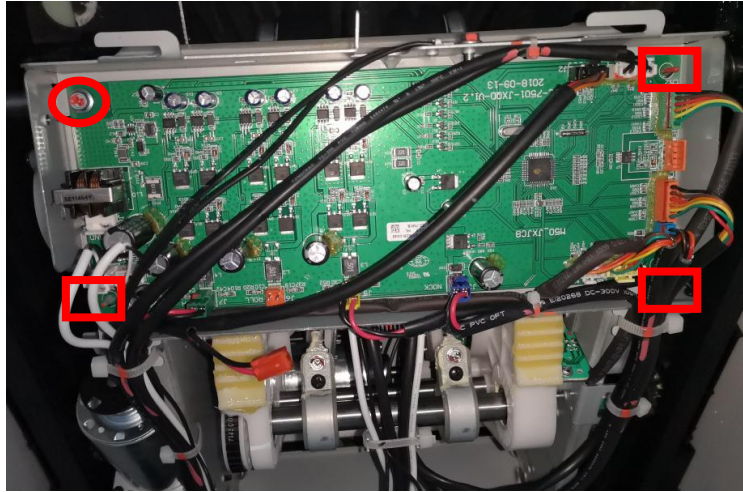

disconnected the terminals,  
remove 1 screw, then separate  
3D PCB from the plastic holder

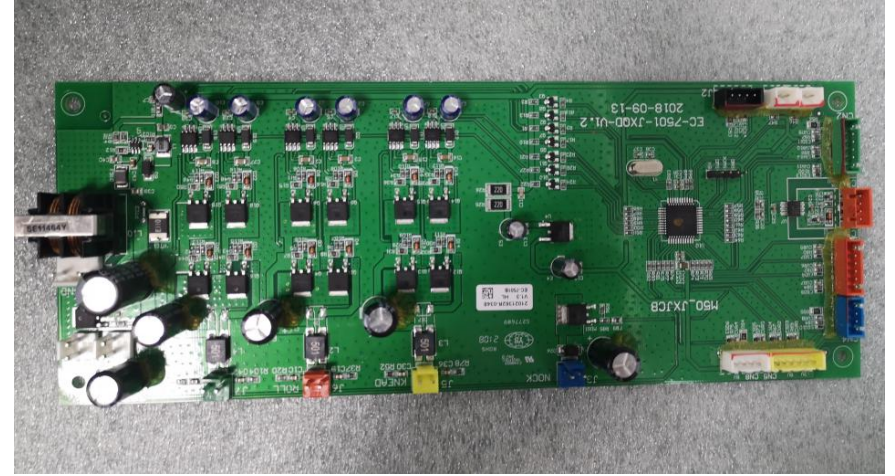

3D PCB had been taken down

### 3.10、disassembly of the inner main PCB box: main PCB

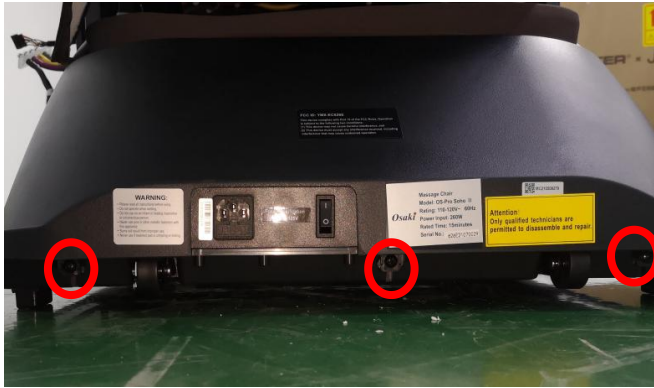

remove 3 screws



remove the cover

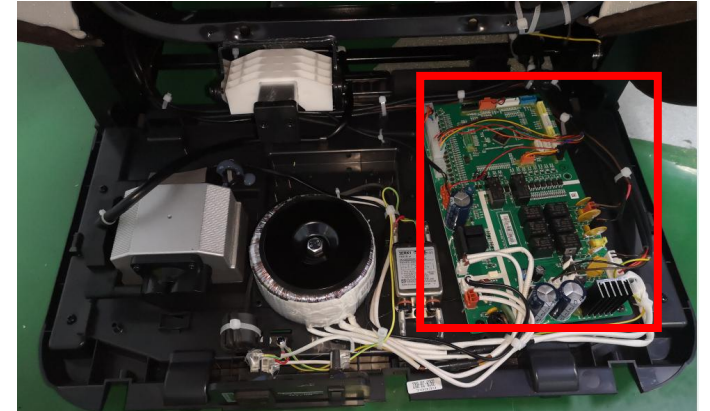

main PCB

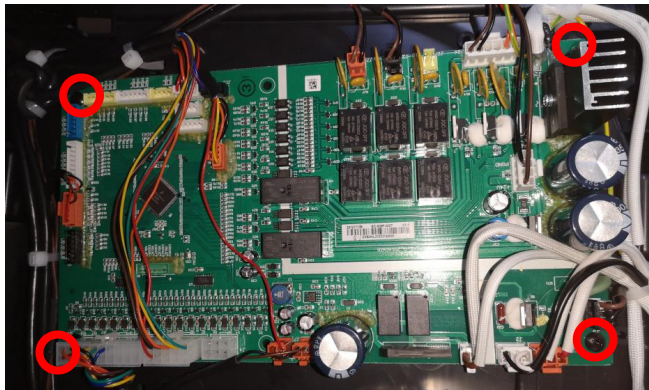

disconnected all terminals  
remove 4 screws

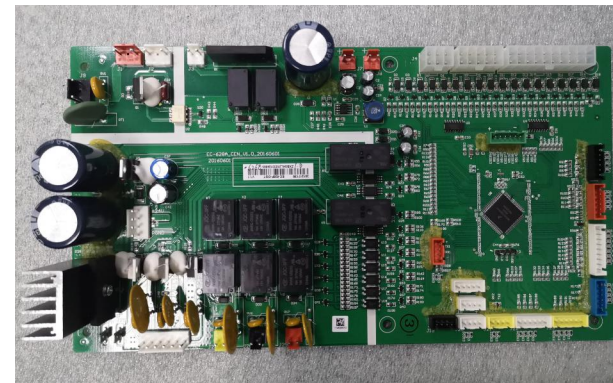

main PCB had been taken down



**3.11、disassembly of the inner main PCB box: Wave filter**

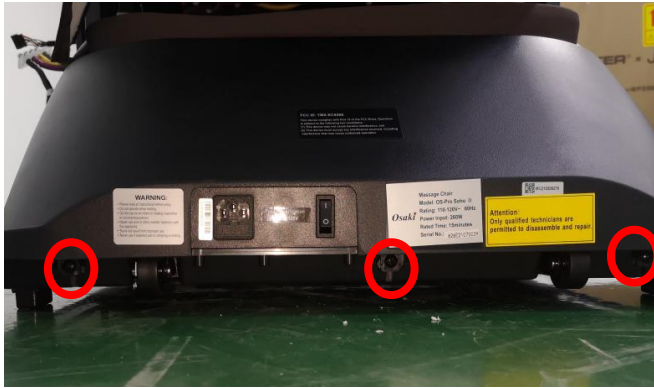

remove 3 screws



remove the cover

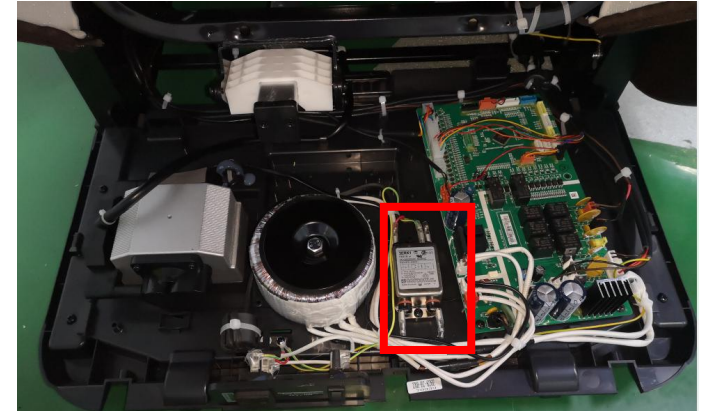

remove 2 screws and  
remove wave filter

**3.12、disassembly of the inner main PCB box: Air pump**

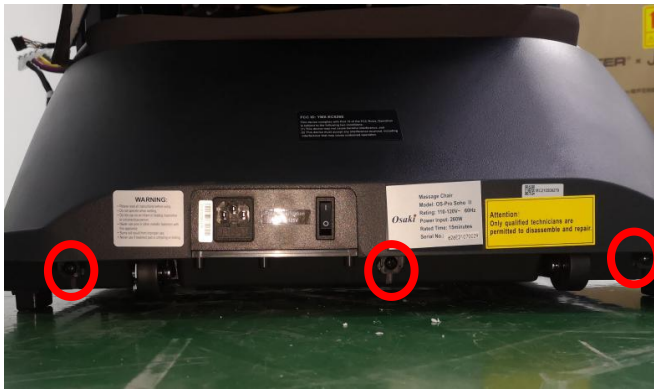

remove 3 screws



remove the cover

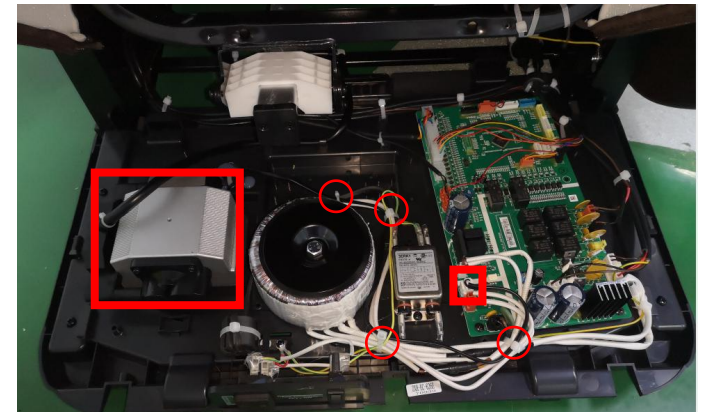

cut the cable tie and  
disconnected the terminal

### 3.13、 disassembly of the inner main PCB box: transformer

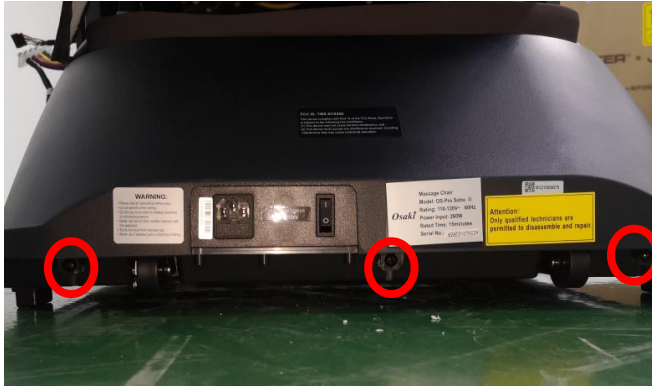

remove 3 screws



remove the cover

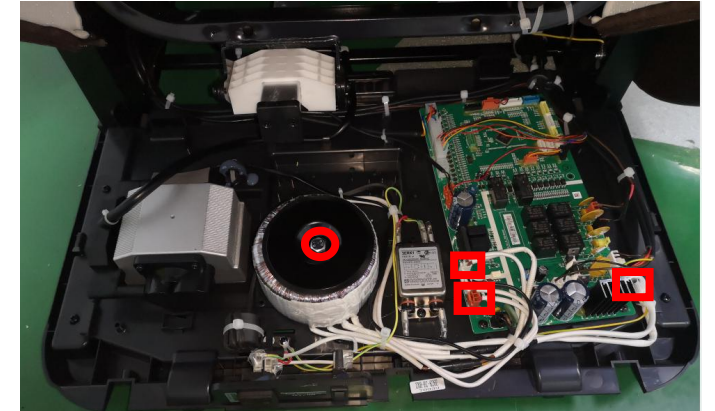

remove the screw and disconnected the terminals



3.14、disassembly of legrest



unzip the zipper



remove 2 Baffle

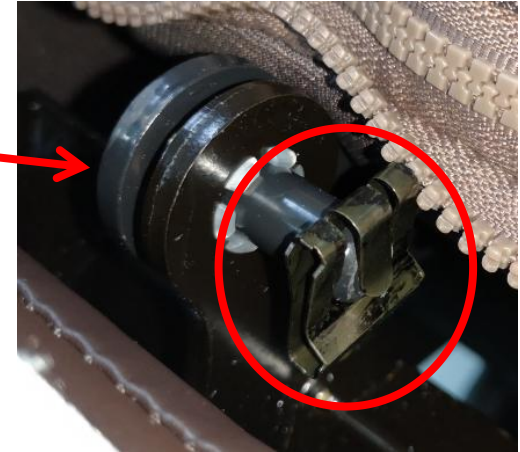

disconnected the terminal and air hose



page 35



legrest



### 3.15、disassembly of upper legrest

a.remove legrest first

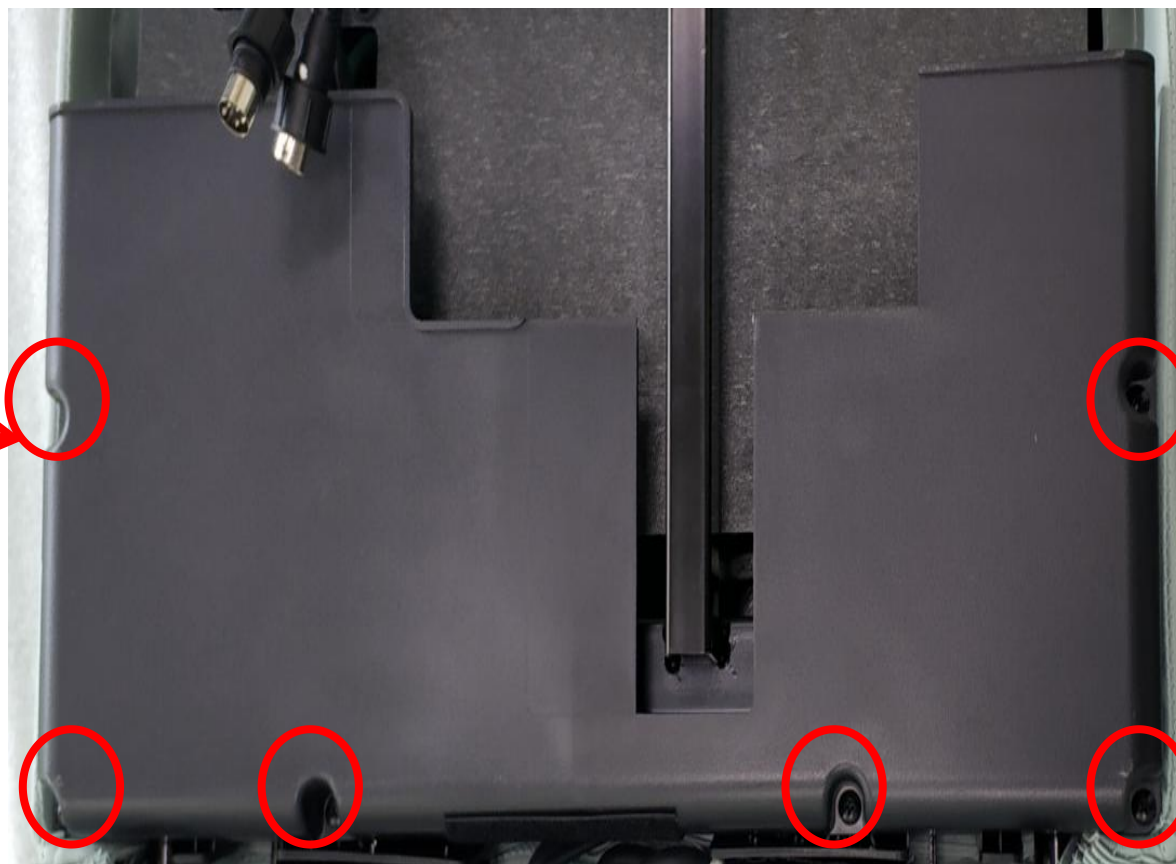
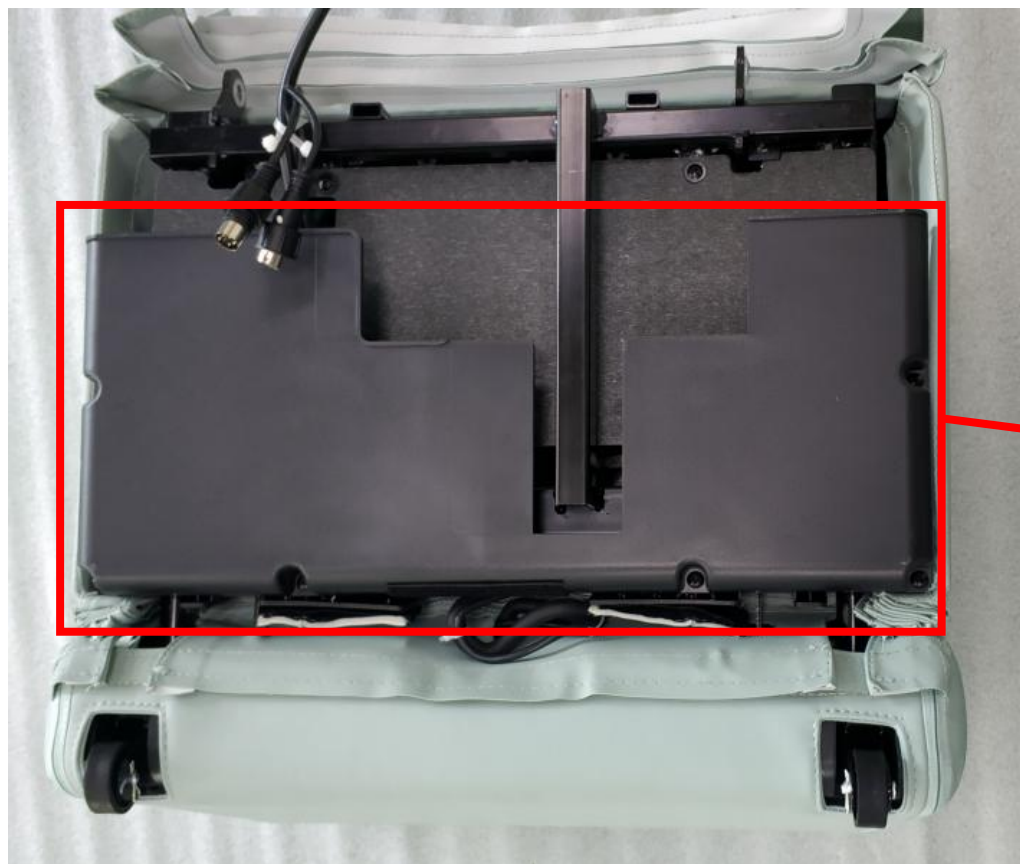

remove 6 screws

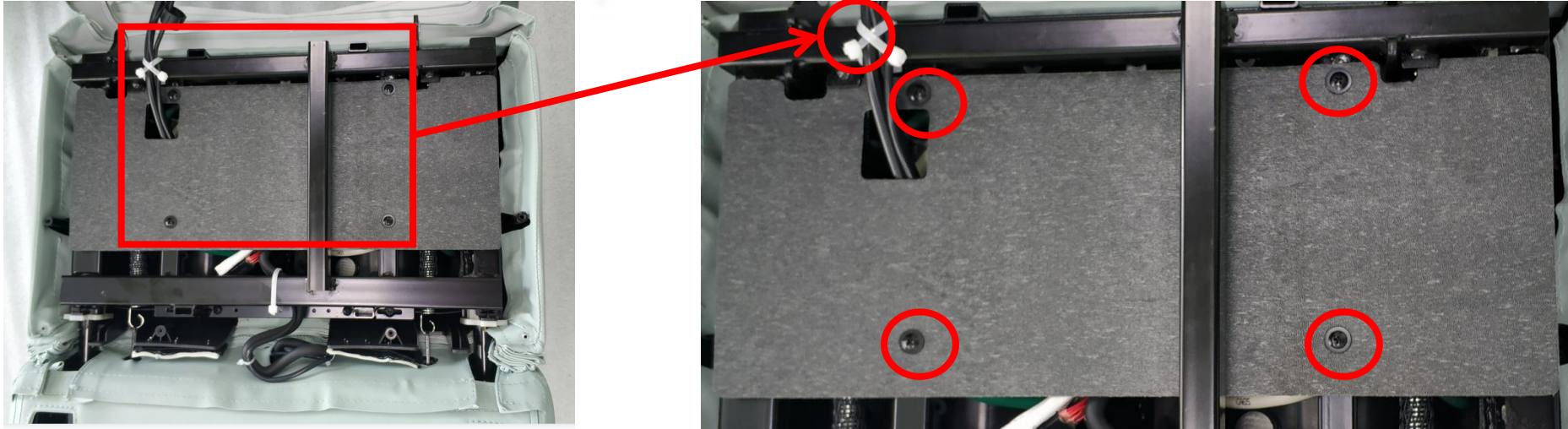

cut the cable tie and remove 4 screws, remove the PE board

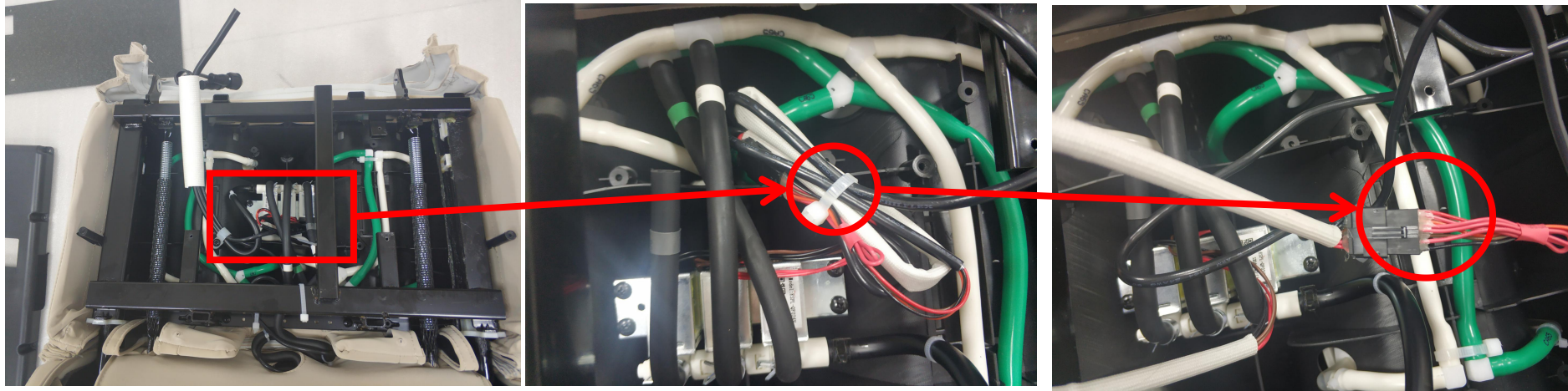

cut the cable tie, disconnected the terminals

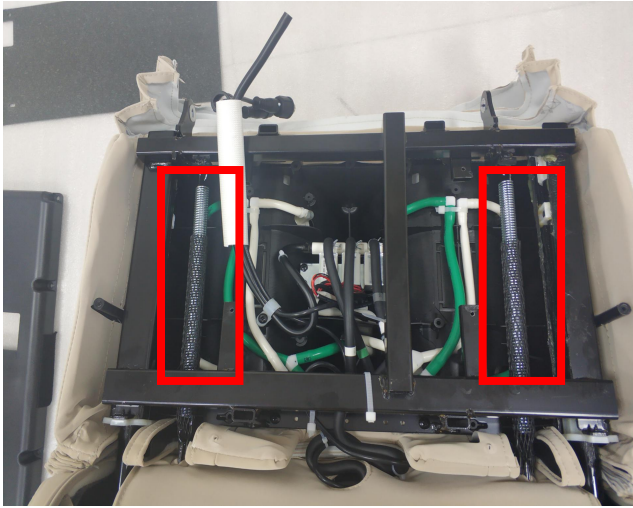

remove the spring

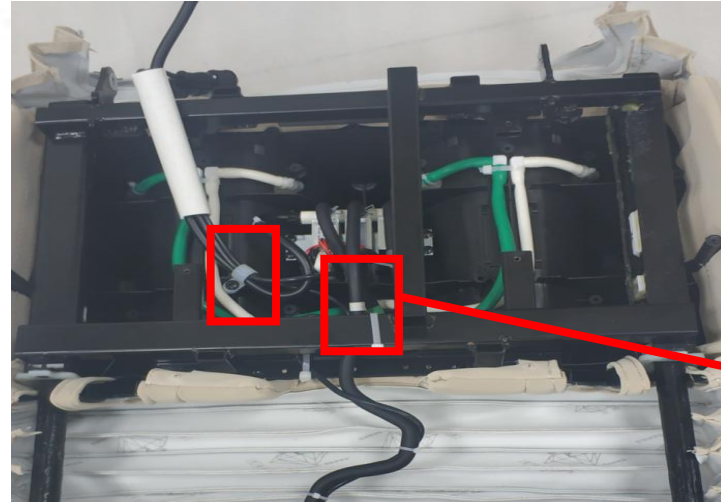

disconnected the air hose

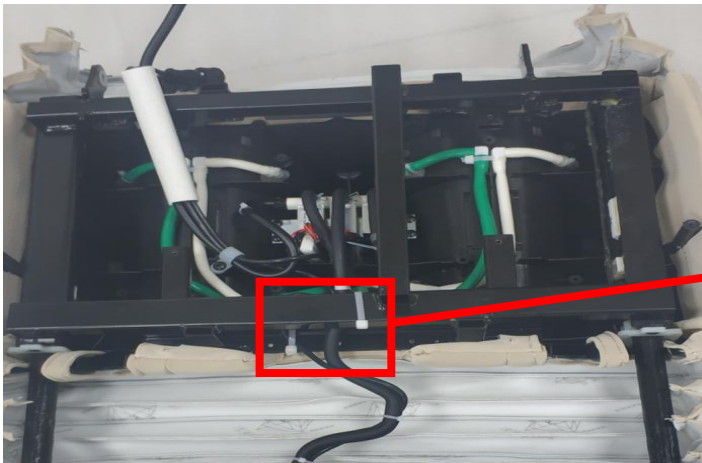
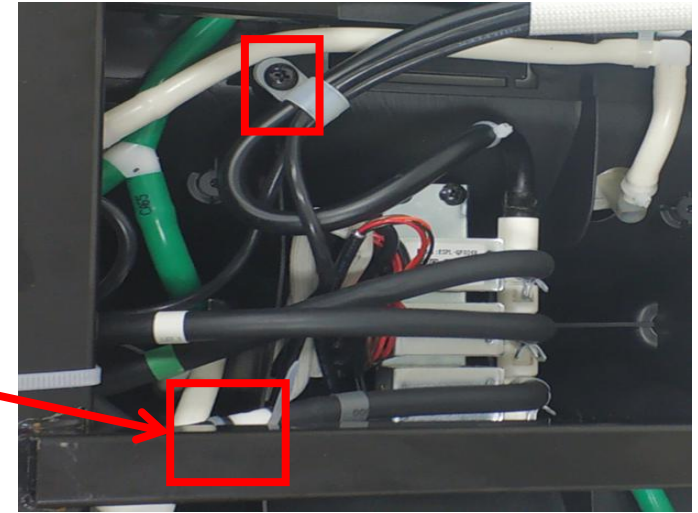

cut the cable tie

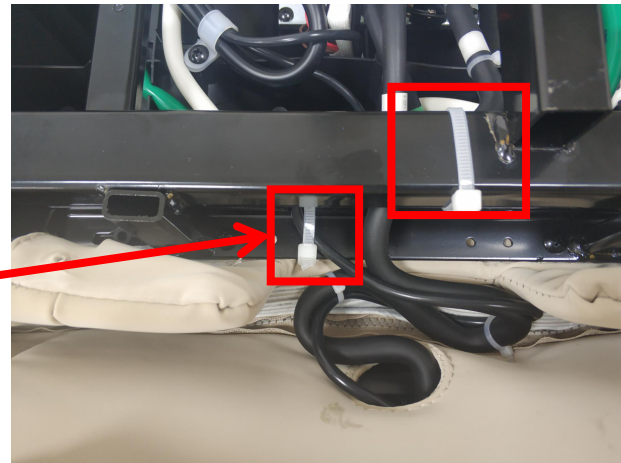

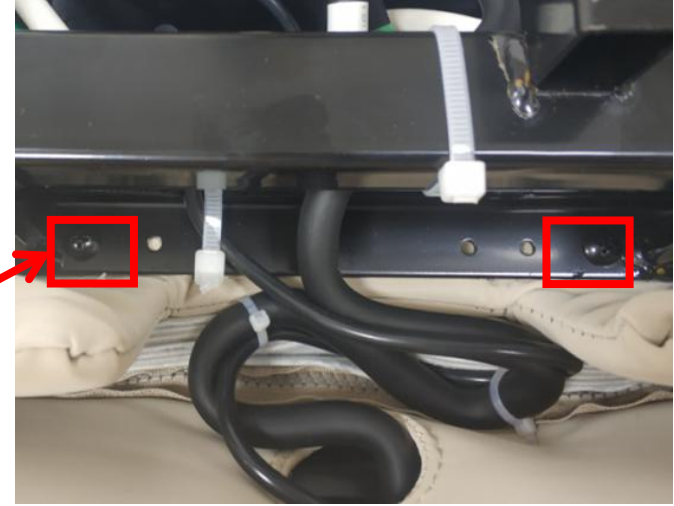
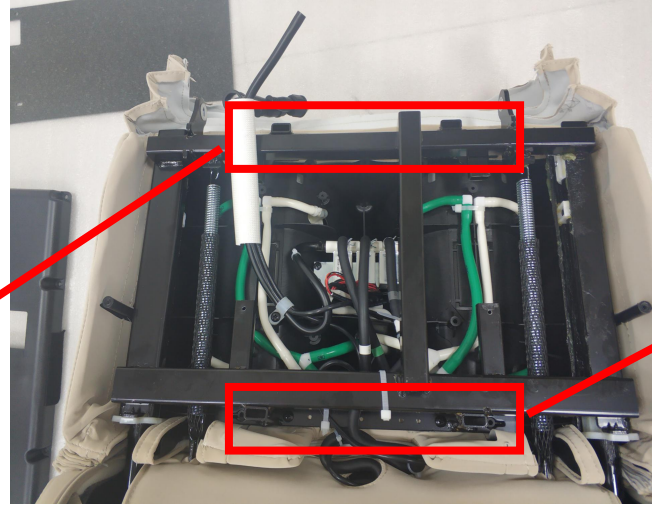
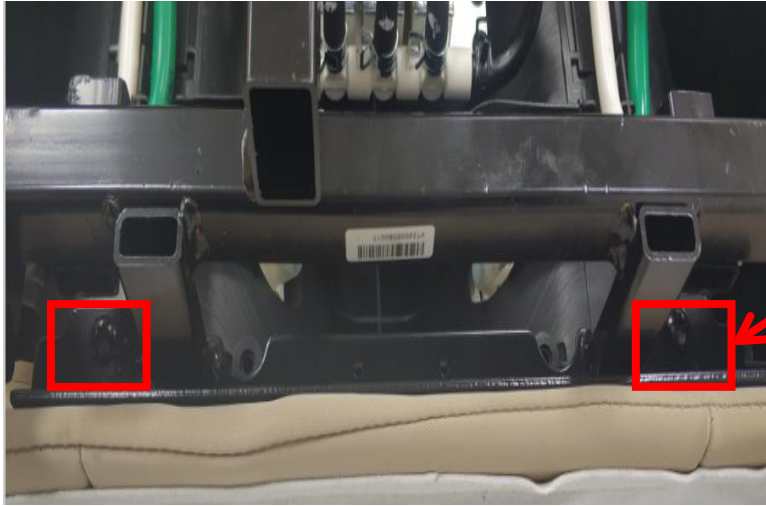

remove the screws fixing upper legrest

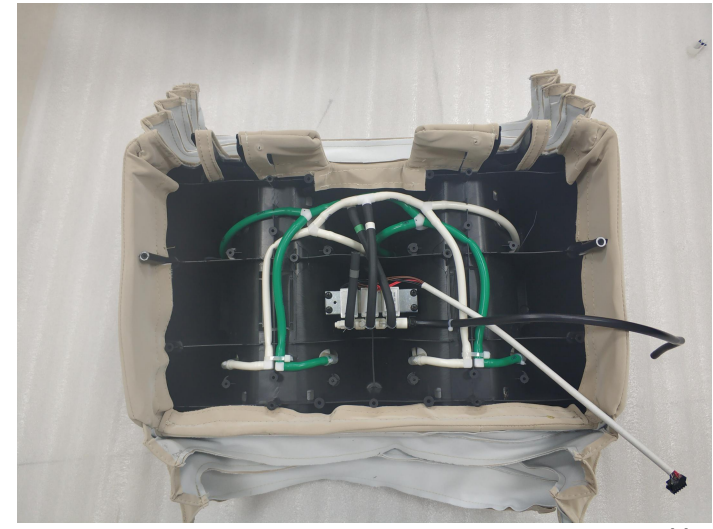
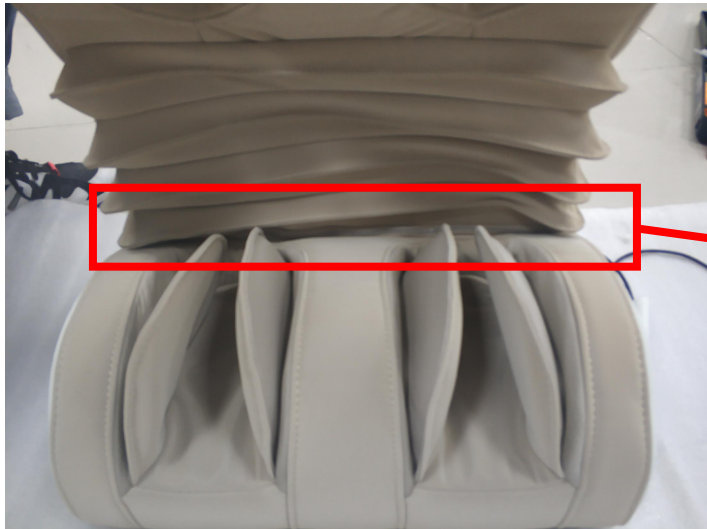

upper legrest



EASEPAL

厦门蒙发利电子有限公司客户服务部

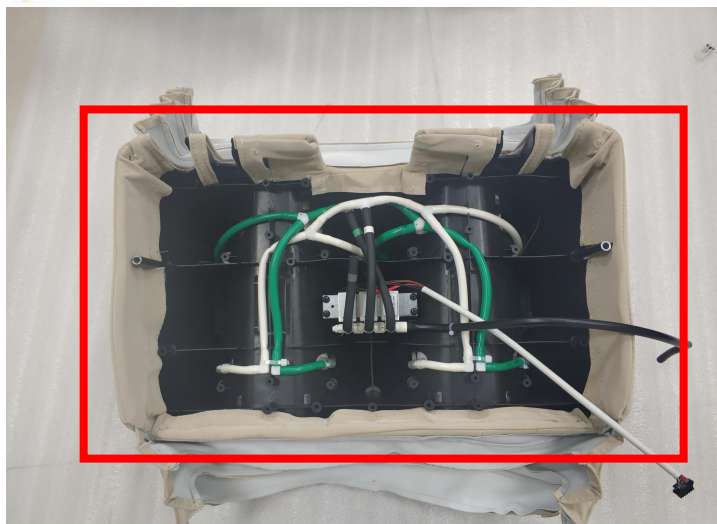

remove the leather

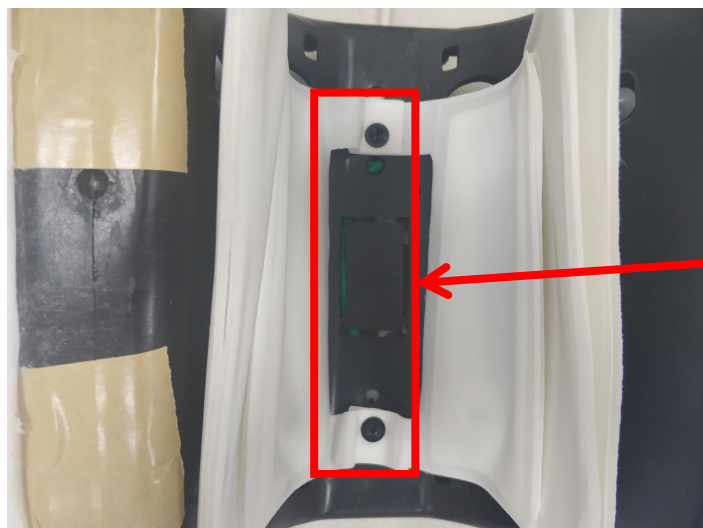

remove the screws fixing air bag  
page 40





EASEPAL

厦门蒙发利电子有限公司客户服务部

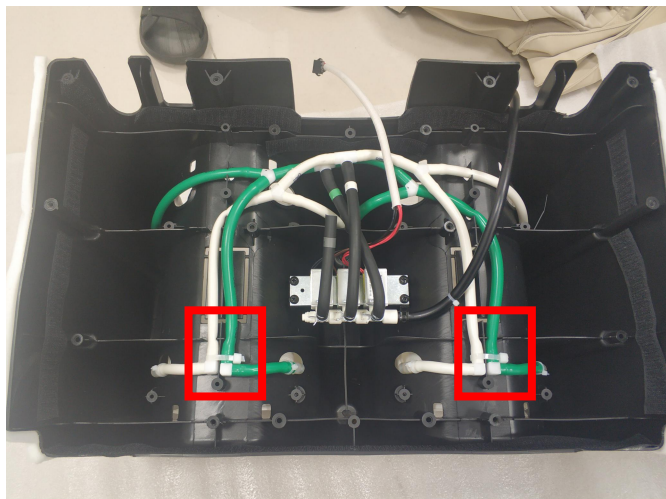

cut cable tie, disconnected the air hose

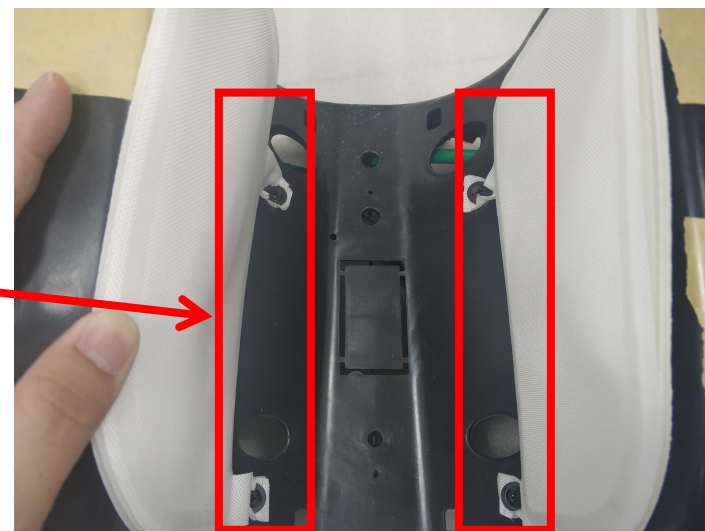
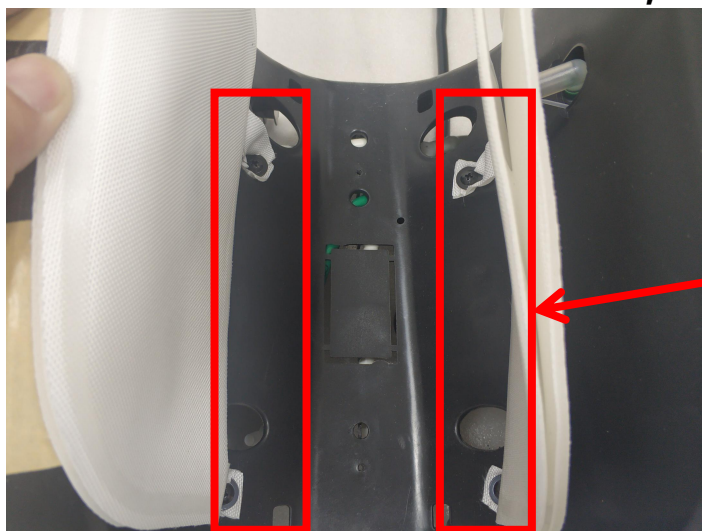

remove the screws fixing the air bag

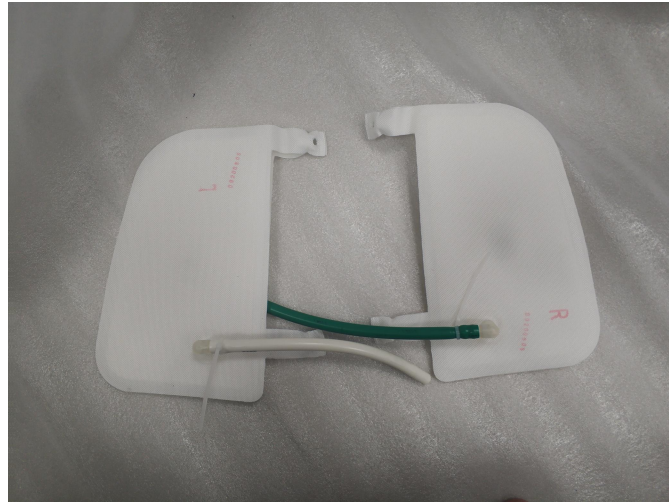
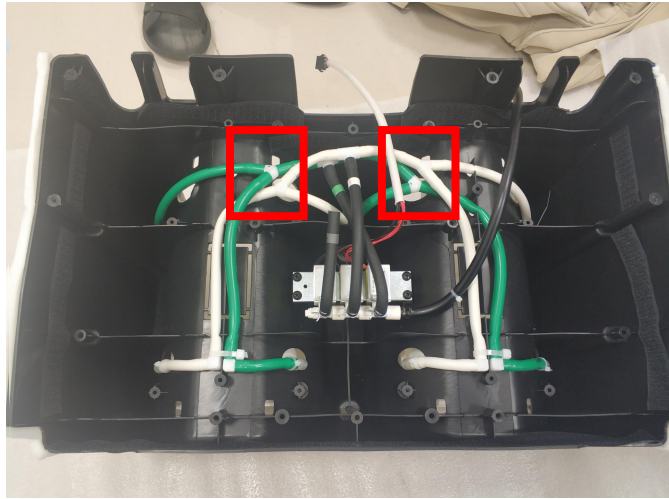

cut cable tie, disconnected the air hose

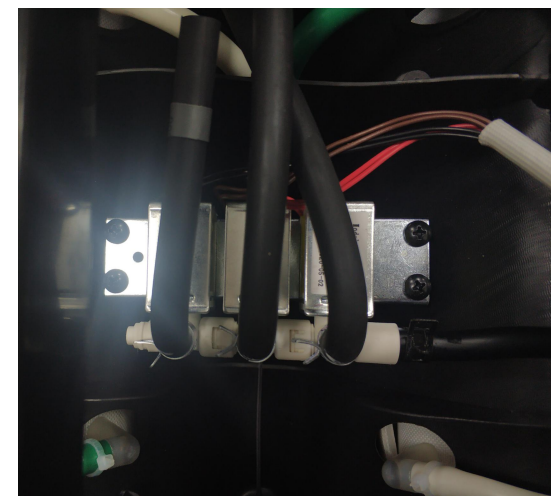
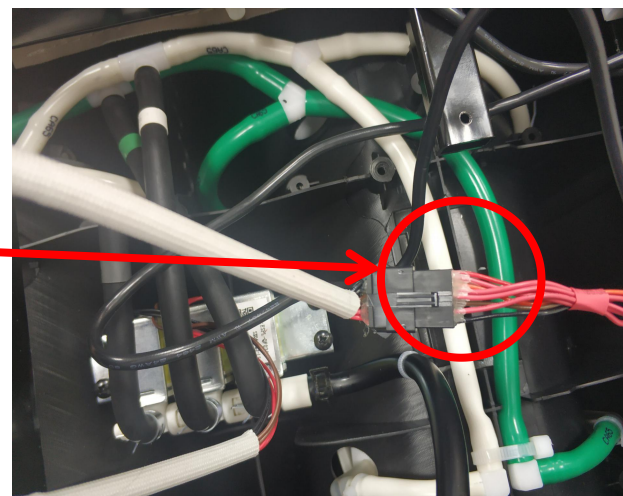
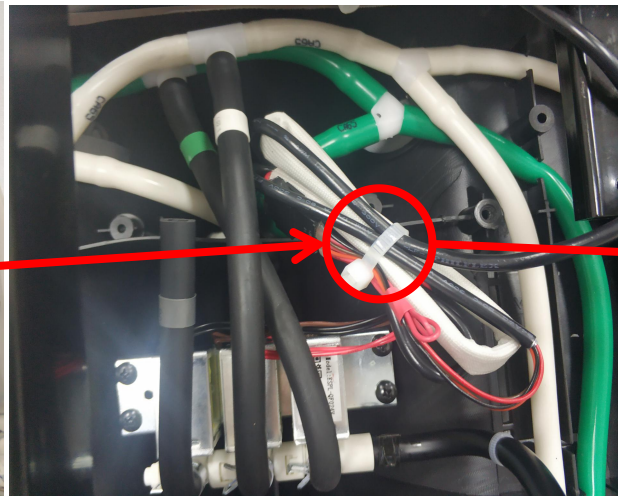
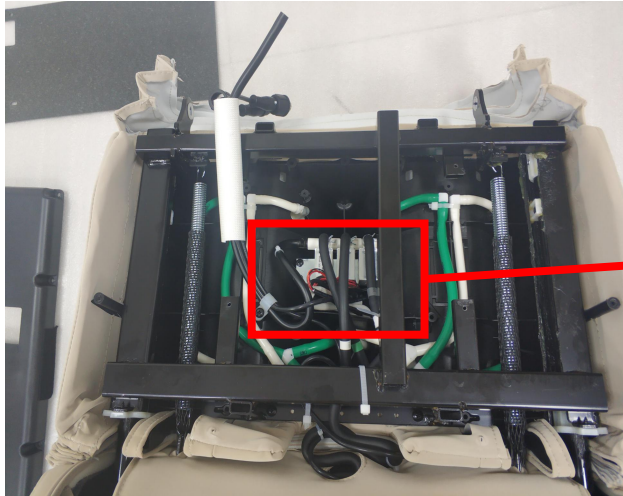

cut the cable tie, disconnected the terminals

remove 4 screws, disconnected the terminal and air hose, remove the air valve

第2页



EASEPAL

厦门蒙发利电子有限公司客户服务部

### 3.16、disassembly of lower legrest



open the leather

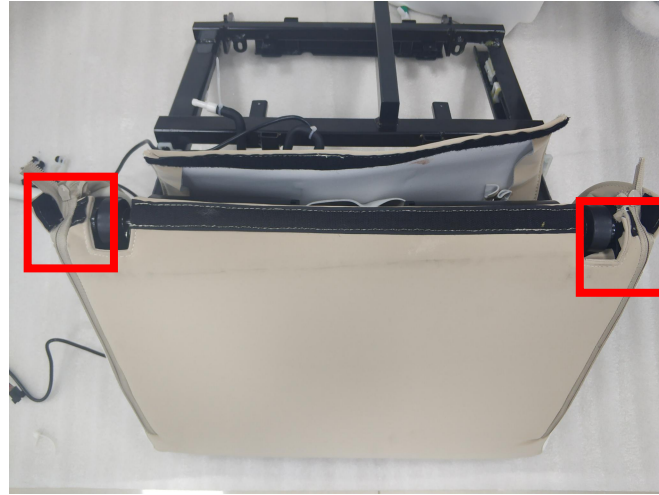

unzip the zipper

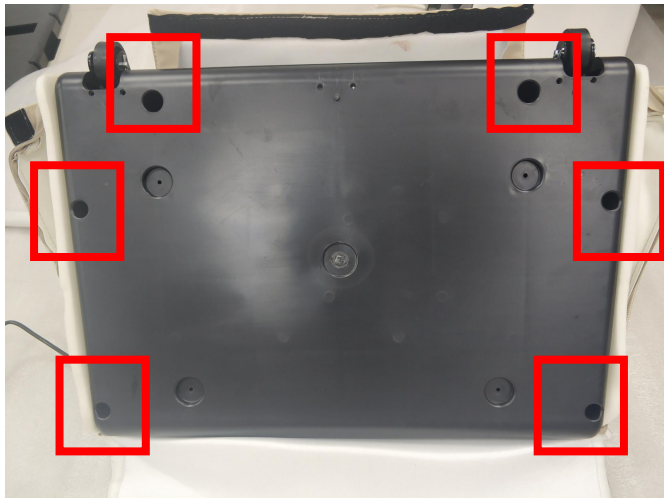

remove the screws

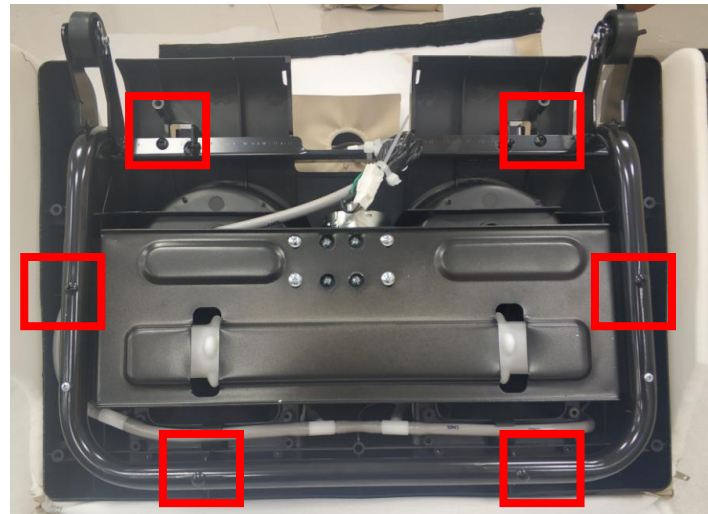

remove the screws



EASEPAL

厦门蒙发利电子有限公司客户服务部

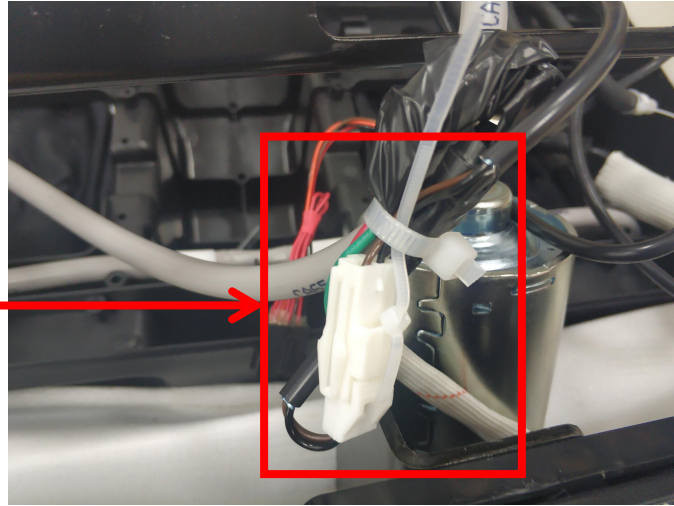
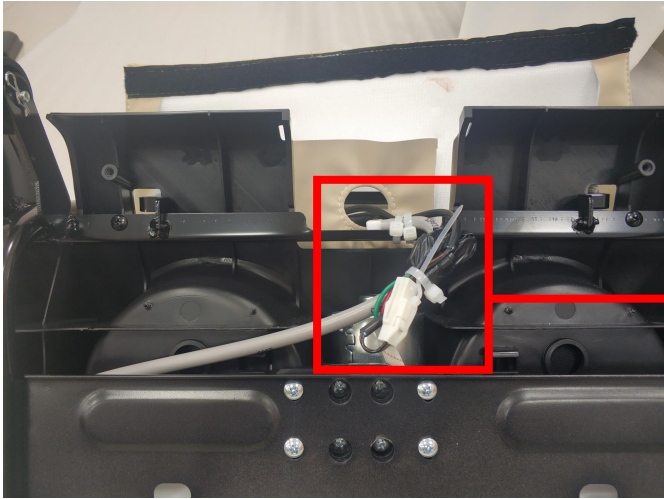

cut the cable tie, disconnected the terminal



remove lower legrest



remove the leather

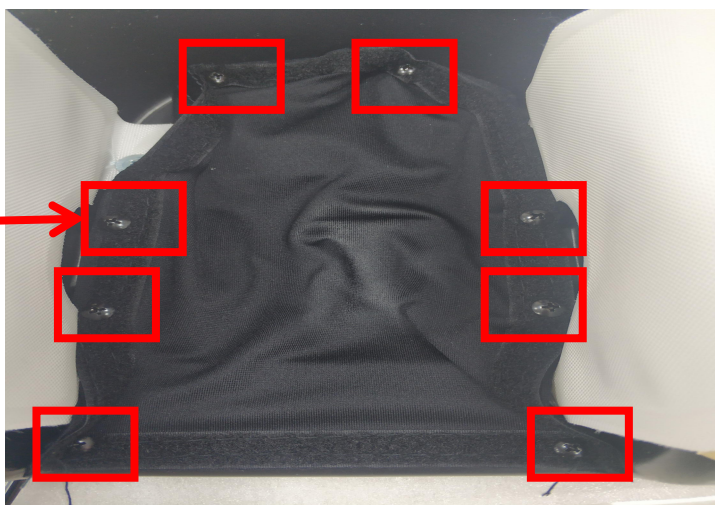
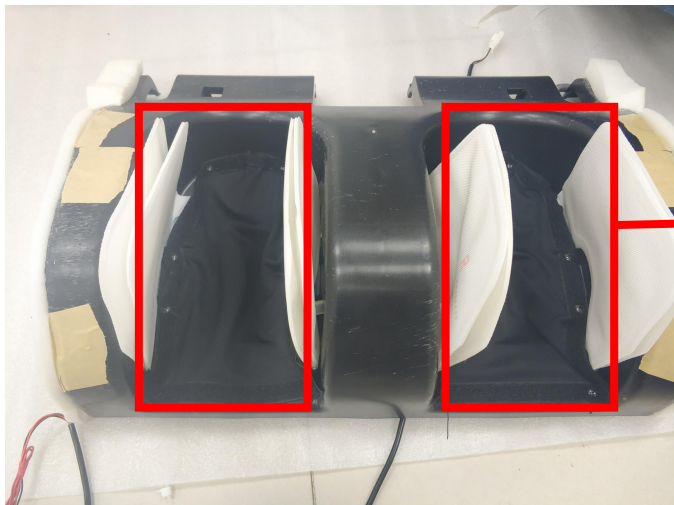

remove the screws

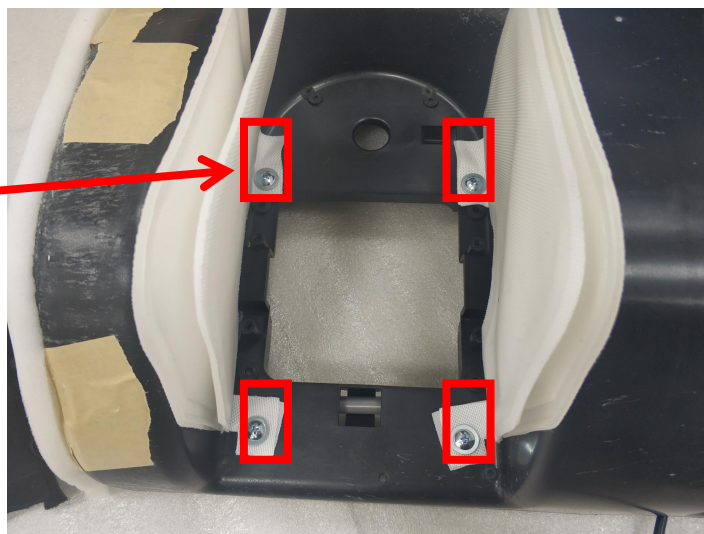
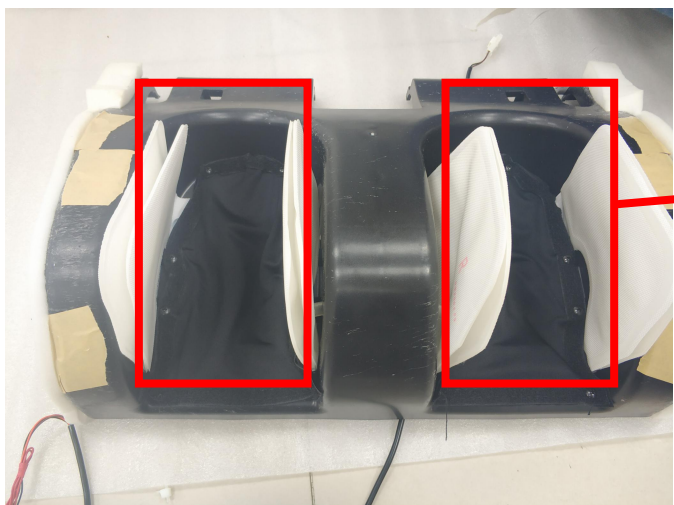

remove the screws

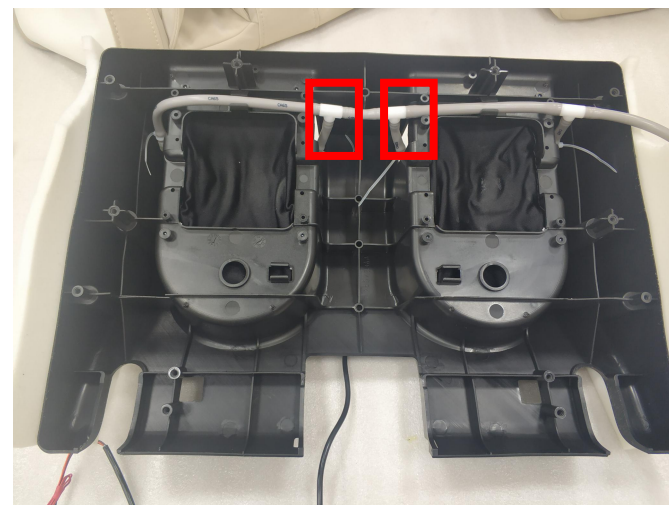

disconnected the air hose



EASEPAL

厦门蒙发利电子有限公司客户服务部

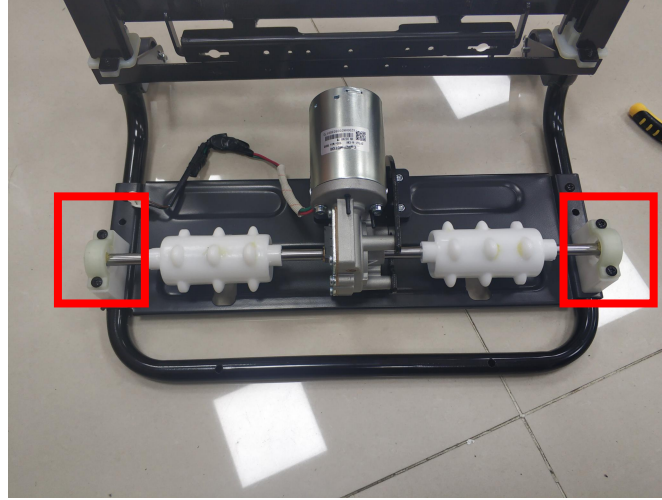
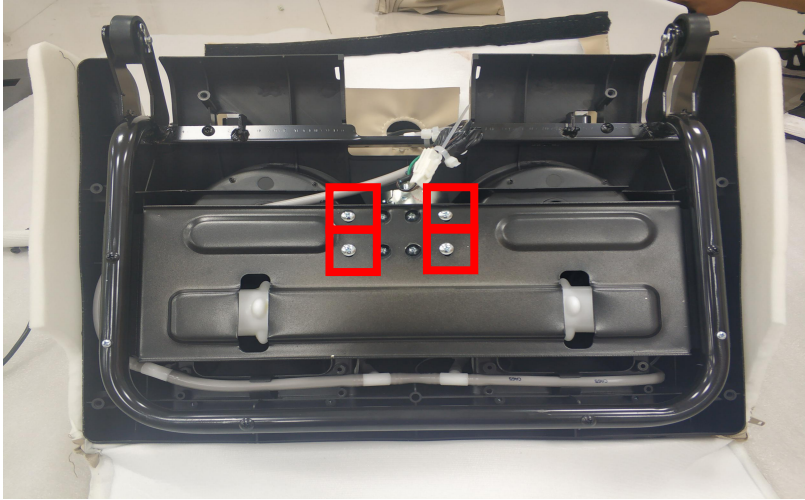

remove the screws and remove foot roller



3.17、disassembly of the backre actuator:



Rollover massage chair

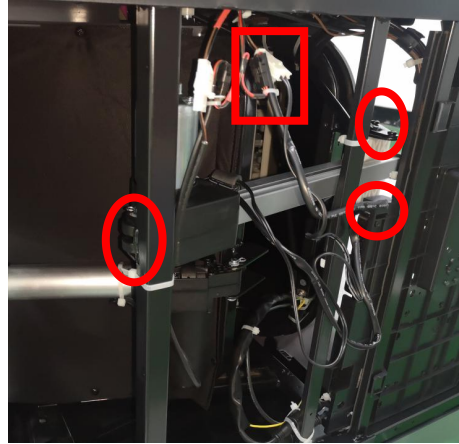

disconnected the terminals,  
remove the shaft and screws



remove backrest actuator

3.18、disassembly of the legrest actuator:



Rollover massage chair

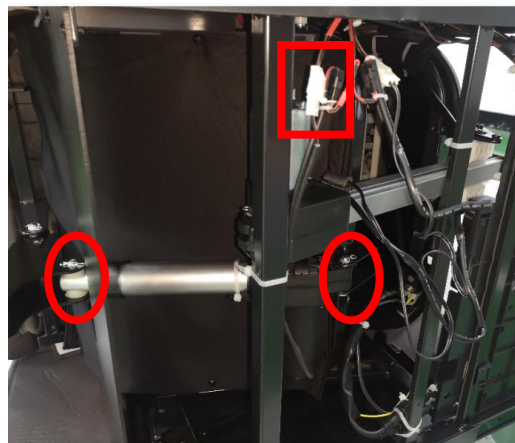

disconnected the terminals,  
remove the shaft



remove legrest actuator



## 五、Massage chair fault judgment

No.	phenomenon	problem description	steps of shooting the trouble	remark
02	remote control did not connected well	1.remote control wire is broken 2. tested signals from up & down limit sensor at the same time.	1. check the connector of remote control 2. replace the wire of remote control	enter auto-check model
03	backrest signal is abnormality	1.The connector of the backrest cable is not well connected 2.Backrest cable broken	1. check the connector of backrest wire 2. replace the backrest cable	enter auto-check model
40	The position sensor of the rolling motor is abnormal, no change of the position code disk is detected after 8s.	1. Position sensor is broken 2. The connection between the main PCB and the 3D PCB is abnormal 3. rolling motor is broken or locked 4. Drive circuit components are damaged	1. change the sensor 2. check the wire 3. check or change the motor 4. change main PCB	enter auto-check model
41	<b>The position coding of rolling motor is abnormal, the code disk is in an incorrect position</b>	1. position sensor broken 2. Incorrect initial position of code disk 3. mechanism overshoot	1. replace the sensor 2. the mechanism to the initial height position, and then turn the code disk to the correct initial position.	enter auto-check model





## 五、Massage chair fault judgment

42	The rotation speed sensor of the core massage (rolling) motor is abnormal, that is, no change of the rotation speed code disk is detected more than 6S.	1.position sensor is broken 2.The connection between the main PCB and the 3D PCB is abnormal 3.motor is broken or locked 4.Drive circuit components are damaged	1.change the sensor 2.check the wire 3.check or change the motor 4.change main PCB	enter auto-check model
44	The position sensor of the core kneading motor is abnormal, that is, no change of the position code plate is detected after 10s.	1.position sensor is broken 2.The connection between the main PCB and the 3D PCB is abnormal 3.motor is broken or locked 4.Drive circuit components are damaged	1.change the sensor 2.check the wire 3.check or change the motor 4.change main PCB	enter auto-check model
46	The rotation speed sensor of the core kneading motor is abnormal, that is, no change of the rotation speed code disk is detected after 6S.	1.position sensor is broken 2.The connection between the main PCB and the 3D PCB is abnormal 3.motor is broken or locked 4.Drive circuit components are damaged	1.change the sensor 2.check the wire 3.check or change the motor 4.change main PCB	enter auto-check model
48	The position sensor of the core expansion motor is abnormal, i.e. no change of the position code disk is detected after 10s.	1.position sensor is broken 2.The connection between the main PCB and the 3D PCB is abnormal 3.motor is broken or locked 4.Drive circuit components are damaged	1.change the sensor 2.check the wire 3.check or change the motor 4.change main PCB	enter auto-check model



## 五、Massage chair fault judgment

49	The position coding of the core expansion motor is abnormal, that is, the code disk is in an incorrect position.	<ol style="list-style-type: none"> <li>1. position sensor is broken</li> <li>2. Incorrect initial position of code disk</li> <li>2. mechanism overshoot</li> </ol>	<ol style="list-style-type: none"> <li>1. change the sensor</li> <li>2. Move the mechanism to the initial retraction position</li> </ol>	enter auto-check model
50	Abnormal rotation speed (count) sensor of core expansion motor	<ol style="list-style-type: none"> <li>1. position sensor is broken</li> <li>2. The connection between the main PCB and the 3D PCB is abnormal</li> <li>3. motor is broken or locked</li> <li>4. Drive circuit components are damaged</li> </ol>	<ol style="list-style-type: none"> <li>1. change the sensor</li> <li>2. check the wire</li> <li>3. check or change the motor</li> <li>4. change main PCB</li> </ol>	enter auto-check model
52	Abnormal rotation speed (count) sensor of core tapping motor	<ol style="list-style-type: none"> <li>1. position sensor is broken</li> <li>2. The connection between the main PCB and the 3D PCB is abnormal</li> <li>3. motor is broken or locked</li> <li>4. Drive circuit components are damaged</li> </ol>	<ol style="list-style-type: none"> <li>1. change the sensor</li> <li>2. check the wire</li> <li>3. check or change the motor</li> <li>4. change main PCB</li> </ol>	enter auto-check model
59	backrest Count sensor abnormal	<ol style="list-style-type: none"> <li>1. count sensor broken</li> <li>2. the wire is broken</li> <li>3. motor is broken or locked</li> <li>4. Drive circuit components are damaged</li> </ol>	<ol style="list-style-type: none"> <li>1. change the sensor</li> <li>2. check the wire</li> <li>3. check or change the motor</li> <li>4. change main PCB</li> </ol>	enter auto-check model



### 五、Massage chair fault judgment

63	leg rest Count sensor abnormal	1. count sensor broken 2. the wire is broken 3. motor is broken or locked 4. Drive circuit components are damaged	1. change the sensor 2. check the wire 3. check or change the motor 4. change main PCB	enter auto-check model
----	--------------------------------	--	---	------------------------