

*Osaki*  
P L A T I N U M

Instruction Manual

Somnus 4D DuoFlex









# *Osaki*

P L A T I N U M

Thank you for purchasing this product.  
Please read this manual carefully and thoroughly before using.  
Please keep this Instruction Manual properly on hand for future reference.  
This product is designed for home use.



# Contents

## Before Use

---

- Important Safety Instructions ..... EN 4
- Grounding Instructions ..... EN 9
- About Chair..... EN 10
- Side Panel Control Instructions ..... EN 14
- Things To Do And Know Before Use ..... EN 16

## How to Use

---

- Adjust The Headrest .....EN 20
- Activate The Massage Chair ..... EN 20
- Operational Instructions ..... EN 23
- After Massage.....EN 56

## Care & Maintenance

---

- Storage Instructions ..... EN 57
- Maintenance Instructions..... EN 57

## FAQ/Important Notes



---

- Frequently Asked Questions(FAQ) ..... EN 59
- Troubleshooting ..... EN 60
- Product Specifications ..... EN 62
- FCC Radiation Exposure Statement ..... EN 63
- Industry Canada Notice ..... EN 64



# Important Safety Instructions Must be followed



These safety instructions must be strictly followed in use to avoid personal injuries and property damage :

■ All the safety instructions are described in compliance with degrees of the injuries or damage as a result of wrong use.

 <b>Warning</b>	Actions leading to serious injury or death
 <b>Caution</b>	Actions leading to minor injury or property damage

■ Pay attention to the symbols before safety instructions (an example is given below).

 Actions that are absolutely forbidden	 Actions that must be done
---	---

 <b>Warning</b>	
 <b>Must be followed</b>	<ul style="list-style-type: none"> <li>● <b>IMPORTANT SAFETY INSTRUCTIONS</b> When using this product, basic precautions should always be followed, including the following: Read all instructions before using (this product).</li> <li>● <b>DANGER-To reduce the risk of electric shock:</b> <ul style="list-style-type: none"> <li>• Always unplug this product from the electrical outlet after using and before cleaning.</li> <li>• Never use unauthorized parts or hardware for this chair. No modifications are allowed.</li> <li>• Carefully examine the covering before each use. Carefully examine the upholstery from top to bottom. If there are any signs of cracking, blistering, rethreading, or tearing, stop using the product, and contact the manufacturer for a replacement or further instructions. Please unplug the chair from the power outlet.</li> <li>• This product must be kept in a climate-controlled area. 60-85 degrees Fahrenheit with very low moisture at ALL times.</li> </ul> </li> <li>● <b>WARNING-To reduce the risks of burn, fire, electric shock, or injury to persons:</b> <ul style="list-style-type: none"> <li>• An appliance should never be left unattended when plugged in. Unplug from outlet when not in use and before any authorized installs or alterations are being made.</li> <li>• Close supervision is required if you have any pets and children in the area when chair is being used.</li> <li>• Use this product only for its intended use as described in this manual. Do not use attachments not recommended by the manufacturer.</li> <li>• Never operate this product if it has damaged cord or plug, if it is not working properly, if it has been dropped, damaged or dropped into water. Contact the manufacturer for examination and repair.</li> <li>• Never pull on any cables or wires on this product.</li> <li>• Keep the cord away from heat source like a vent or humid area like a bathroom.</li> <li>• If any of the air hoses are plugged, stop using the chair and contact the manufacturer then unplug power from the outlet.</li> <li>• Never allow any object to fall into the chair or cracks of the chair.</li> <li>• This product is for indoor use only in a dry climate-controlled area.</li> <li>• Do not operate where aerosol (spray) products are being used or where oxygen is being administered.</li> <li>• To disconnect, turn controls off then remove plug from outlet.</li> <li>• Keep children away from this product as working parts can seriously injure a child or pet.</li> <li>• Connect this appliance to a properly grounded outlet only. See Grounding Instructions.</li> <li>• Carefully monitor the heating areas of the chair. If there is any abnormality or discomfort, turn off the chair, unplug the power from the outlet, and contact the manufacturer.</li> <li>• Do not operate this product using a blanket or pillow. Excessive heating can occur and cause fire, electric shock, or injury to persons.</li> <li>• Any elderly, disabled person, children (under 18) or person with a medical must consult with a doctor if this product can be used.</li> </ul> </li> </ul> <p style="text-align: center; margin-top: 10px;"><b>SAVE THESE INSTRUCTIONS</b></p> <ul style="list-style-type: none"> <li>● <b>Individuals who have an implanted medical device, medical condition, or are undergoing any medical treatment must get approval from their medical doctor to using this device.</b></li> </ul>

## ⚠ Warning

- |  |  |
|--|--|
| <ul style="list-style-type: none"> <li>(1) Any person with pacemaker cannot use this product. The chair may cause an electronic malfunction to the medical device;</li> <li>(2) Patients with malignant tumors;</li> <li>(3) Patients with heart disease;</li> <li>(4) Persons unable to feel or insensitive to heat on their skin such as diabetic patient;</li> <li>(5) Pregnant women or ones that have just given birth;</li> <li>(6) Persons with poor blood circulation such as diabetic patient;</li> <li>(7) Osteoporosis patients, individuals with spinal fractures, or those suffering from acute painful disease or injuries such as joint sprains or muscle strains;</li> </ul> | <ul style="list-style-type: none"> <li>(8) Persons with injuries should not use this product;</li> <li>(9) Persons with higher or lower regular body temperature, fever, inflammation, cold symptoms, high blood pressure, or any poor health conditions should consult a physician before using this product;</li> <li>(10) Avoid falling asleep in this chair;</li> <li>(11) Anyone with spinal or nerve conditions;</li> <li>(12) Persons with protrusion of intervertebral disc;</li> <li>(13) Do not wear loose clothing or jewelry as it might get caught with massage mechanism;</li> <li>(14) Keep long hair away from moving massage mechanism while in use.</li> </ul> |
|--|--|

Otherwise discomfort or even physical injuries may occur.



- **If you feel unwell while using or after using the chair, stop immediately and contact your doctor. Do not use the chair again unless approved by your doctor.**
- **Before operating or adjusting the chair, be sure that there are no obstructions that can cause damage to your chair. No pets or persons, near, in front, or under the chair to avoid serious injury.**
- **Before using the chair, look behind the backrest pad and inspect the area where the massage rollers move up and down for any tears or abnormal wear. Be sure the middle nylon cover is not unzipped and shows no signs of damage or tearing caused by the roller heads. Using the chair while the roller heads are exposed could cause physical injury, electrical shock, or breakage.**
- **When using the chair for the first time, it is recommended that you select the “Demo” mode to get familiar with various massage features of the chair.**
- **Do not use the chair for more than 30 minutes each time.**
- **Do not massage a single part of your body for more than 5 minutes.**
- **Ignoring these instructions may lead to discomfort or even physical injuries.**
- **After using the chair, it is recommended that the chair is unplugged from the power outlet to avoid any surges caused by outages. It is HIGHLY ADVISABLE TO ALWAYS USE A SURGE PROTECTOR. Keep children or minors from using the chair without supervision to avoid misuse that could result in serious injury.**
- **Follow the local code and regulations about use of electrical products.**
- **Use a 110V-120V, 60Hz power supply. (Do not use the chair in a country that this product is not designed for or connect it with a transformer.) It may lead to electrical shock, product failure, or internal components overheating causing fire hazard.**
- **Make sure the power cable is firmly plugged into the outlet to avoid power surges, short, and electrical shock. Electrical shock may cause internal components overheating, which can lead to a fire hazard.**
- **Wipe and clean the power plug regularly with dry cloth to avoid dirt or moisture built up.**





- **In the case of any abnormality with functions of the chair, stop using the chair immediately and pull out the power plug to avoid smoke, fire and electric shock. Abnormality and fault examples are:**
  - If the chair is plugged in, and the power switch is in the “ON” position, and if the chair is not responding.
  - When the chair is turned off but still operating.
  - If you detect any burning smell or abnormal sounds.
  - If you detect any parts of the upholstery that seemed to have melted due to over heating.
- **In any of these listed issues have occurred, STOP using the product and unplug from the power outlet. Have the product inspected by an authorized service center.**





- **Do not put any cushions or obstructions between the backrest pad and the backrest. This may damage the mechanism, and result in personal injury.**
- **When moving or handling the chair, be sure to hold onto the recommended supported area. Otherwise, parts of the chair may break resulting in serious injury.**

## ⚠ Warning





 <b>Forbidden</b>	<ul style="list-style-type: none"> <li>● People with the following health issues should NOT use this chair: Persons for whom massage is not advisable by doctors. Such as persons with thrombosis, serious aneurysm, acute venous aneurysm, various skin inflammations (such as subcutaneous tissue inflammation), or various skin infections. Otherwise, it may aggravate or cause serious injury.</li> </ul>
	<ul style="list-style-type: none"> <li>● Anyone with physical injury or poor health should NOT use this product. Persons with acute lumbago, protrusion of intervertebral disc, or displacement of a lumbar vertebra. Otherwise, it may aggravate or cause serious injury.</li> </ul>
	<ul style="list-style-type: none"> <li>● Do not put hands, arms, or feet into the traveling massage mechanism while the chair is operating.</li> <li>● Keep small children away from the chair. Climbing could result in falls leading to serious injuries.</li> <li>● Do not climb onto the backrest or the armrests.</li> <li>● Do not apply excessive pressure leaning back on the backrest.</li> <li>● Keep your head away from reachable areas of the backrest and the back cover.</li> <li>● Young individuals or those with physical disabilities who are unable to operate the chair independently, should not use this product or do so only under supervision. Anyone with weakened physical conditions should consult a doctor before using the chair.</li> <li>● When massaging the neck area, pay attention to the intensity of the massage and make sure it does not hurt the neck muscles or nerves.</li> </ul>
	<ul style="list-style-type: none"> <li>● Do not damage the power cord. Do not damage, alter, bend, twist, or use it with any extension cords. Do not place the power cord close to a heater. A damaged power cord may result in electric shock, short circuit, or fire. Please consult with the retailer/dealer from which you bought the product, or a designated authorized service center about maintaining your power cord.</li> </ul>
	<ul style="list-style-type: none"> <li>● When engaging the heat function of massage wheels, avoid prolong contact with the skin in one position. Otherwise, low-heat burns may occur. Even if the temperature is relatively lower at 104°F~140°F, low-heat burns may happen in spite of no obvious hot, or painful sensation.</li> </ul>
 <b>Wet-hand operation forbidden</b>	<ul style="list-style-type: none"> <li>● Do not insert or pull out the power plug when your hands are wet. Otherwise, electric shock may happen.</li> </ul>
 <b>Disassembly forbidden</b>	<ul style="list-style-type: none"> <li>● Do not refit, disassemble, or repair the product without the help of authorized service provider. Otherwise, fires, abnormal movement or personal injury may happen.</li> </ul>

## **Caution**

-  **Must be followed**
- The following persons (even if they are physically healthy at present) should consult a physician before using the product.
    - (1) Persons with muscular atrophy;
    - (2) Persons with any spinal condition or back pain;
    - (3) Persons suffering from sprains, or bruising easily;
    - (4) Persons with motion sickness;
    - (5) Persons who received a heart operation, or another vascular operation.It may cause serious injury if not addressed properly.
  - Before sitting on the product, make sure there is no foreign objects obstructing any part of the chair.  
(Make sure there are no foreign objects on the back cover, the backrest, the seat surface, the lower leg/foot massage section, or inside surface of the back cushion.)  
Otherwise, accidents, or injury from product failure may cause serious injury.  
Before sitting on the seat, make sure the massage wheels are in the retracted positions.
  - Turn off the massage function before you get off the chair.
  - When the lower leg/foot massage section is not retracting after the massage, retract the footrest with the remote button.
  - When unplugging the chair, hold onto the head of the plug and not the cord to avoid damaging to the power cord. Damaged cord could result in electric shock and serious injury.
  - Before moving the chair, be sure the backrest is in the upright position and the footrest is retracted in default positions.  
Otherwise, injury may happen or damage to the chair.
  - When moving the product by dolly, lay mats on the floor to avoid markings or damage to the floor. Do not roll the chair on engineered wood or soft wood floorings. Otherwise, marks and damage may occur.
  - Keep the safety lock key.  
Keep children away from the remote control.
  - Before moving the chair, make sure there are no obstructions around. If lifting is required, make sure to lift from the steel frame of the chair. Be sure to keep the chair in the upright position when lifting the chair when moving.
  - Symptoms such as skin inflammation, itching, or swelling when using the chair, stop using the product immediately and consult a physician.

-  **Forbidden**
- Do not use the product with other electrical devices at the same time, such as a heating blanket.
  - Do not place your hands, arms, feet, or any parts of your body in the massage area that are not designed for the body parts to avoid discomfort or injury.
  - Do not put the knees between the calf massager. This may cause serious injury.
  - Do not fall asleep while using the product.
  - Do not use the product after drinking alcohol.
  - If the airbag on the seat is not completely deflated, do NOT attempt to deflate the air bag by force or using any tools. Contact the manufacturer to resolve the matter.

## ⚠ Caution

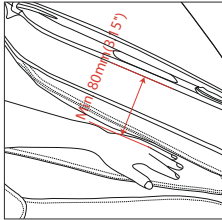
 <b>Forbidden</b>	<ul style="list-style-type: none"> <li>● Do not put hands or feet between footrest and seat base.</li> <li>● Do not put hands or feet between footrest and side panel.</li> <li>● Do not put hands or feet between seat base and side panel.</li> <li>● Do not put hands or feet between the upper and the lower part of the footrest.</li> <li>● Do not put hands or feet in the gap of seat base.</li> <li>● Do not put pets on the massage chair.</li> <li>● Do not pull out the power plug or turn off the power switch suddenly during massage operation.</li> </ul>
	<ul style="list-style-type: none"> <li>● Do not stand or sit on the backrest. This may lead to serious injury and damage to the product.</li> </ul>
	<ul style="list-style-type: none"> <li>● Do not stand or sit on the armrests.</li> </ul>
	<ul style="list-style-type: none"> <li>● Do not stand or sit on the lower leg/foot massage section or the footrest.</li> </ul>
	<ul style="list-style-type: none"> <li>● Do not drag or push the product after it is installed.</li> </ul>
	<ul style="list-style-type: none"> <li>● Do not move the product while there is a person sitting on it.</li> </ul>
	<ul style="list-style-type: none"> <li>● Do not use the product with other heating devices such as electric blankets. Otherwise, fire may occur due to overheating.</li> </ul>
	<ul style="list-style-type: none"> <li>● Do not leave the remote controller on the seat, always return it to its holder.</li> </ul>
 <b>Wet-hand contact forbidden</b>	<ul style="list-style-type: none"> <li>● Do not place this chair in locations with high humidity such as the bathroom. Moisture will destroy electrical components resulting in product failure or worst, electrical shock, and other serious injury.</li> </ul>
 <b>Product wetting forbidden</b>	<ul style="list-style-type: none"> <li>● Do not use any liquid aerosol sprays around the chair. Otherwise, electric shock, fire, short circuit, or product failure may happen.</li> </ul>
 <b>Pull out the power plug</b>	<ul style="list-style-type: none"> <li>● Before cleaning or maintaining the product, always unplug the power cord.</li> </ul>
	<ul style="list-style-type: none"> <li>● In the case of a power failure, pull out the power plug at once. It is highly recommended to plug chair into a surge protector to protect the chair from shorting during outages.</li> </ul>
	<ul style="list-style-type: none"> <li>● When the product is not in used, pull out the power plug.</li> </ul>
<p><b>Warning:</b></p> <p>When using the massage chair, the arm should not be placed on the wireless charger. The minimum distance between the arm and the wireless charger is 80mm(3.15").</p> <div style="text-align: right;">  </div>	

## GROUNDING INSTRUCTIONS

This product must be grounded. If it malfunctions or break down, grounding provides a path of least resistance for the electric current to reduce the risk of electric shock. This product is equipped with a cord with an equipment-grounding conductor and a grounding plug. The plug must be plugged into an appropriate outlet that is properly installed and grounded in accordance with all local codes and ordinances. **Danger** Improper connection of the equipment-grounding conductor can result in a risk of electric shock. Check with a qualified electrician or serviceman if you are in doubt as to whether the product is properly grounded. Do not modify the plug provided with the product – if it will not fit the outlet, have a proper outlet installed by a qualified electrician.

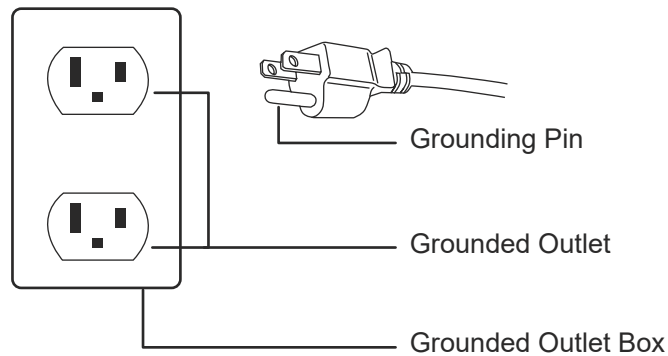

# About Chair

## External Side Structure 1



# External Side Structure 2



## External Side Structure 3

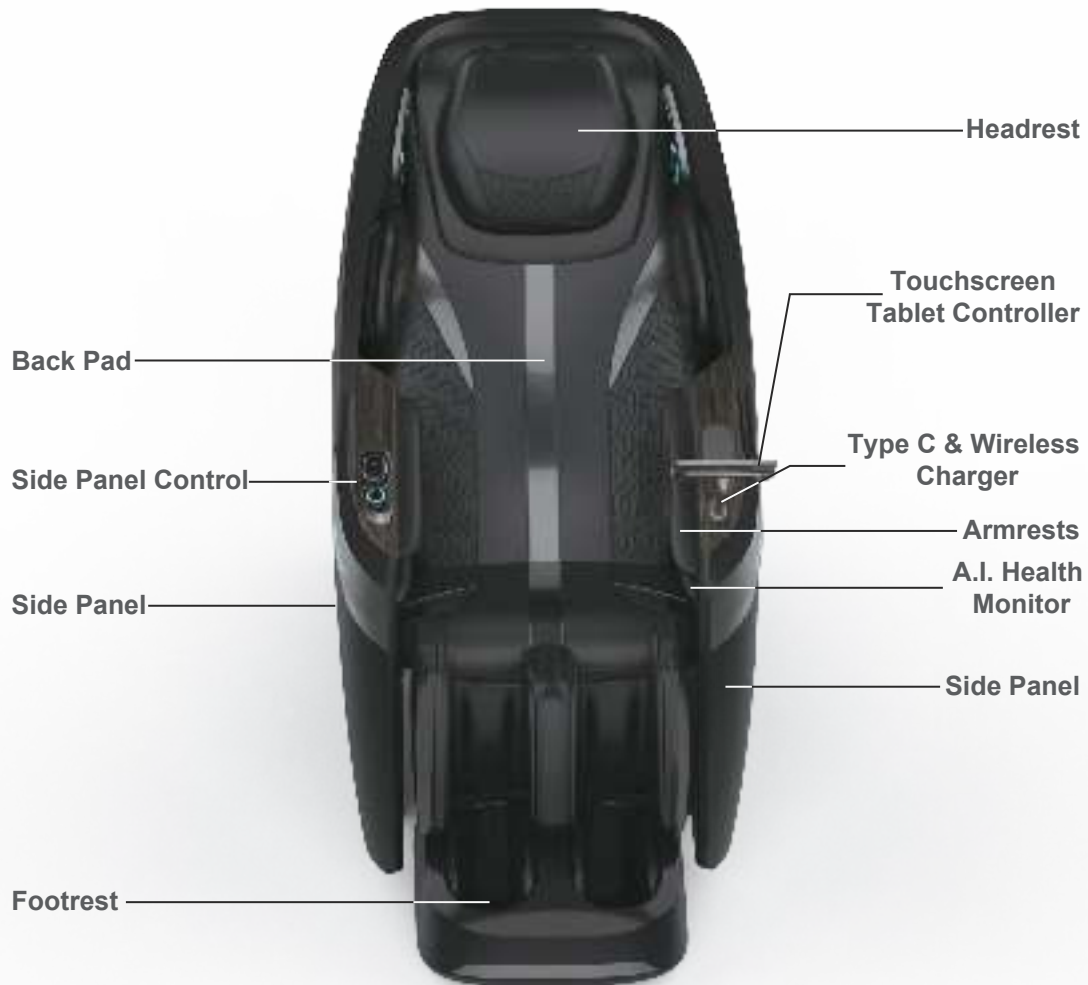

**Note: The Monster speakers will only function when the massage chair is in use.**









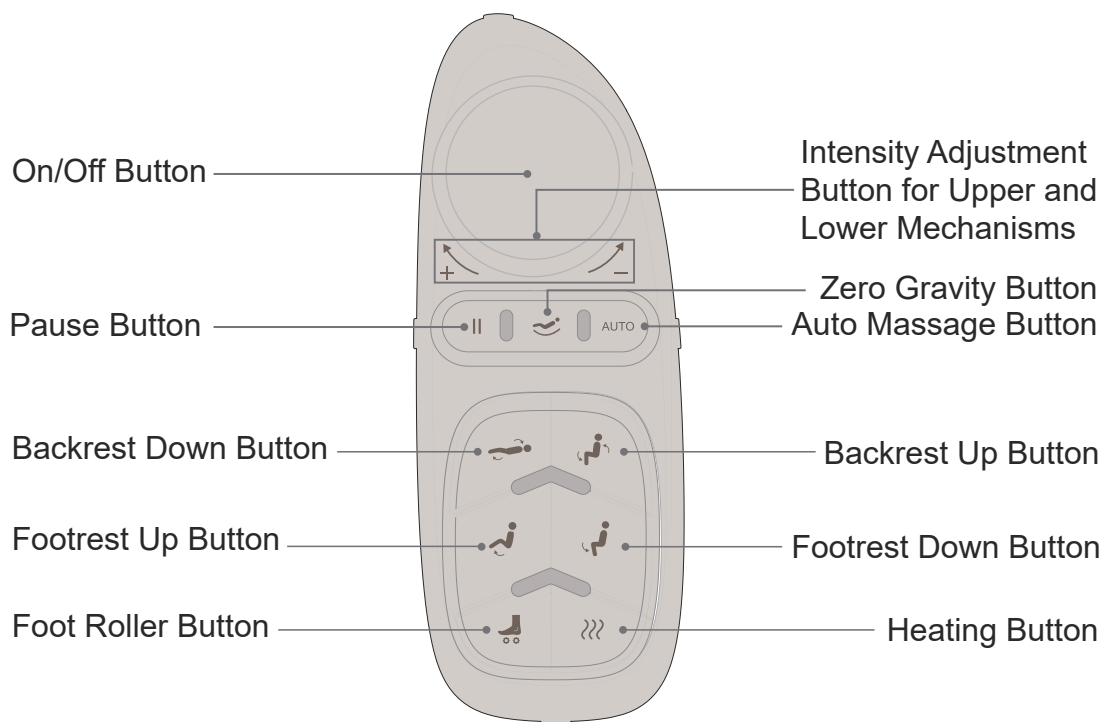

- To play music through your massage chair's speakers, please connect your smartphone, tablet, or other compatible electronic device to your chair via Bluetooth. Please note that the Bluetooth connection code is "Somnus 4D".
- Make sure you disconnect the Bluetooth after using so the next user can connect it.

## Airbags Position & Numbers



## Side Panel Control Instructions



	<p><b>On/Off</b></p> <ul style="list-style-type: none"> <li>• When in off state, press this button to turn the chair on; press it again to turn it off and chair will return to the original state.</li> </ul>
	<p><b>Intensity Adjustment Button for Upper and Lower Mechanisms</b></p> <ul style="list-style-type: none"> <li>• Increase the intensity by rotating the button in the clockwise direction and decrease the intensity by rotating counter clockwise.</li> </ul>
	<p><b>Pause Button</b></p> <ul style="list-style-type: none"> <li>• Press this button to pause the massage, while press it again to continue massage.</li> </ul>
	<p><b>Zero Gravity Button</b></p> <ul style="list-style-type: none"> <li>• Press this button to enter zero gravity mode.</li> </ul>
	<p><b>Auto Massage Button</b></p> <ul style="list-style-type: none"> <li>• Press this button to enter the recommended auto massage program.</li> </ul>
	<p><b>Backrest Down Button</b></p> <ul style="list-style-type: none"> <li>• Press this button to recline the backrest.</li> </ul>
	<p><b>Backrest Up Button</b></p> <ul style="list-style-type: none"> <li>• Press this button to raise the backrest.</li> </ul>
	<p><b>Footrest Up Button</b></p> <ul style="list-style-type: none"> <li>• Press this button to raise the footrest.</li> </ul>
	<p><b>Footrest Down Button</b></p> <ul style="list-style-type: none"> <li>• Press this button to lower the footrest.</li> </ul>
	<p><b>Foot Roller Button</b></p> <ul style="list-style-type: none"> <li>• Press this button to turn on or off the foot roller function.</li> </ul>
	<p><b>Heating Button</b></p> <ul style="list-style-type: none"> <li>• Press this button to turn on or off the heating function.</li> </ul>

## Things To Do And Know Before Use

### Place Position

- Please place the chair in desired flat location nearing to the power outlet.
- Please keep 6.9" clearance for the recline of the backrest and 24.8" clearance for the extension of footrest and make sure enough room for the user to get in and out of the chair freely.
- It is recommended to place a sacrificial pad or mat under the product to protect the floor. The suggested dimension of the pad or mat is 63"x31.5".

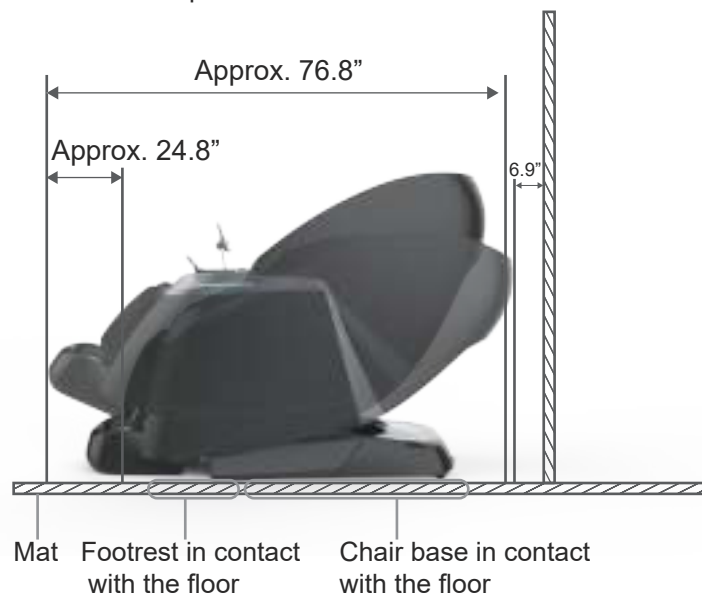

#### Warning

- Do not place the massage chair in high moisture environment such as near a swimming pool or bathroom to prevent electric shock accident.
- Do not place the massage chair directly under the sunlight or near the heated surfaces to prevent fabric fading, discoloration, hardening deterioration, or fire hazard that could damage the product.

# Things to Check Before Use

## 1 Check All Around The Chair

Check all around the chair to make sure there are no children, pets, or any other objects near the footrest and the back area of the chair. Otherwise, the chair may not function properly.



## 2 Make Sure No Foreign Objects Inside or in the Gaps between the Chair

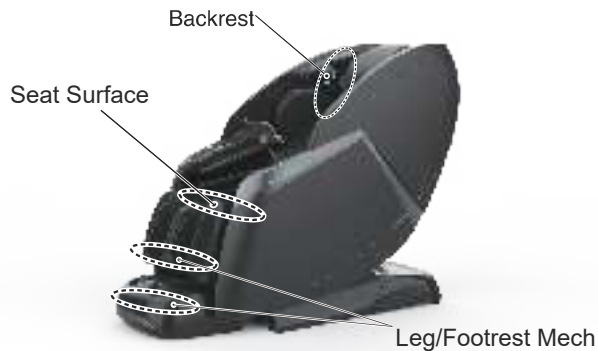

### **Caution**

- Do not put hands, feet, or any other foreign objects between the footrest and the seat base.
- Do not put hands, feet, or any other foreign objects between the footrest and the side panel.
- Do not put hands, feet, or any other foreign objects between the seat base and the side panel.
- Do not put hands, feet, or any other foreign objects between the upper and the lower part of the footrest.
- Do not put hands, feet, or any other foreign objects in the gaps of the chair. Otherwise, injury may occur.

### 3 Make Sure The Fabric Is In Good Condition, With No Damage, Tears, Or Cracks

Focus on inspecting the fabric where the massage wheels on the backrest move.



#### **Warning**

- Before using, please raise the back pad and inspect the fabric highlighted in the diagram to ensure it's not damaged. In the event of any fabric damage, even minor, discontinue use of the product immediately. Unplug the power cord and contact the local service department to request a replacement. Using the product with damaged fabric may result in injury or electrical shock.

### 4 Ensure That The Massage Rollers Are Positioned Correctly



Before using, please check, and ensure that the upper mechanism rollers are positioned correctly at the top of the backrest, while the lower mechanism rollers are positioned at around the lower back, as shown in the picture. If both rollers are incorrect, please press the power switch to reset them to the default position.

## 5 Carefully Inspect The Power Cord & The Power Plug

### Warning

- Inspect the power cord for dirt and dust, as these can cause electrical fires. Keep it clean and damage-free; wipe the plug with a dry cloth.
- Avoid damaging, bending, or twisting the cord.
- Never place it under heavy objects, or near heat sources. Damaged cords can lead to electric shock, short circuits, or fire.
- For maintenance, consult the store where you bought the product or an authorized service center.



Ensure that the plug is fully inserted into the chair's port, and keep the power cord untangled to avoid any potential damage.

## 6 How To Power on the Chair

- 1 Plug the power cord into the electrical outlet.
- 2 Turn the switch to the "I" position to turn the chair on.

### Warning

- Ensure the power cord is securely plugged into the outlet to prevent overheating, short circuits, electric shock, or fire.
- Adhere strictly to socket and wiring regulations, using a 110-120V~, 60Hz power supply.
- Do not use the product overseas, or with unauthorized transformers to avoid shocks, malfunctions, or fires.
- Never plug or unplug with wet hands to prevent electric shock.

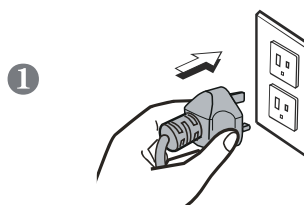

## How To Use

### Adjust The Headrest

- Sit as far back as you can in the chair and take note of where the headrest rests on your neck. Adjust the headrest so that it rests comfortably in the arch of your neck, flip it up out of the way, or use the zipper to remove it all together.



### Activate The Massage Chair

You can use the following two ways to turn on the chair.

## 1. Method 1



By pressing the switch button on the tablet remote.

## 2. Method 2



By pressing the power button on the dial control.

When turning on the chair, you will see the chair brand “Osaki Platinum” showing up on the screen.



# Operational Instructions

## Home Page

This is the initial screen that will appear on the tablet controller. From this screen, you can access all the menu options. Just tap the screen with your finger to make a selection. For each item on the homepage, please see the detailed definitions below.



- 1. User Account
- 2. Add User or Switch User
- 3. Settings
- 4. Pause Massage Button
- 5. Power Off Button
- 6. Auto massage programs
- 7. Manual massage programs

- 8. Customized health message programs based on body condition
- 9. Personalized massage programs
- 10. Stretch massage programs
- 11. Chair position and angle adjustment
- 12. Personal health check data
- 13. Personal favorite message programs

## User Account

For a more tailored and enjoyable chair experience, it's better to create and log in to an account first. It grants quick access to your settings and tracks benefits over time. Each user can have their own account for personalization.



**Note:** Before registering your account and since it's your first time using the tablet controller, please go to "Settings" to connect a network. Select a network that you would like to connect, enter the password, and start using it to its full potential.

## User Registration & Login Guide

Register to become a user and then login securely to enjoy a consistent and tailored relaxation experience every time.



The Register screen features a dark background with a central white rounded rectangle. At the top, the word "Register" is displayed. Below it, there are three input fields: "Please enter an email" with an envelope icon, "Please enter the verification code" with a document icon and a "Obtain verification code" button, and "Please enter the password" with a lock icon and a visibility toggle. A green checkmark and the text "Agree User License And License Agreement" are positioned above a large "Register" button. At the bottom, a link reads "Already have an account? Log in now".

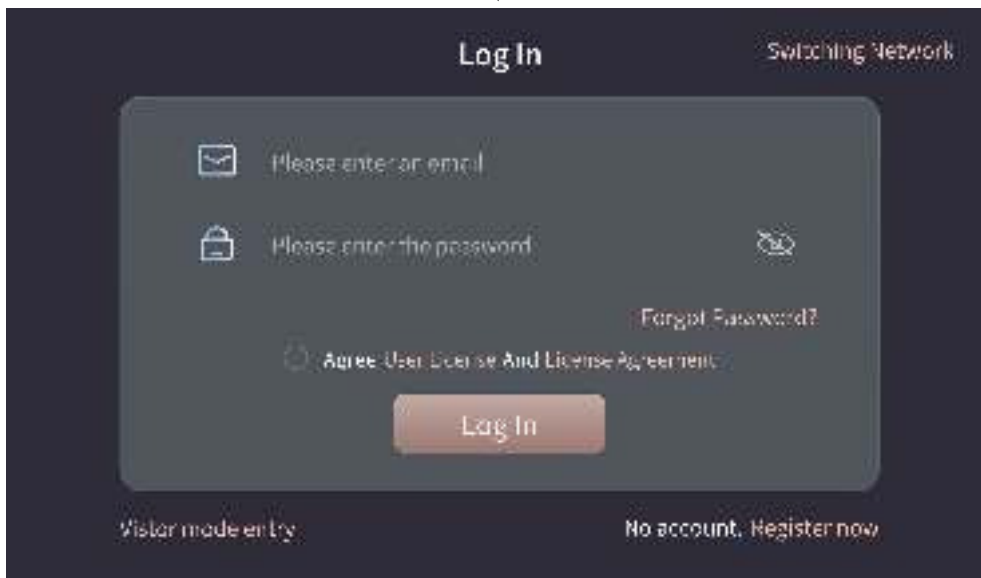

The Log In screen has a dark background with a central white rounded rectangle. At the top, "Log In" is centered, and "Switching Network" is in the top right. The form includes two input fields: "Please enter an email" with an envelope icon and "Please enter the password" with a lock icon and a visibility toggle. A "Forgot Password?" link is located to the right of the password field. Below the fields is a radio button and the text "Agree User License And License Agreement". A large "Log In" button is centered at the bottom. At the very bottom, the text "Visitor mode on try" is on the left and "No account, Register now" is on the right.

- For registration, please enter your email address, the verification code sent to your email, and create a password. Be sure to review and agree to the User License and License Agreement before tapping "Register". To login, navigate to the Login interface and input your email address along with your password. In case you forgot your password, simply click "Forgot Password?" to reset it. If you're already registered, you can skip the registration process and log in directly.

**Note:** Users have the option to use "Visitor Mode" without logging in, but please note that this mode does not allow for saving personal information, program preferences, or health check data.

## Personal Information Setup

Fill in personal info to let the chair tailor services to your body type.

The screenshot shows a mobile application interface for setting up a user profile. At the top left, there is a back arrow. Below it is a profile picture placeholder with a circular arrow and the word "Edit". To the right of the profile picture are two buttons: "Male" with a blue male symbol and "Female" with a red female symbol. Below these are four input fields: "Nickname" with "User" entered, "Birthday" with "Please select (required)", "Weight" with "Please select (required)" and "LBS" on the right, and "Height" with "Please select (required)" and "IN" on the right. A large orange button is partially visible at the bottom center.

- Select a profile picture. Input your nickname and choose your gender. Then fill in other details such as name, birthday, height, and weight.

## Auto Body Scanning

The massage chair automatically detects your body. When powered on for the first use, it starts detection once any massage program is selected, locating your shoulders for precise, targeted massage.

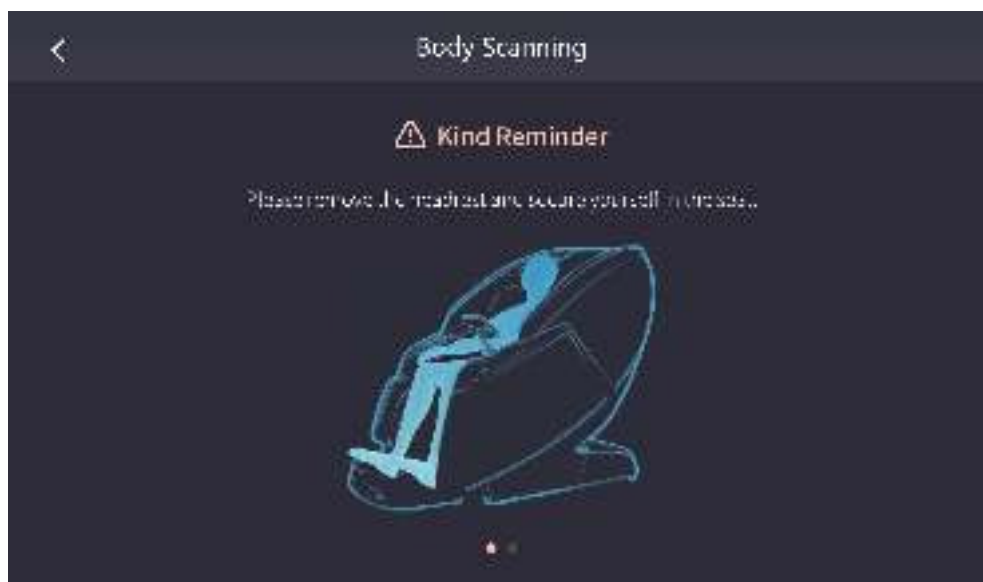



- During body scanning, follow on-screen instructions. After completion, verify the shoulder position. Adjust manually if necessary; tap "Confirm" if not. Otherwise, the detected shoulder position will be adopted, and the chair will automatically proceed to the next interface in 10 seconds.

## Auto Massage

The chair is equipped with 20 auto massage programs organized into 5 main categories. Each category features 4 dedicated programs, providing diverse massage experiences tailored to different relaxation needs.









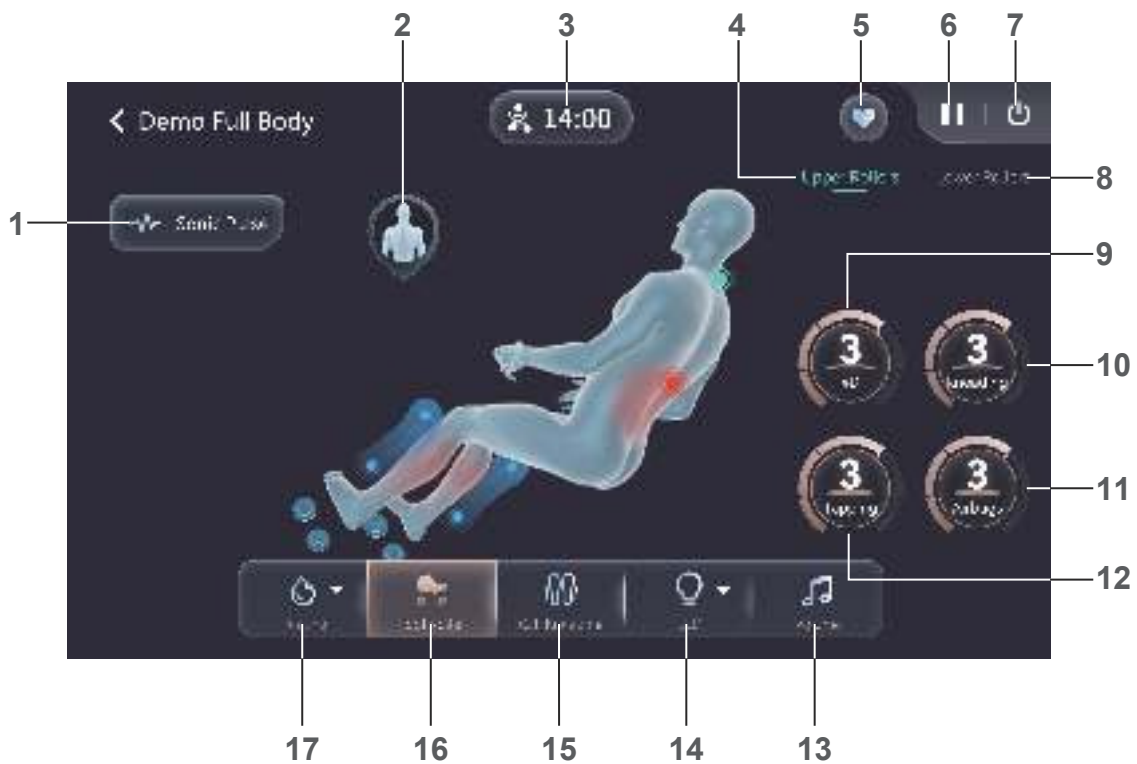





- Choose an auto massage program and customize it with extra functions like foot rollers, heating, calf kneading, and lighting for an enhanced experience. Refer to the function definitions below.









## Function Definitions



1. Applicable for both upper and lower mechanisms. Activate the function by tapping once, and deactivate it by tapping again.
2. Tap it to observe where the rollers move across the back of the body.
3. Massage program's time.
4. Refers to the upper mechanism's massage.
5. Tap to save the auto massage program as one of your favorites.
6. Pause massage.
7. Power off button.
8. Refers to the lower mechanism's massage.
9. Adjust the massage intensity up to 5 levels.
10. Adjust the kneading strength up to 5 levels.
11. Adjust the airbags' pressure up to 5 levels.
12. Adjust the tapping strength up to 5 levels.
13. Tap it to adjust the volume of the Monster bluetooth speakers. Total of 5 adjustments.
14. Tap to enter the LED selection interface, and please ensure that the LED is turned on in order to select a color.
15. Tap it to turn on the calf kneading while tap it again to turn it off.
16. Tap it to turn on the foot rollers' function. Tap it again to deactivate the function.
17. Tap it to select back rollers heating, lumbar heating, as well as calf heating.

## Auto Massage Programs' Definitions

	<p><b>Demo Full Body</b></p> <ul style="list-style-type: none"> <li>• A demonstration-based full body preset showing the chair's functions and techniques.</li> </ul>
	<p><b>Smart Care</b></p> <ul style="list-style-type: none"> <li>• An intelligent preset analyzing the body and providing personalized massage with suitable techniques.</li> </ul>
	<p><b>Body Circulation</b></p> <ul style="list-style-type: none"> <li>• A preset promoting blood flow, relieving fatigue, and enhancing physical performance.</li> </ul>
	<p><b>Gentle</b></p> <ul style="list-style-type: none"> <li>• A preset with light massage techniques, offering a mild, soothing massage for relaxation, or sensitive users.</li> </ul>
	<p><b>Morning Care</b></p> <ul style="list-style-type: none"> <li>• A preset massage program with various techniques to ease morning muscle stiffness, improve circulation, and boost your mood for a fresh start.</li> </ul>
	<p><b>Midday Care</b></p> <ul style="list-style-type: none"> <li>• A mode for midday use, relieving fatigue, easing tension, and promoting relaxation to recharge.</li> </ul>
	<p><b>Night Care</b></p> <ul style="list-style-type: none"> <li>• A specialized preset for night time, inducing deep relaxation, calming the body and mind, and enhancing sleep quality.</li> </ul>
	<p><b>Fatigue</b></p> <ul style="list-style-type: none"> <li>• A preset mode targeting physical tiredness, soothing muscles, reducing soreness, and restoring vitality.</li> </ul>
	<p><b>Calm</b></p> <ul style="list-style-type: none"> <li>• A mode using gentle techniques to create a stress-free, tranquil experience, and calm the nervous system.</li> </ul>
	<p><b>Recover</b></p> <ul style="list-style-type: none"> <li>• A mode repairing muscle tissues, improving flexibility, and rejuvenating the body after exertion.</li> </ul>
	<p><b>Care</b></p> <ul style="list-style-type: none"> <li>• A hands-free mode combining massage techniques to deliver relaxation and therapeutic benefits.</li> </ul>

	<p><b>Relax</b></p> <ul style="list-style-type: none"> <li>• A mode with gentle strokes and pressures to release muscle tightness and provide deep stress relief.</li> </ul>
	<p><b>Men's Health</b></p> <ul style="list-style-type: none"> <li>• A specialized preset meeting men's relaxation needs, relieving tension, and enhancing physical wellbeing.</li> </ul>
	<p><b>Women's Health</b></p> <ul style="list-style-type: none"> <li>• A customized preset addressing women's specific health and relaxation needs, soothing muscles, and reducing stress.</li> </ul>
	<p><b>Deep Tissue</b></p> <ul style="list-style-type: none"> <li>• A preset applying firm pressure to reach deep muscles, alleviating chronic pain and tension.</li> </ul>
	<p><b>Thai Stretch</b></p> <ul style="list-style-type: none"> <li>• A preset inspired by Thai massage, using stretches, and compressions to improve flexibility and joint mobility.</li> </ul>
	<p><b>Neck &amp; Shoulder</b></p> <ul style="list-style-type: none"> <li>• A preset targeting neck and shoulders, relieving stiffness, and soreness with various techniques.</li> </ul>
	<p><b>Lumbar Care</b></p> <ul style="list-style-type: none"> <li>• A preset for the lower back, relieving pain, relaxing muscles, and improving spinal flexibility.</li> </ul>
	<p><b>Waist &amp; Hips</b></p> <ul style="list-style-type: none"> <li>• A preset mode reducing muscle fatigue, enhancing circulation, and improving flexibility in the waist and hips.</li> </ul>
	<p><b>Waist &amp; Legs</b></p> <ul style="list-style-type: none"> <li>• A preset focusing on waist and legs, relieving soreness, improving blood flow, and enhancing lower body condition.</li> </ul>

## Manual Massage

This chair not only provides you with preset auto massage programs, but also offers a rich variety of massage techniques that you can manually select from dual mechanisms and combine to enhance your massage experience.







- For definitions of other massage functions within the ongoing manual massage programs, please refer to the Function Definitions mentioned in the auto massage programs.

## Manual Massage Modes

Mechanism Name	Category	Message Mode	
Upper Mechanism	19 Single Message Modes	Kneading 1, 2	
		Scraping 1, 2	
		Clapping 1, 2	
		Shiatsu 1, 2	
		Tapping 1, 2	
		Swedish 1, 2	
		Rolling 1, 2	
		Pressing 1	
		Pointing 1	
		Soothing 1	
		Dialing 1	
		Knocking 1	
		48 Double Combined Message Modes	Kneading 1, 2 x Clapping 1, 2
			Kneading 1, 2 x Shiatsu 1, 2
	Kneading 1, 2 x Tapping 1, 2		
	Kneading 1, 2 x Rolling 1, 2		
	Scraping 1, 2 x Clapping 1, 2		
	Scraping 1, 2 x Shiatsu 1, 2		
	Scraping 1, 2 x Tapping 1, 2		
	Scraping 1, 2 x Rolling 1, 2		
	Clapping 1, 2 x Rolling 1, 2		
	Shiatsu 1, 2 x Rolling 1, 2		
	Tapping 1, 2 x Rolling 1, 2		
	Swedish 1, 2 x Rolling 1, 2		
	48 Three-combined Message Modes		Kneading 1, 2 x Clapping 1, 2 x Rolling 1, 2
			Kneading 1, 2 x Shiatsu 1, 2 x Rolling 1, 2
		Kneading 1, 2 x Tapping 1, 2 x Rolling 1, 2	
		Scraping 1, 2 x Clapping 1, 2 x Rolling 1, 2	
		Scraping 1, 2 x Shiatsu 1, 2 x Rolling 1, 2	
		Scraping 1, 2 x Tapping 1, 2 x Rolling 1, 2	
	Lower Mechanism	13 Single Message Modes	Kneading 1, 2
			Shiatsu 1, 2
			Swedish 1, 2
			Tapping 1, 2
			Clapping 1, 2
			Scraping 1, 2
			Rolling 1
		12 Double Combined Message Modes	Kneading 1, 2 x Clapping 1, 2
			Kneading 1,2 x Shiatsu 1, 2
			Kneading 1, 2 x Tapping 1, 2

## Health Check Massage

The chair provides you with A.I. health check detection, including comprehensive health index, blood oxygen, microcirculation, heart rate, and HRV. Also it can customize an exclusive health massage program based on your personal health condition.

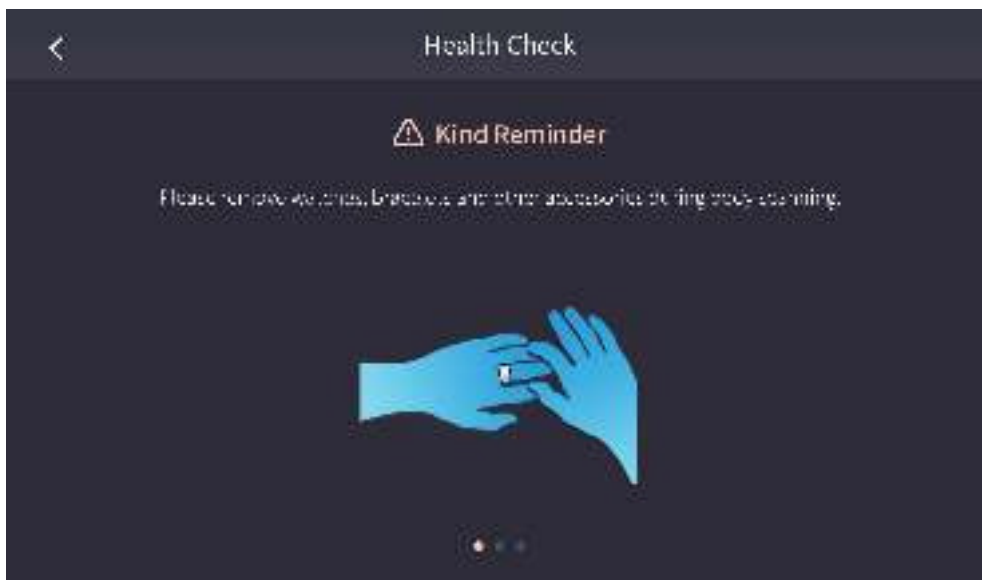

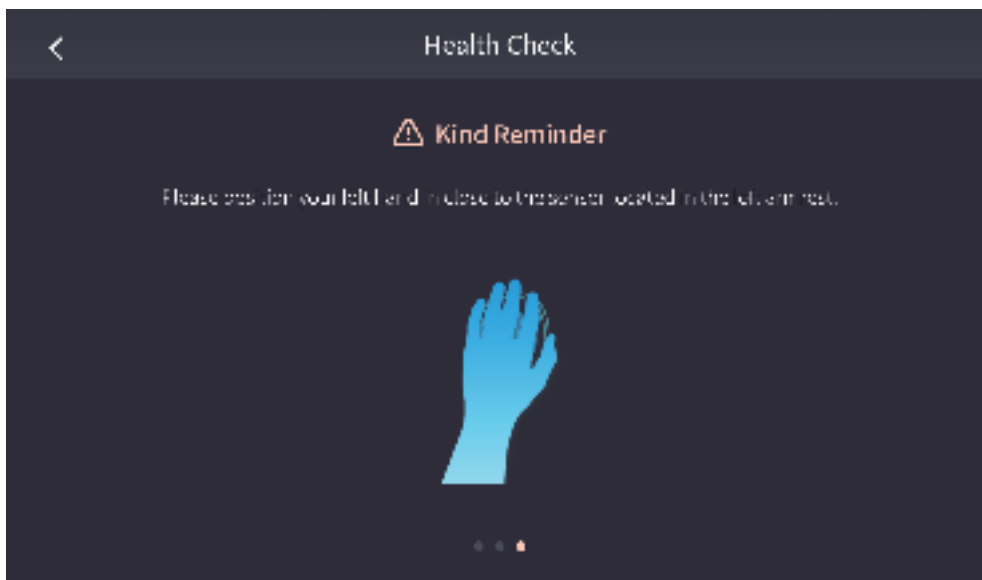

EN 39



EN 40



- Please follow the prompts on the screen to perform the health check detection, ensuring that your left hand remains tightly pressed against the health monitor and hold still, so as to complete the health check detection.

**Note:** The detection data is for reference only. If you feel unwell, it is recommended to consult your doctor.

# Custom Massage

The chair designs Custom Massage for every unique individual. You can customize your own exclusive massage program according to your needs.

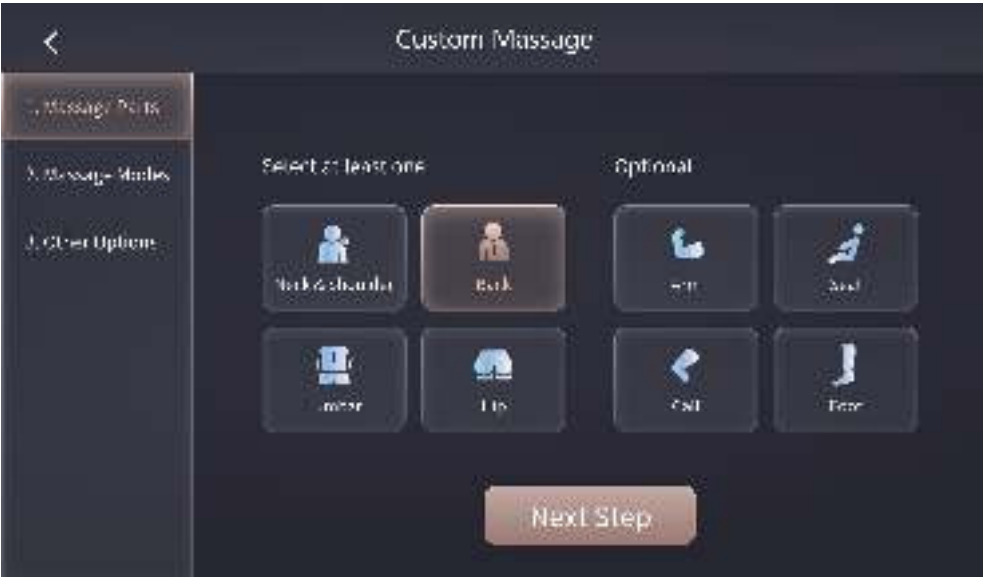

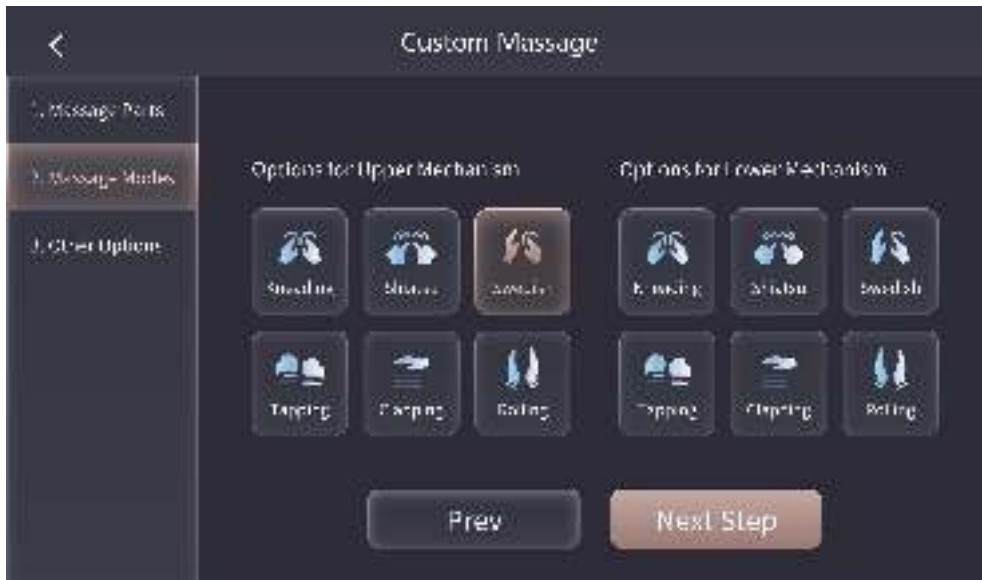



- According to the screen guidance, tap on the parts where you want to have a massage, and select the massage modes of the upper and lower mechanisms. Tap "Next Step" to go to the next interface, select other functions and LED lighting options, then tap "Confirm", and a custom massage program will be generated.

## Stretch Massage

Considering that some people like stretching, the chair is designed with partial and full-body stretching massage programs, allowing you to have more choices and massage experiences.





- Tap to select “Isolation Stretch” or “Full-Body Stretch”, and you can turn on or off the heating therapy to start your stretch massage experience.

**Note:** During the stretch massage program, you cannot adjust the seat of the chair.

# Seat Adjustment



## Seat Adjustment Guide

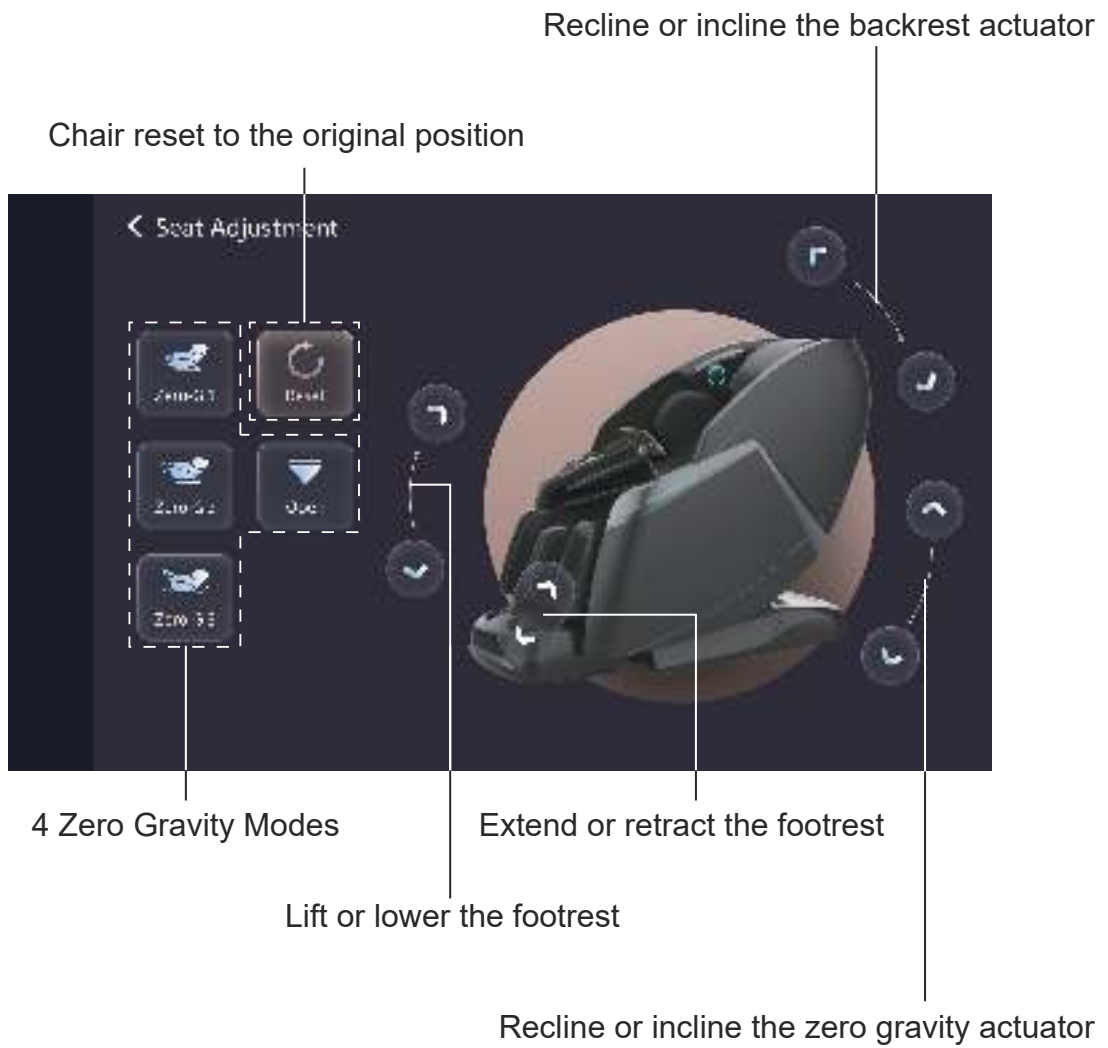

**Note:** When you are having stretch massage program, you can't adjust the seat of the chair.

## Health Records

For your convenience to check your own health check status, you can view your data here at any time.

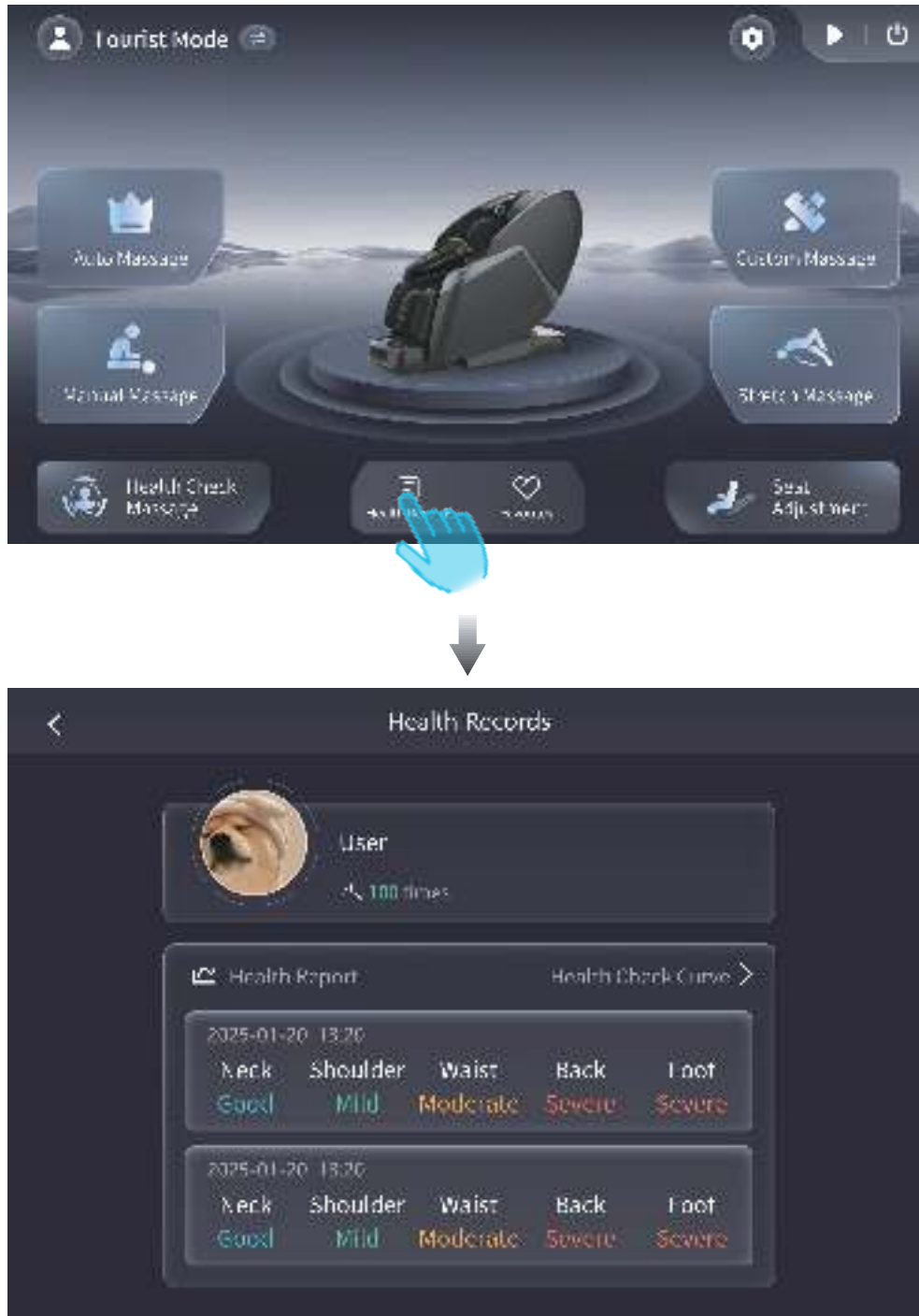

- You can check your massage times, health report, and health check curve.

## Favorites

Save your favorite message programs to the Favorites for quick access and simply tap to start your massage.

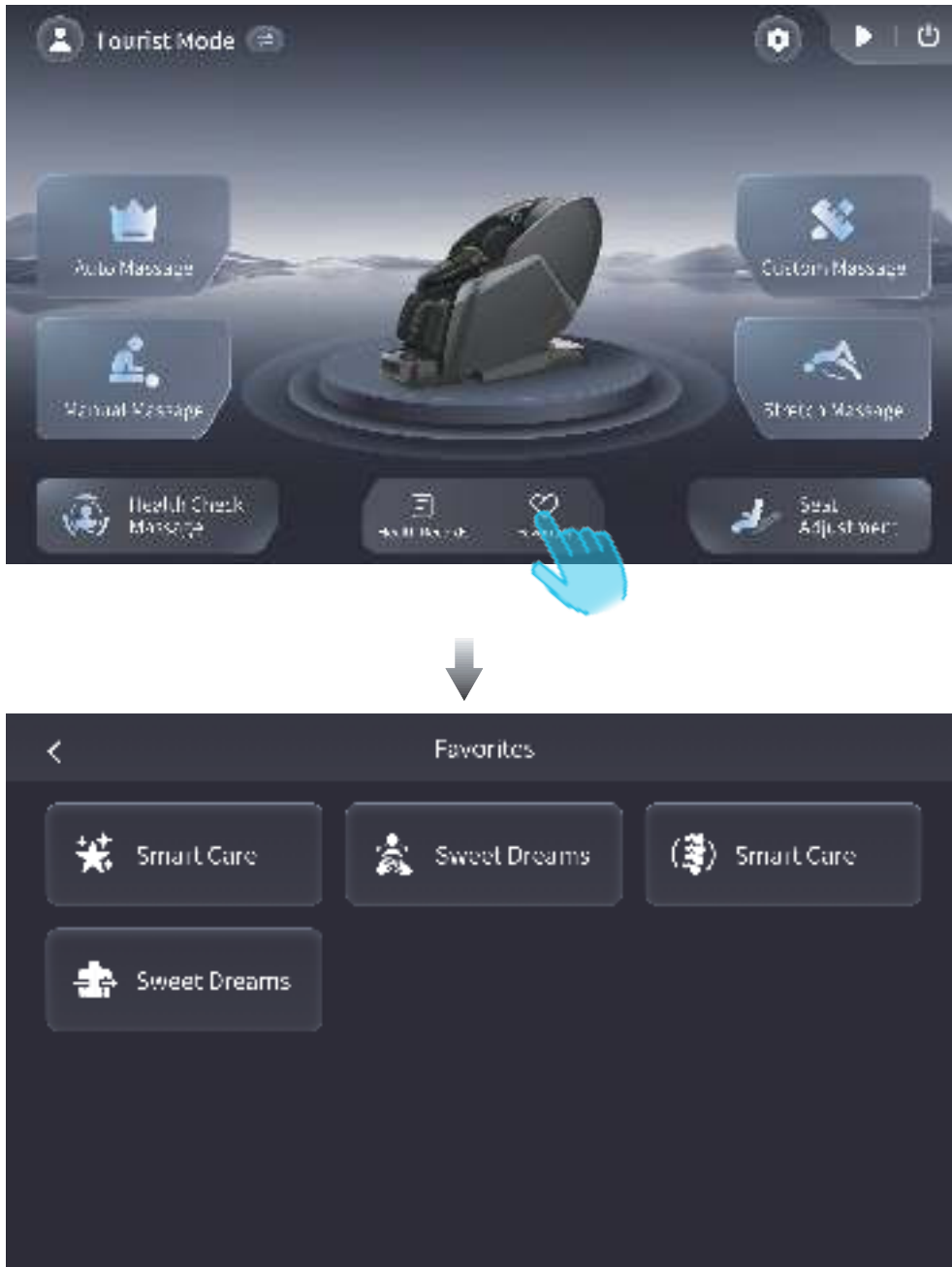

- Tap a saved program to start your massage instantly. To remove a program you don't like, long-press it to delete.

## Settings

For other chair settings, simply tap to configure them.

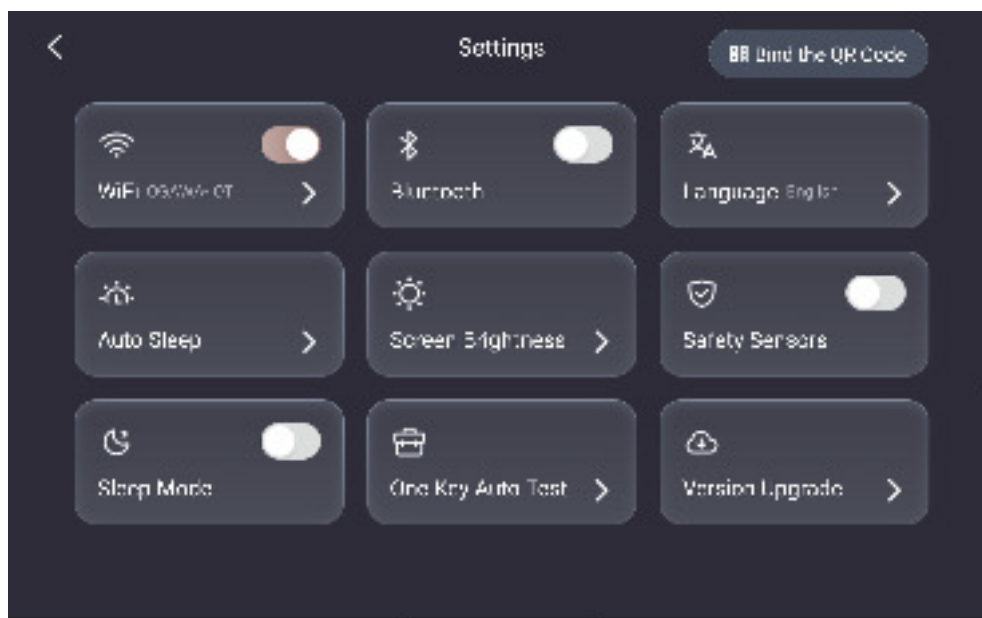

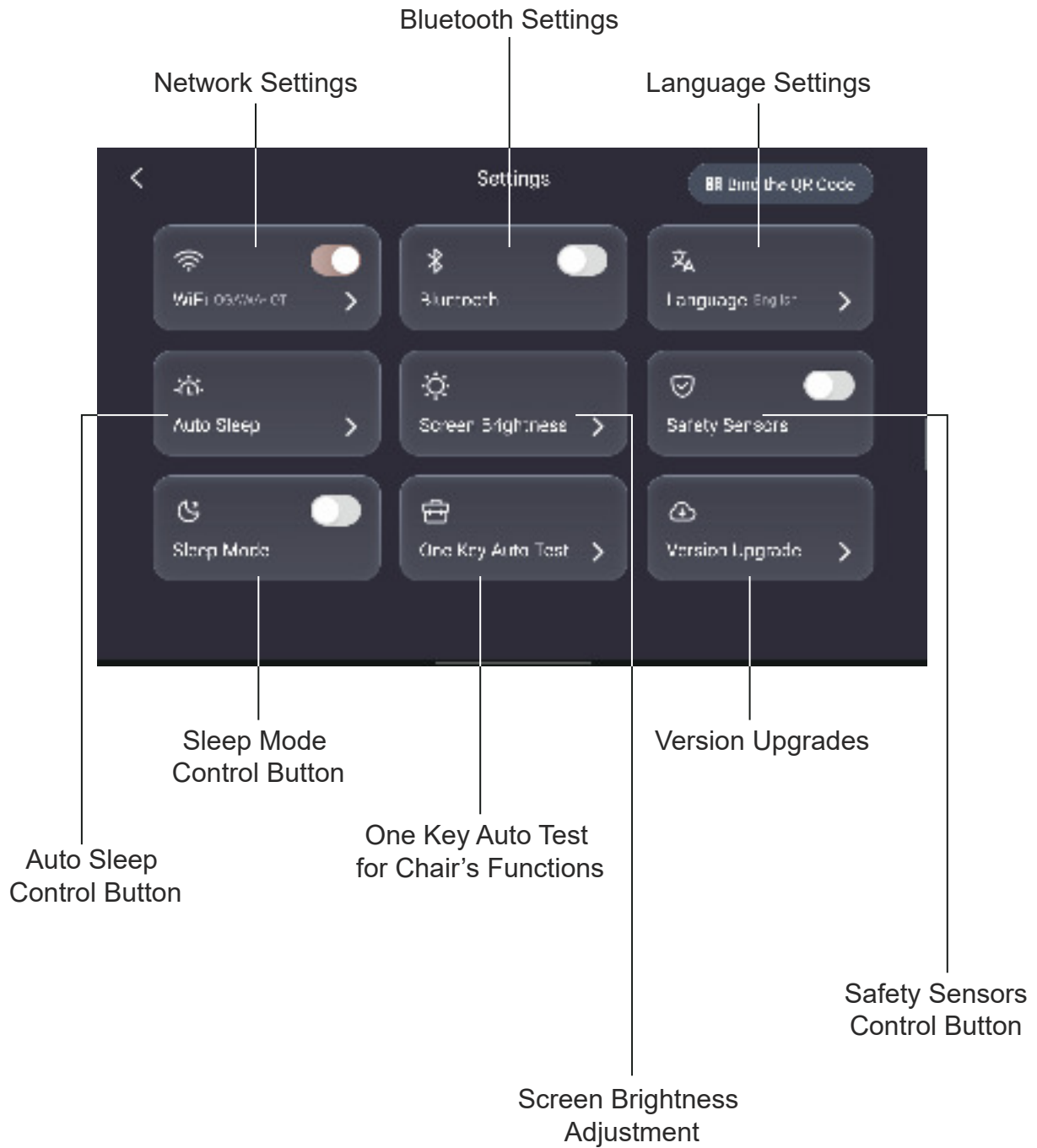

## Safety Sensors

The chair is equipped with safety sensors. If there's something detected around the footrest and the back area of the chair, a warning message will pop-up like below.



- Please check and clear the area. Tap "OK" to select a massage program to continue.

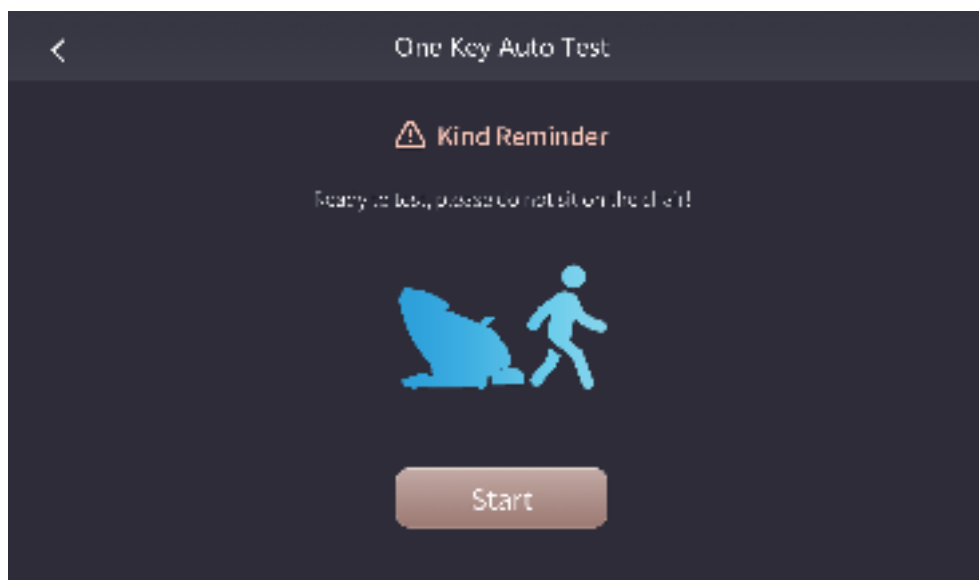
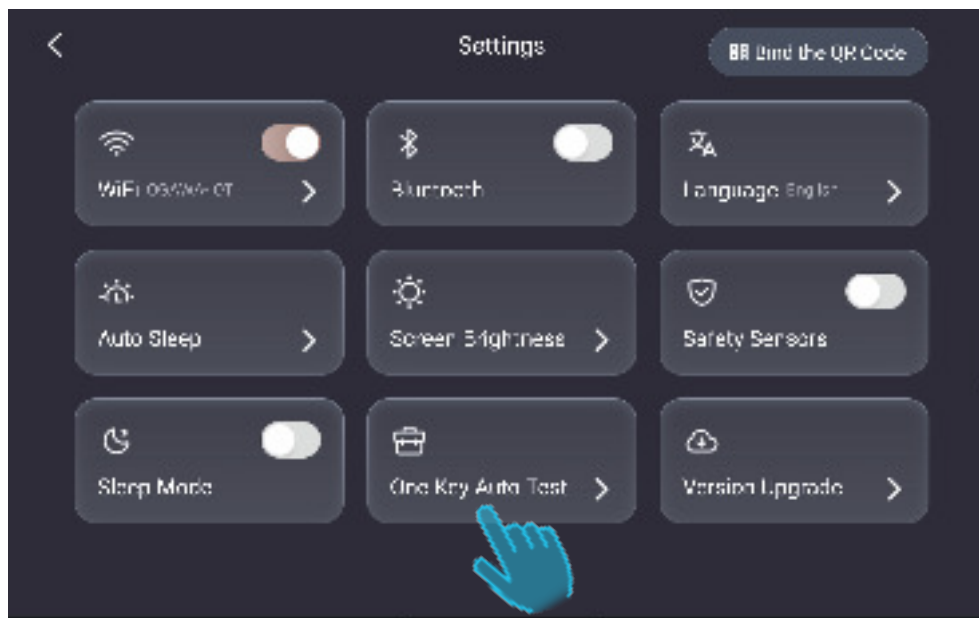

## One Key Auto Test

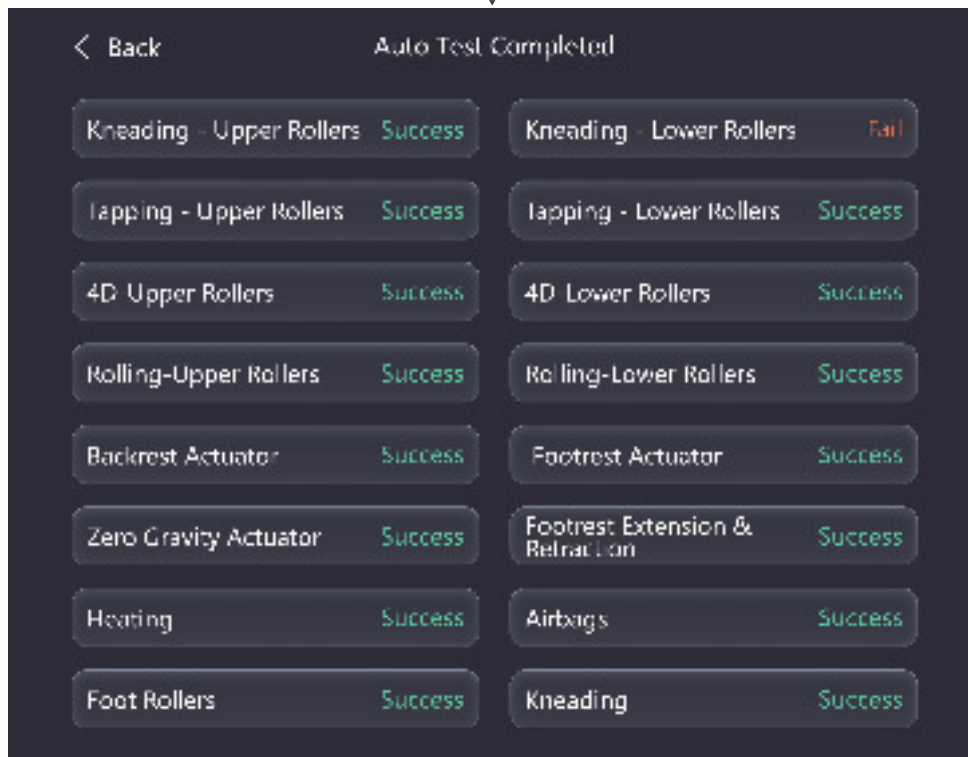
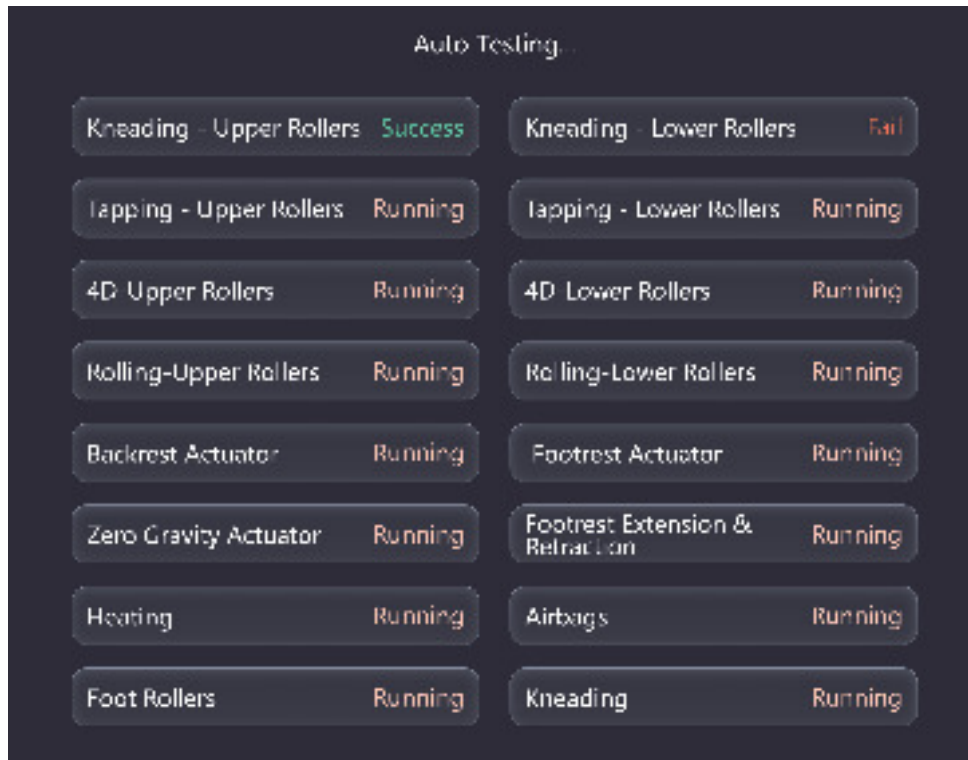



- Before testing the chair, it is suggested not to sit on the chair. Tap 'Start' to begin the functions' test. You can see whether all functions of the chair are normal.

## After Massage

1. First double-check to make sure there are no people or any other things around the chair, such as a child, a pet, or any other object.
2. Power off the chair by using the following three operating ways.
  - Press the power switch on the right top of the touchscreen controller.
  - Tap the power button  on the screen and select "Power Off".
  - Press the power switch  on the dial for several seconds to turn it off.
3. Switch off the power from "I" position to "O" position.



4. Unplug the electricity from the outlet to avoid any unexpected injury to children or pets.



- **When the chair is still running, DO NOT walk directly outside of the chair and leave immediately.**  
Otherwise, it may cause accidents and injuries.



- **DO NOT step on the footrest after use when you get up.**  
Otherwise, the footrest may be damaged.
- **Make sure you have pressed the power switch to the OFF position and pulled out the power plug.**  
Otherwise, accidents and injuries may happen when children play with the chair.

# Care & Maintenance

## Storage Instructions

- When the chair is not in use, please ensure it is powered off and unplugged from the wall outlet to prevent accidents activation by children.
- If the chair is not to be used for an extended period, disconnect the controller and store the chair safely.
- Do not attempt to dismantle any part of the chair, including the chain hooks.
- Keep the massage chair free from dust by regularly wiping it down or covering it with a dust-free cloth.
- Avoid storing the chair in hot, humid, damp environments, or in direct sunlight or heat, as this may damage the chair.
- Similarly, do not store the chair in overly cold places, as extreme temperatures can adversely affect its performance and lifespan.

## Maintenance Instructions

- Before cleaning, ensure the chair is unplugged from the electric source to prevent electric shock.

### About Synthetic Leather

#### General Cleaning

- Clean with a tidy, soft, and dry cloth.
- Avoid using chemicals like thinners, gasoline, or alcohol.
- Before using any leather cleaner, ensure it is safe for the synthetic leather by reading the label.
- Before fully applying any cleaning solution, test it on a small section of the synthetic leather to avoid potential discoloration.



## About Plastic Parts

- Dip cloth into mild, neutral detergent, squeeze it, and clean the plastic parts.
- Avoid using chemicals like thinners, gasoline, or alcohol.
- Wipe with a damp microcloth, or a soft cloth wrung out in clean water. Ensure no water is dripping.
- Allow the plastic parts to dry naturally.



# FAQ/Important Notes

## Frequently Asked Questions(FAQ)

**Q** Can someone with a medical condition or disease use this product?

**A** **They must consult with their physicians before using the product.**

Massage can aggravate or worsen muscle injuries, bone disease, spinal abnormalities, skin disease and kill ones with medical devices implanted in their body.

**Q** Is there a restriction body height and weight to use this chair?

**A** **The recommended min. height is 4'9" with a max. height of 6'4". The max. weight capacity is 280 lbs.**

If the user is shorter or taller than the height range, they will not fit comfortably in the chair and may even experience injury. The maximum weight limit must be followed to avoid damaging the chair and also possibly seriously injuring yourself while using the device. The limits are in place for the user's safety.

**For a taller person with knee bending when using the product:**

Tilt the backrest and lower the Lower Leg/Foot massager to the down position, elongating the length from top to bottom.

**For a short person difficult to touch the foot massage section:**

Raise the backrest and raise the legrest to shorten the distance from the top to bottom.

**Q** Where is serial number of the product?

**A** **It is located at behind the backrest at the back of the chair by the power cord.**



**Q** When I use the chair it makes noise .

**A** **It is part of the normal function of the chair.**

The chair is equipped with an air pump and multiple motors. The sounds are part of chair when being operated.

**Q** How long should I use the massage chair each day?

**A** **20 minutes per day with no medical conditions.**

For the 1st week of using the chair, use only for 20 minutes at most assuming the user is in good medical condition. If there is any discomfort, stop using and consult with your doctor. In the first few days of using, you may experience mild soreness. Be sure to monitor the pain levels and if the soreness does not diminish after the following days, consult with your doctor before using again.

**BE SURE TO DRINK PLENTY OF WATER AFTER EACH MASSAGE.**

# Troubleshooting

**If an issue occurs, inspect, and trouble shoot according to the corresponding method below.**

If the problem is not solved, contact the manufacturer for further instructions, or service.

Fault	Cause and elimination method
<p><b>The massage wheels stop during use</b> (The product beeps and all icons and buttons on the remote controller flicker and then go out.)</p>	<p><b>As a safety protocol, the massage heads will stop if pressure/weight load has exceeded its limit.</b></p> <p>To avoid potentially over heating or damaging the massage mechanism, the chair is designed to automatically shut off if over strained or over heated. The remote will flash a few times and then shut off as a safety measure. If this has occurred, turn off the power switch from the back, allow for 30 sec, and power back on. If the weight capacity of 260 lbs is not exceeded, unplug from the outlet and notify the manufacturer.</p>
<p><b>The product cannot tilt, or the footrest cannot be raised, or lowered</b> (The product beeps, the running light on the remote controller goes out, and the product stops)</p>	<p><b>This product will stop upon any obstruction or a too large of a force preventing from operating.</b></p> <p>If all screen and buttons are flickering and the backrest or the footrest has stopped, turn off the power supply and turn back on 10 seconds. Be sure there are no obstructions in the way of the footrest or the backrest rolling mechanism.</p>
<p><b>The massage wheels cannot reach the shoulders or the neck</b></p>	<p>If your head is not properly placed against the backrest during the computer body scan, it may result in an incorrect reading, causing the rollers to start a lower position causing the massage to be inaccurate. If this occurs, turn off the power from the remote and start over again to get a proper reading.</p>
<p><b>The left and right massage wheels have different heights (intensities)</b></p>	<p>This is a normal function of the massage mechanism as it programmed to massage alternating locations from the right side during certain intervals of the program.</p>
<p><b>The chair is not functioning (massaging).</b></p> <ul style="list-style-type: none"> <li>● Upper body (the neck to the waist) massage</li> <li>● Lower leg/foot massage</li> </ul>	<ul style="list-style-type: none"> <li>● The power line is disconnected.</li> <li>● The power switch is not turned on.</li> <li>● If no program is selected after turning, the chair will pause and shut down. Turn off and restart.</li> </ul>
<p><b>The roller heads are still warm after turning off the heat or the product is damaged.</b></p>	<ul style="list-style-type: none"> <li>● Because the roller heads heat up it will take some time for the residual heat to dissipate.</li> <li>● If the massage heads are mildly warm, the rollers may be admitting heat created by the friction from the massage.</li> </ul>
<p><b>The power line or the power plug is abnormally warm to hot.</b></p>	<p>To avoid accidents, contact an authorized service center.</p>

If above solutions are not applicable, kindly refer to "Product Warranty Card" and contact service center.

## Troubleshooting (Continued)

### Expected sounds and feelings when using the massage chair.

**You will hear these specific sounds when using the product. These not defective indicators but a normal function of the chair.**

- When chair extends or retracts, you will hear gears moving and clicking.
- A rubbing sound will be mildly heard when the massage heads are activated.
- When the massage heads are tapping, you may hear a mild clicking sound.
- Friction sounds will be experienced as the rollers are activated.
- As the rollers move up and down, the motor produces a sound.
- As the rollers are activated, you will hear spinning of belts rotating.
- Motor sounds will be experienced.
- As the massage heads are squeezing, a mild squeaking sound will be heard.
- When sitting in the chair as the roller heads are tapping and rolling, a mild squeaking sound may be produced from the joints.
- Common joints that may squeak would be from the side panels.
- Friction sound between the massage wheels and the fabric.
- Motors will be heard from the pump when the airbags deflate.
- While the airbags are activated, you will hear air valves alternating. When the legrest is moving, you will hear a mild squeak and a motor operating.



**If the sound is loud, it is also possible that the product has failed.**

- In this case, have the product inspected and repaired by an authorized service center.

### **Warning**

- **Do not refit, disassemble, or repair the product without permission.** Otherwise fires, abnormal movements or personal injuries may happen.

### **Warning**

- **In the case of any abnormality or fault, stop the product immediately, and pull out the power plug to avoid fuming, fire and electric shock.**  
<Abnormality and fault example>
  - The product fails to work after the power switch is turned to the ON position;
  - When the power cable is moved, the chair will turn off and on.
  - In use, the product gives off a burning smell or an abnormal sound;  
The product upholstery is deformed or abnormally hot.If any of these symptoms occur, have the product inspected and repaired by an authorized service center immediately.

## Product Specifications

<b>Product Name</b>	Somnus 4D DuoFlex
<b>Rated Input</b>	110 - 120V~ 60Hz
<b>Rated Current</b>	2.5A
<b>Working Time</b>	Min. 4 minutes    Max. 30 minutes
<b>Extension of Footrest</b>	Approx. 7.1"
<b>Dimension (L x W x H)</b>	Upright: 65.0"x 31.5"x 47.2"
	Recline: 76.8"x 31.5"x 42.9"
<b>Dimensions of Packing (L*W*H)</b>	Box : 57.9"x 33.5"x 50.0"
<b>N.W.</b>	269.4 lbs
<b>G.W.</b>	315.7 lbs
<b>Weight of Chair</b>	Approx. 269.4 lbs
<b>Usage Condition</b>	Environment Temperature: 32°F - 104°F
	Contrasting Humidity: 20% - 80%RH
<b>Storage Condition</b>	Storage Temperature: 23°F - 95°F
	Storage Humidity: 20% - 80%RH
<b>Maximum Weight of User</b>	280 lbs
<p>This equipment contains a certified radio transmission module :            FCC ID: YMX-ATS2853            IC: 7284A-ATS2853</p>	

# FCC Radiation Exposure Statement

This equipment complies with FCC radiation exposure limits set forth for an uncontrolled environment. In order to avoid the possibility of exceeding the FCC radio frequency exposure limits, human proximity to the antenna shall not be less than 80mm(3.15") during normal operation.

## FCC STATEMENT

1. This device complies with Part 15 of the FCC Rules. Operation is subject to the following two conditions:
  - (1) This device may not cause harmful interference, and
  - (2) This device must accept any interference received, including interference that may cause undesired operation.
2. Changes or modifications not expressly approved by the party responsible for compliance could void the user's authority to operate the equipment.

This equipment has been tested and found to comply with the limits for a Class B digital device, pursuant to part 15 of the FCC Rules. These limits are designed to provide reasonable protection against harmful interference in a residential installation. This equipment generates, uses and can radiate radio frequency energy, and if not installed and used in accordance with the instructions, may cause harmful interference to radio communications. However, there is no guarantee that interference will not occur in a particular installation. If this equipment does cause harmful interference to radio or television reception, which can be determined by turning the equipment off and on, the user is encouraged to try to correct the interference by one or more of the following measures:

- Reorient or relocate the receiving antenna.
- Increase the separation between the equipment and receiver.
- Connect the equipment into an outlet on a separate circuit from the one connected to the receiver.
- Consult the dealer or an experienced radio/ TV technician for help.

## Industry Canada Notice

---

This device complies with Industry Canada licence-exempt RSS standard(s).

1. Operation is subject to the following two conditions:

- (1) this device may not cause interference, and
- (2) this device must accept any interference, including interference that may cause undesired operation of the device.

2. Changes or modifications not expressly approved by the party responsible for compliance,

### Avis d'Industrie Canada

Le présent appareil est conforme aux CNR d'Industrie Canada applicables aux appareils radio exempts de licence.

1. L'exploitation est autorisée aux deux conditions suivantes :

- (1) l'appareil ne doit pas produire de brouillage, et
- (2) l'utilisateur de l'appareil doit accepter tout brouillage radioélectrique subi, même si le brouillage est susceptible d'en compromettre le fonctionnement.

2. Cet appareil numérique ne dépasse pas les Rèlements sur l'interférence radio par un appareil numérique de classe B stipulées dans les Règlement sur l'interférence radio d'industrie Canada.





*Osaki*  
P L A T I N U M