

# Duke XL

## Service Manual



# Contents

I Product Component .....	3
1. Structure .....	1
2. Key Parts .....	3
II Common Faults and Troubleshooting Methods .....	5
1. Massage chair inoperable, remote controller no display .....	6
2. Massage mech、 Actuator not work、 Solenoid valve not work, remote controller on display .....	7
3. Abnormal lifting of mech .....	7
4. Abnormal kneading of mech .....	9
5. Abnormal tapping of mech .....	10
6. Abnormal tilting forward of mech .....	11
7. Whole unit/one air circuit not inflating .....	12
8. Back Actuator abnormal .....	13
9. Leg Actuator abnormal .....	14
10. Foot roller not work .....	15
11. Foot heating pad not work .....	15
12. Shawl heating pad not work .....	16
13. Bluetooth music abnormal .....	16
14. Charging abnormal .....	17
15. LED light strip abnormal .....	17
16. Health test abnormal .....	18

III. Mechanical Failures and Solutions .....	19
1. Replace massage mech .....	19
2. Remove armrest and shoulder assy .....	21
3. Remove legrest assy .....	28
4. Replace the circuit board, air pump and transformer of the whole chair .....	33
5. Replace Actuator .....	34
IV. Layout Diagram of Main Circuit Board Components .....	36
V. System Connection Diagram .....	37

# I. Product Component

## 1. Structure

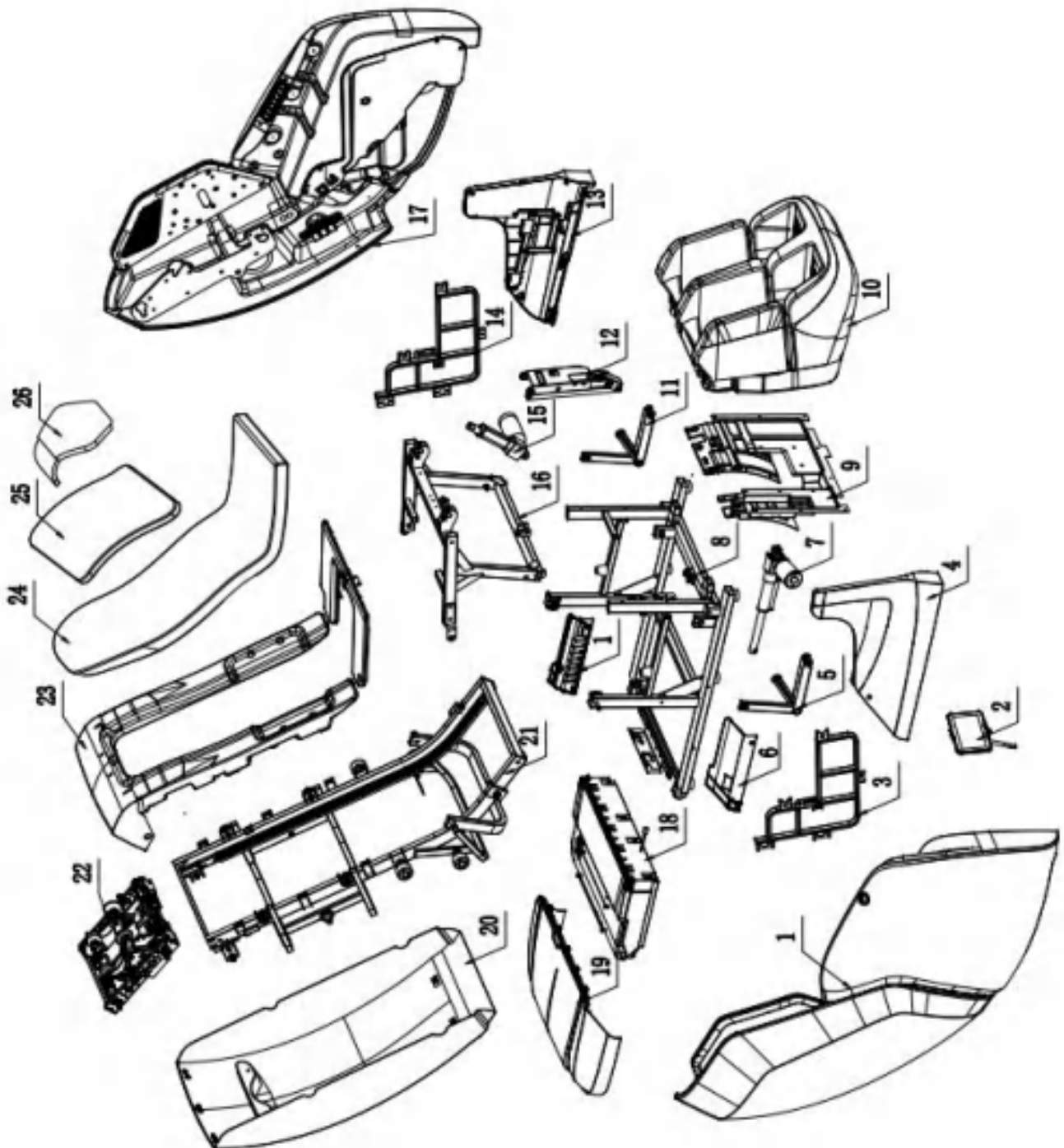

Mechanical Components List					
NO	NAME	PIECE	NO	NAME	PIECE
1	Right Arm & Shoulder Assembly	1	22	Massage Mech	1
2	CMC Tablet Controller	1	23	Front Cover Assembly	1
3	Armrest Conversion Rack Assembly (Right)	1	24	Back Seat Cushion	1
4	Right Fender	1	25	Shoulder Cushion	1
5	Rod Riveted Assembly (Right)	1	26	Pillow Assembly	1
6	Inner Fender (Right )	1			
7	Backrest Actuator	1			
8	Bottom Seat assembly	1			
9	Front Fender	1			
10	legrest Assembly	1			
11	Rod Riveted Assembly (Left)	1			
12	Leg &foot Connecting Plate Assembly	1			
13	Left Fender	1			
14	Left Armrest Transfer Frame	1			
15	Legrest Actuator	1			
16	Seat Frame Assembly	1			
17	Left Arm & Shoulder Assembly	1			
18	Power Box Assy	1			
19	Rear Cover Assembly	1			
20	Backrest Cover	1			
21	Backrest Frame Assembly	1			

## 2. Key Parts

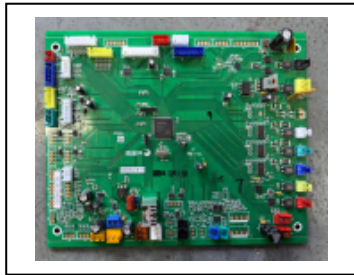

Main PCB

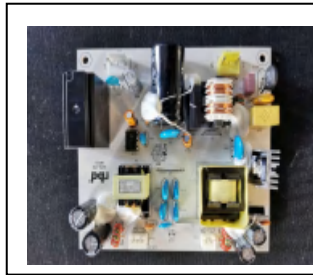

Power PCB

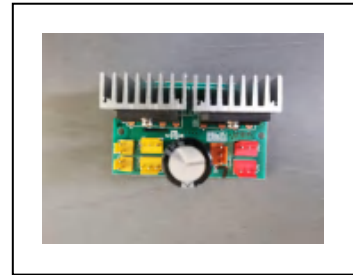

Rectifier Board

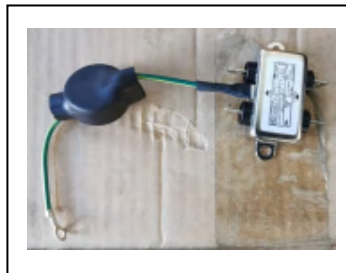

Filter

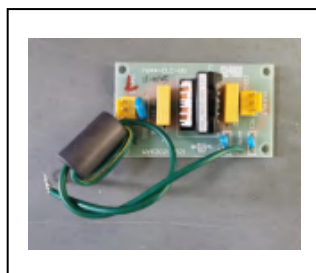

Filter Board

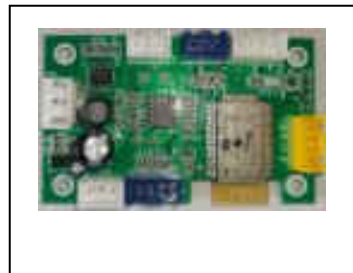

Bluetooth PCB

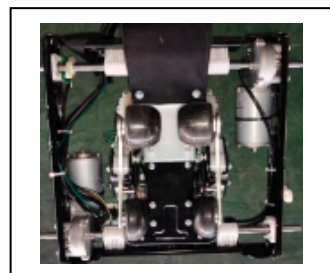

Massage mech



Leg Actuator



Back Actuator



Toroidal Transformer



Air pump

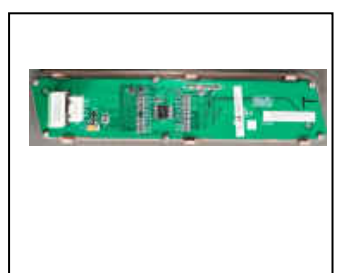

Quick button PCB



Health test module

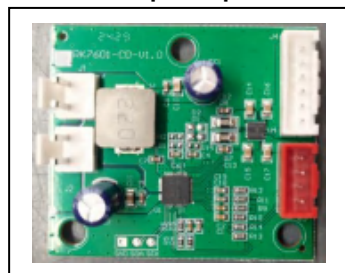

Charging board

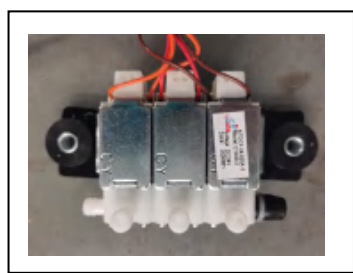

Three-way Solenoid Valve

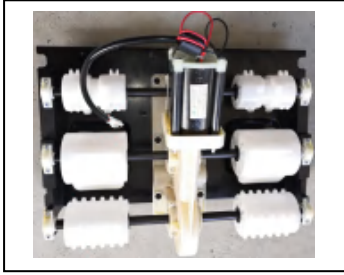

Roller Assembly

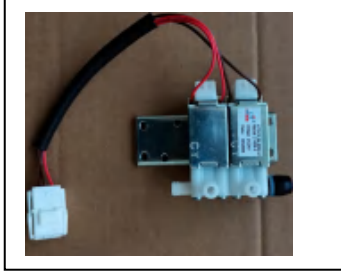

Two-way Solenoid Valve

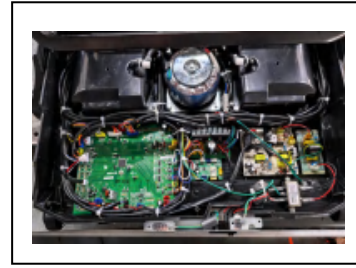

Power box



Speaker

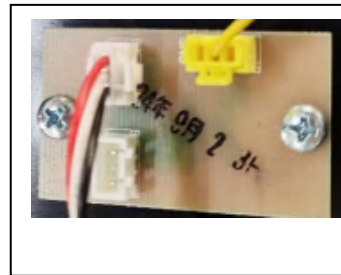

Anti-pinch Circuit Board Assembly

## II Common Faults and Troubleshooting Methods

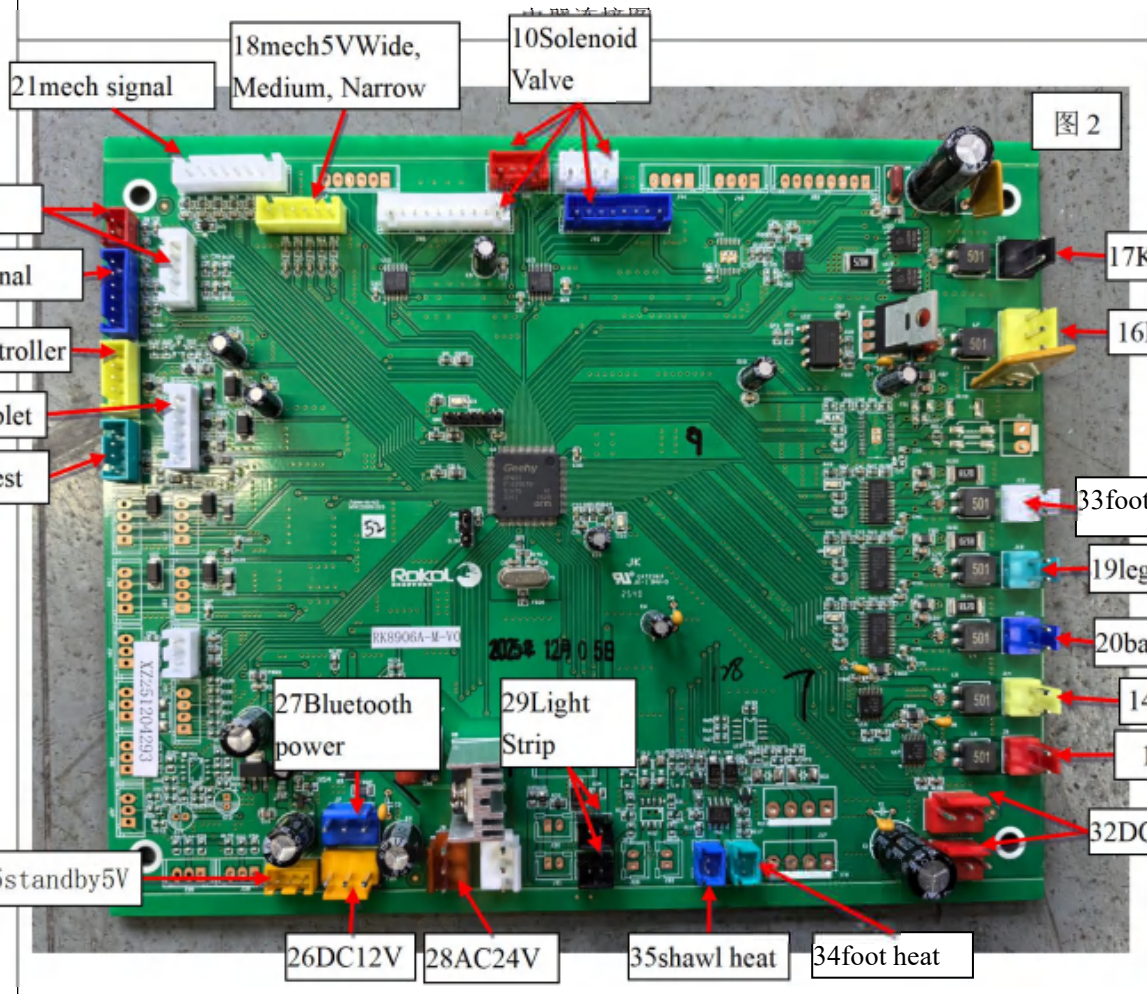
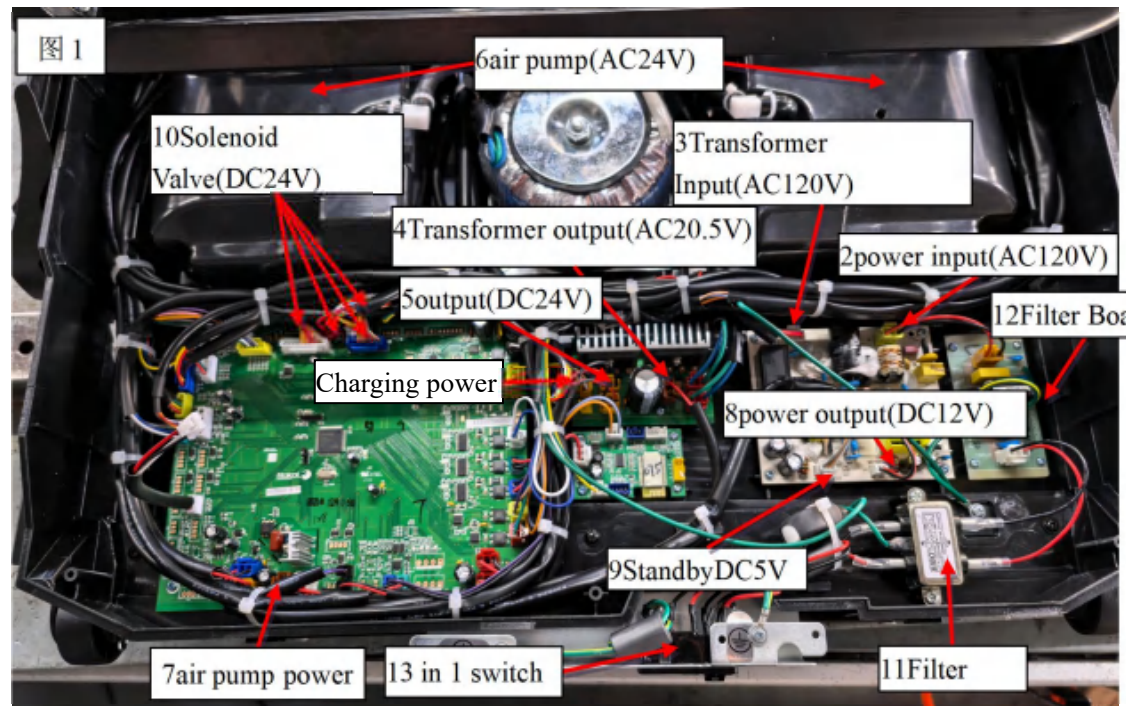

## **1. Massage chair inoperable, remote controller no display**

1.1 First check if the power outlet is live. Turn on the 3-in-1 switch on the switch base. Check if the fuse of the 3-in-1 switch (1 in Figure 1) is blown. If the fuse is burnt out, replace it to restore normal operation.

1.2 Use the multimeter AC voltage range to measure the voltage at the power input (2, AC120V). If the voltage is abnormal, check whether the filter (11) and filter board (12) are faulty, whether the wire harness is conductive, and whether the connectors are properly connected. If abnormal, replace the corresponding wire harness. Measure whether the input and output voltages are AC120V; if abnormal, replace the relevant part directly.

1.3 Use the multimeter DC voltage range to measure whether the voltage at the standby power & DC5V (25, DC5V) is normal. If there is no voltage, check whether the connecting wire between the power board and the mainboard is in good contact. If no problem is found, the power board is defective and should be replaced. If the 5V voltage is normal, power on and measure whether the standby voltage (white and orange wires) is at high level (DC5V). If it remains unchanged, the mainboard is defective and should be replaced.

1.4 Use the multimeter AC voltage range to measure the voltages

at the transformer input (3, AC120V) and transformer output (4, AC20.5V). If the voltage at 3 is normal but there is no voltage at 4, the toroidal transformer is defective and should be replaced. Otherwise, replace the power board.

1.5 Tablet no display. Use the multimeter DC voltage range to measure whether there is DC5V voltage at both ends of the mainboard CMC tablet connector (23). If yes, check whether the mating connector is securely connected and whether the wire harness is intact. If abnormal, replace the tablet hand control extension cable. Otherwise, replace the mainboard.

1.6 Simple hand controller no display and not working. Use the multimeter DC voltage range to measure whether there is DC5V voltage at both ends of the connector plugged into the simple hand controller. If yes, replace the simple hand control board assembly. Check the continuity of the wire harness and the connection of the connector between the simple hand controller and the mainboard (24). If abnormal, replace the corresponding wire harness assembly. Otherwise, replace the mainboard.

## **2. Massage mech、Actuator not work、Solenoid valve not work, remote controller on display**

2.1 Measure the voltage at the DC24V input of the mainboard (position 32) using the multimeter DC voltage range. If there is no

voltage, measure whether the rectifier board 5 output connector (3.96-3) has an output of approximately DC24V. If yes, replace the wiring harness between them.

2.2 If there is no voltage output, measure the transformer 4 output (AC20.5V) using the AC voltage range. If voltage is present, the rectifier board is faulty and should be replaced to restore normal operation.

2.3 Measure the voltages respectively using the multimeter DC voltage range at:

- Pin 4, Pin 5 and Pin 6 of the mainboard 23 CMC tablet;
- Pin 2, Pin 3 and Pin 4 of the mainboard 24 simple hand controller;
- Pin 2, Pin 3 and Pin 4 of the simple hand controller board.

If the voltage remains at a low level all the time or a short circuit is detected when power is off, the corresponding port is faulty.

Replace the circuit board to restore normal operation.

### **3.Abnormal lifting of mech**

3.1 When the massage chair is in up/down operation mode but the lifting mechanism does not actuate:

3.1.1 Activate the full travel command for the massage chair via manual control on the tablet hand controller. Use the multimeter DC voltage range to measure whether there is voltage output (approximately DC24V) at connector 13 on the mainboard (Figure

2). If no voltage is present, the mainboard is faulty and should be replaced to restore normal operation.

3.1.2 If the voltage is normal, unplug the connector and use the multimeter buzzer range to check the continuity of the blue and green wires between the mainboard and the black 3-pin 450B connector of the lifting motor. Also inspect whether the mating connectors are securely fastened, whether terminals are loose or properly contacted. If continuity is normal, the lifting motor is defective and the lifting motor or movement assembly needs to be replaced. If either wire shows an open circuit, replace the corresponding motor mating wiring harness assembly of the massage chair.

3.1.3 To determine whether the lifting motor is damaged, set the multimeter to the resistance range and measure the resistance at both ends of the lifting motor connector. The normal resistance should be 5–30Ω. If there is no reading or the resistance is excessively high, the motor is damaged.

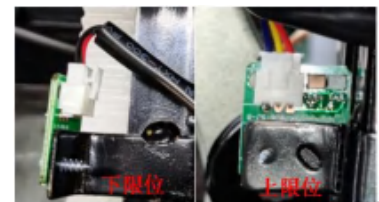

3.2 When the massage chair is operating in the up/down mode and exhibits overtravel (hitting the top or bottom limit beyond the normal position), this indicates a fault in the up/down limit signal of the lifting motor.

3.2.1 Check whether the connector at the lifting limit position 22 on the mainboard (Figure 2) to the connector on the up/down limit board has come loose, and whether the connector terminals are disengaged, as shown in the figure above.

3.2.2 Measure whether there is DC5V at both ends of the connector shown in the right figure. If normal, check whether the lifting limit Hall element has a high/low level change (bring a magnet close to or away from the Hall element, and measure pins 2 and 3 of the upper limit or lower limit connector). If there is no level change on pins 2 and 3, replace the lifting limit board.

3.2.3 Unplug the connector at position 22 in Figure 2. Use the multimeter buzzer mode to check the continuity of the wiring harness between the mainboard and the up/down limit board. If all connections are normal, the mainboard is faulty and should be replaced. If there is an open circuit, replace the lifting limit wiring harness.

3.3 If the massage chair cannot operate in a specific zone such as the shoulder-back or waist-back area but runs the full stroke, this indicates a signal fault at the lifting counting position 21 on the mainboard shown in Figure 2.

3.3.1 First use the multimeter DC voltage range to measure the wiring harness from the mainboard to the movement adapter board. The DC12V voltage between the red and black wires should be normal. Slowly rotate the lifting motor shaft by hand and check whether there is a high/low voltage change between pin 1 (brown wire) and pin 8 of the mainboard connector 21. If voltage changes occur, replace the mainboard.

3.3.2 If there is no voltage change, unplug the connector and use the multimeter buzzer mode to check the continuity of the wiring harness between the brown wire on the mainboard and the movement adapter board, as well as the continuity between the adapter board and the lifting motor. Also check whether the connectors



are securely connected and whether terminals are disengaged. If abnormal, replace the corresponding wiring harness assembly.

3.3.3 Check the continuity of the red and black counting wires between the adapter board and the lifting motor. If abnormal, replace them. Otherwise, replace the lifting motor encoder assembly.

3.4 After power-on and entering a program, the massage chair starts shoulder height detection.

If the massage chair stops directly at the upper limit or on the back, it indicates a shoulder height detection fault, as shown in the figure on the right.

3.4.1 Use the multimeter DC voltage range to measure the voltage between pins 2 and 4 of the yellow connector on the adapter board. Press and release the rocker arm (equipped with detection components) by hand and check whether there is a high/low level change in the measured voltage. If there is no level change, replace the shoulder detection wiring harness assembly.

3.4.2 Unplug the mainboard 21 movement signal connector. Use the multimeter buzzer range to check continuity between the yellow shoulder detection wire at pin 2 of mainboard 21 and the green wire of the shoulder detection harness. Also check whether the connector is securely connected and whether terminals are disengaged. If abnormal, replace the corresponding harness. Otherwise, replace the mainboard.

#### **4.Abnormal kneading of mech**

4.1 No kneading action of the massage mechanism.

4.1.1 Activate the kneading command via manual control on the tablet. Use the multimeter DC voltage range to measure whether there is approximately DC9–20V voltage output at the terminals of

the kneading motor connector 17 on the mainboard. If no voltage is output, the mainboard is faulty and should be replaced.

4.1.2 If voltage is present, check whether the mating connector of the wiring harness between position 17 and the kneading motor is securely connected, and whether the terminals are properly engaged with good contact. If normal, unplug the connector and use the multimeter buzzer range to check the continuity of the white and black wires from mainboard connector 17 to both ends of the black 2-pin 396 connector on the adapter board. If all connections are normal, the kneading motor is defective, and the kneading motor or movement assembly needs to be replaced. If there is an open circuit, replace the motor wiring harness assembly of the massage chair. The method for judging whether the kneading motor is damaged is the same as that for the lifting motor in 3.1.3.

4.2 The kneading function operates immediately when the massage chair is powered on and cannot be turned off via tablet operation. This indicates the mainboard is faulty and should be replaced.

## **5.Abnormal tapping of mech**

5.1 No tapping action of the massage mechanism.

5.1.1 Activate the tapping command via manual control on the tablet. Use the multimeter DC voltage range to measure whether

there is approximately DC9–20V voltage output at both ends of the tapping motor connector 16 on the mainboard. If no voltage is present, the mainboard is faulty and should be replaced to restore normal operation.

5.1.2 If the voltage from the mainboard is normal, check whether the mating connector between the mainboard and the tapping motor is securely connected, and whether the terminals are disengaged or in good contact. If normal, unplug the connector and use the multimeter buzzer range to check the continuity of the yellow and red wires from mainboard connector 16 to the yellow 2-pin 396 connector on the adapter board. If all connections are normal, the tapping motor is defective, and the tapping motor or movement assembly needs to be replaced. If either wire is open, replace the motor wiring harness assembly of the massage chair. The method for judging whether the tapping motor is damaged is the same as that for the lifting motor in 3.1.3.

5.2 The tapping function operates immediately when the massage chair is powered on and cannot be turned off via tablet operation.

This indicates the mainboard is faulty and should be replaced.

5.3 When the tablet is activated to tapping mode, if the wide/medium/narrow width

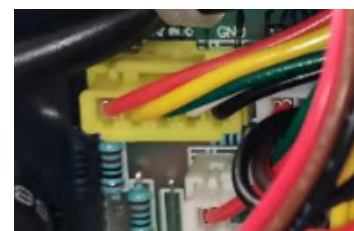

cannot be selected or is incorrect, the movement width signal is faulty, as shown in the right figure.

5.3.1 Use the multimeter DC voltage range to measure whether there is high/low voltage change between the yellow, green, white wires and the black wire of the yellow 5-pin connector on the adapter board. If no change occurs, the kneading encoder assembly is faulty; replace the encoder assembly or the movement.

5.3.2 Unplug the width connector at position 18 on the mainboard. Use the multimeter buzzer range to check the continuity of the green, white and blue wires to the adapter board harness, whether the connectors are securely connected, and whether the terminals are disengaged. If abnormal, replace the corresponding massage chair signal harness. Otherwise, replace the mainboard.

## **6.Abnormal tilting forward of mech**

6.1 No forward tilting action of the massage mechanism. Activate the forward tilt command via manual control on the tablet.

6.1.1 Set the multimeter to the DC voltage range and measure whether the voltage output at both ends of the forward tilt motor connector 14 on the mainboard is normal. If there is no voltage output, the mainboard is faulty and should be replaced to restore normal operation.

6.1.2 If the voltage is normal, check whether the mating connector between the mainboard and the forward tilt motor is securely fastened and whether the terminals are in good contact. Then use the multimeter buzzer range to check the continuity of the brown and purple wires from mainboard connector 14 to the black 3-pin 450B mating connector of the forward tilt motor harness. If all connections are normal, the forward tilt motor is defective and needs to be replaced, or the movement assembly should be replaced. If there is an open circuit, replace the corresponding motor wiring harness assembly of the massage chair. The method for judging whether the forward tilt motor is damaged is the same as that for the lifting motor in 3.1.3.

6.2 The massage mechanism fails to reach the full forward tilt position, indicating a forward tilt counting fault.

6.2.1 Slowly rotate the forward tilt motor shaft by hand. Use the multimeter DC voltage range to measure whether there is a high/low voltage change between pin 3 (pink wire) and pin 8 of mainboard connector 21. If voltage changes occur, replace the mainboard.

6.2.2 If there is no voltage change, unplug the connector and use the multimeter buzzer range to check the continuity of the wiring harness between the pink wire on the mainboard and the

movement adapter board, whether the connectors are securely connected, and whether the terminals are disengaged. If abnormal, replace the corresponding signal wiring harness assembly of the massage chair. Otherwise, replace the lifting motor encoder.

6.3 Forward tilt overtravel (hitting the top or bottom limit).

6.3.1 Set the multimeter to the DC voltage range. Bring a magnet close to or away from the Hall element and measure whether the voltage output between pins 4, 5 and pin 8 of the mainboard 21 movement signal connector is normal. If voltage is present, the mainboard is faulty and should be replaced to restore normal operation.

6.3.2 If there is no voltage, check the continuity of the wiring harness between the orange wire (pin 4) and purple wire (pin 5) of mainboard connector 21 to the adapter board, as well as the harness between the adapter board and the forward tilt limit board. Also check whether the connectors are securely connected and whether the terminals are disengaged. If abnormal, replace the corresponding signal wiring harness assembly or 3D limit wiring harness assembly of the massage chair. Otherwise, replace the 3D limit board assembly.

## **7. Whole unit/one air circuit not inflating**

7.1 If the whole chair has no inflation, measure the voltage at

connector 7 on the mainboard using the multimeter AC voltage range after power-on. If there is approximately AC24V, check for loose connectors and continuity issues in the wiring harness. If normal, the air pump is defective and should be replaced. If there is no voltage output but the voltage at AC24V (position 28) is normal, the mainboard is faulty and should be replaced.

7.2 Check if the air hoses are loose, blocked, kinked, poorly connected, or damaged and leaking.

7.3 If one specific air channel fails to inflate:

7.3.1 Use the multimeter DC voltage range to measure whether the corresponding port has DC24V voltage output. If no output, the corresponding mainboard circuit is faulty and should be replaced.

7.3.2 Alternatively, turn off the power and use the multimeter buzzer range to check for abnormal continuity in the wiring harness between the mainboard and the solenoid valve, and whether connectors are securely fastened. Replace if abnormal. Use the multimeter ohm range to measure the resistance of the corresponding solenoid valve (normal resistance:  $210\Omega \pm 10\%$ ). If there is no resistance, or the resistance is too high or too low, the solenoid valve is defective and should be replaced.

7.3.3 Check the air hose between the solenoid valve and the airbag for kinking, disconnection, or damage.

7.4 If inflation is weak, check for blockage, air leakage, or damage in the air hoses, solenoid valves, and airbags.

7.5 For non-functioning leg and foot solenoid valves, in addition to checking DC24V and output, also check the continuity of the wiring harness between the leg and foot solenoid valve serial port (position 10) on the mainboard and the sole solenoid valve serial port, whether connectors are securely fastened, and whether terminals are disengaged. Replace the corresponding harness if abnormal. Check the mating harness to the solenoid valve and replace if abnormal.

The corresponding ports of the solenoid valves are as follows:



NO.	Circuit Board Ports Corresponding to Solenoid Valves
1	Left front Arm
2	Left rear Arm
3	Left shoulder
4	Right front Arm
5	Right rear Arm
6	Right shoulder
7	Front Foot
8	Rear foot
9	Rear leg

---

10	Leg Side
----	----------

## 8. Back Actuator abnormal

8.1 Electric Back Actuator does not operate.

8.1.1 Set the multimeter to DC voltage range, insert the two probes into the blue connector terminals at the Back Actuator (position 20). Operate the backrest up/down buttons on the tablet hand controller and observe whether the multimeter shows DC24V output. If no voltage is present, the mainboard is faulty and should be replaced.

8.1.2 Check whether the wiring harness between position 20 and the actuator connector is securely connected and whether terminals are disengaged. Check harness continuity; replace the corresponding harness assembly if open-circuited. Unplug the actuator connector and measure the resistance between the two wires of the actuator. If the actuator is at the upper or lower limit, use the diode range to test in both directions; one-way conduction means it is good. At other positions, 3–20 $\Omega$  is normal. Otherwise, the electric actuator motor is defective and should be replaced.

8.2 Electric Back Actuator cannot stop at the initial massage position.

8.2.1 Set the multimeter to DC voltage range, place the two probes between the green and gray wires of the connector at the actuator counting signal (position 31). Operate the backrest up/down

buttons on the tablet hand controller and observe whether the multimeter shows high/low level output. If level changes exist, the mainboard is faulty and should be replaced.

8.2.2 Check the continuity of the wiring harness to the actuator and whether connectors are securely connected. If normal, the actuator is defective and should be replaced. Otherwise, replace the corresponding harness assembly.

## **9. Leg Actuator abnormal**

9.1 Leg Actuator does not operate.

9.1.1 Set the multimeter to DC voltage range, insert the two probes into the green connector terminals at the Leg Actuator (position 19). Operate the backrest up/down or leg lift buttons on the tablet hand controller and observe whether the multimeter shows DC24V output. If no voltage is present, the mainboard is faulty and should be replaced.

9.1.2 Check whether the wiring harness between position 19 and the actuator connector is securely connected and whether terminals are disengaged. Check harness continuity; replace the corresponding harness assembly if open-circuited. Unplug the actuator connector and measure the resistance between the two wires of the actuator. If the actuator is at the upper or lower limit, use the diode range to test in both directions; one-way conduction

means it is good. At other positions, 3–20 $\Omega$  is normal. Otherwise, the electric actuator motor is defective and should be replaced.

9.2 Leg Actuator cannot stop at the initial massage position.

9.2.1 Set the multimeter to DC voltage range, place the two probes between the yellow and black wires of the connector at the actuator counting signal (position 31). Operate the backrest up/down buttons on the tablet hand controller and observe whether the multimeter shows high/low level output. If level changes exist, the mainboard is faulty and should be replaced.

9.2.2 Check the continuity of the wiring harness to the actuator and whether connectors are securely connected. If normal, the actuator is defective and should be replaced. Otherwise, replace the corresponding harness assembly.

Actuator Swap Test:

If the circuit board shows no obvious burning damage, swap the power supply and signal wires (yellow, green) of the leg actuator and back actuator at the same time. Connect the faulty actuator to the circuit of the normal actuator and operate the normal actuator function. If the actuator works properly, the circuit board is faulty. Otherwise, the electric actuator is defective and should be replaced.

**10. Foot roller not work**

10.1 Turn on the foot roller function (leg and foot air pressure), but it does not work. Use the multimeter DC voltage range to measure whether there is DC24V at the foot roller (DC24) connector in Figure 1. If abnormal, check the connector mating and harness continuity between the connector and the mainboard. Replace the mating harness if abnormal.

10.2 Set the multimeter to DC voltage range, insert the two probes into the terminals of the foot roller (DC24) connector in Figure 1, and check whether the output voltage is normal. If no voltage is present, the mainboard is faulty. If there is voltage output, use the multimeter to measure the voltage between the red and black wires at the other end of the harness (450 connector) of the foot roller motor. If no voltage is present, replace this harness assembly; otherwise, the roller motor is faulty and should be replaced.

## **11.Foot Heating Pad Not Work**

11.1 Turn on the foot heating function on the tablet. First refer to step 10.1 to check for issues in the wiring harness to the mainboard. Check whether the connectors to the heating pad are securely connected and whether any terminals are disengaged.

11.2 Measure whether the voltage at the foot heating position 34 in Figure 1 is DC24V. If there is no voltage output, the mainboard is faulty. If voltage is present, use a multimeter to check whether the

heating wire connector has DC24V. If not, replace the heating wire. If voltage is present, replace the heating pad.

## 12.Shawl Heating Pad Not Work

12.1 Turn on the shoulder heating function on the tablet. Check whether the connectors to the heating pad are securely connected and whether any terminals are disengaged.

12.2 Measure whether the voltage at the shoulder heating position 35 on the mainboard is DC24V. If there is no voltage output, the mainboard is faulty. If voltage is present, use a multimeter to check whether the DC connector of the heating wire has DC24V. If not, replace the heating wire. If voltage is present, replace the heating pad.

## 13.13. Bluetooth music abnormal

13.1 Speaker not working. Measure the voltage at mainboard connector 27 to check if it is DC12V. If there is no voltage output, the mainboard is faulty.

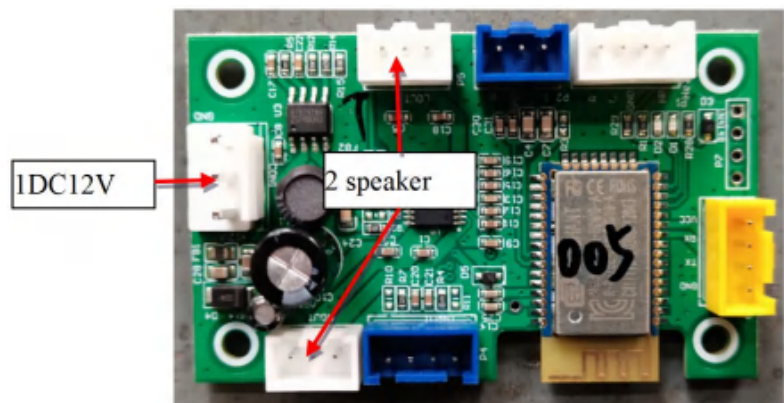

13.2 Check whether the Bluetooth board 1DC12VCON1 has DC12V voltage. If not, check whether the mating connector is

securely connected and whether the wiring harness continuity is normal; replace the corresponding harness if abnormal. If voltage is present and the Bluetooth board LED is on, connect the phone to Bluetooth and play music. If connection fails, replace the Bluetooth board.

13.3 Use the multimeter in AC mode to measure whether there is fluctuating voltage output at the left and right speakers LOUT and ROUT on the amplifier board 2. If not, replace the voice board. If voltage is present, check the continuity of the wiring harness to the left and right speakers, then replace the speakers if no issues are found.

## 14. Charging abnormal

14.1 USB charging abnormality. No charging when mobile phone is connected.

14.1.1 Use the multimeter in DC range to measure whether there is voltage output at the mainboard 5 output (DC24V) charging power supply. If no voltage, replace the rectifier board.

14.1.2 Unplug the connector and use the multimeter in buzzer range to check the continuity of the wiring harness between the rectifier board and the left armrest charging board, and between the charging board and the Type-C circuit board. Check whether the

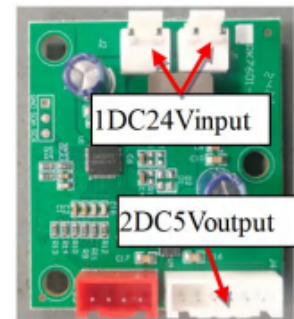

connectors are properly connected and whether the terminals are disengaged. If abnormal, replace the corresponding wiring harness assembly.

14.1.3 Use the multimeter in DC range to measure whether there is voltage output between each port of the charging board 2 DC5V output and pin 6. If no voltage, replace the charging board. Otherwise, replace the Type-C circuit board.

## 15.2 LED light strip abnormal

15.2.1 Use the multimeter in buzzer mode to check the continuity of the wiring harness between the mainboard 29 light strip harness and the left & right armrests, whether the connectors are securely connected, and whether the terminals are disengaged. If abnormal, replace the corresponding harness assembly.

15.2.2 Power on the unit. Use the multimeter in DC voltage mode to measure whether there is DC12V voltage at both ends of the 12LED light strip connector on the left and right armrest circuit boards. If no voltage is present, replace the armrest circuit board.

15.2.3 Use the multimeter in DC voltage mode to measure whether there is DC12V at both ends of the mating connector. If voltage is present, replace the LED light strip assembly.

## 16. Health test abnormal

16.1 Turn on the health test function on the tablet after power-on; if it fails to detect, check whether the contact surface of the health test module is heavily dirty or obstructed. If so, clean it.

16.2 Check whether the wiring harness and connectors between the tablet hand controller cable and the health test module on the right armrest are securely connected, whether the terminals are disengaged, and whether the harness continuity is normal. Reconnect if loose. Replace the corresponding harness assembly if continuity is abnormal.

16.3 Use the multimeter in DC voltage mode to measure whether there is voltage output (DC5V) between the white and purple wires at the health test port 36 on the mainboard. If no voltage output, replace the mainboard. Otherwise, replace the health test module.

### III. Mechanical Failures and Solutions

#### 1. Replace massage mech

1.1 Remove the Rear Shield: As shown in the figure, use a Phillips screwdriver to remove the 2 ST4.2×16 assembly screws. Then firmly release the 3 snap ball heads on the upper part of the rear shield, lift the rear shield upward, and the backrest rear shield can be removed.

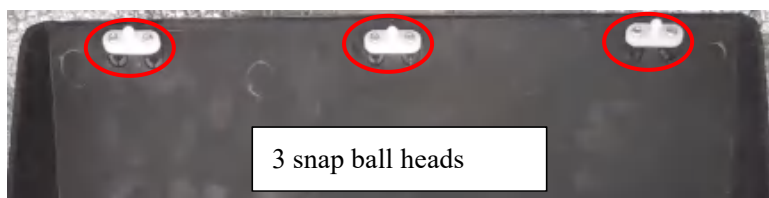
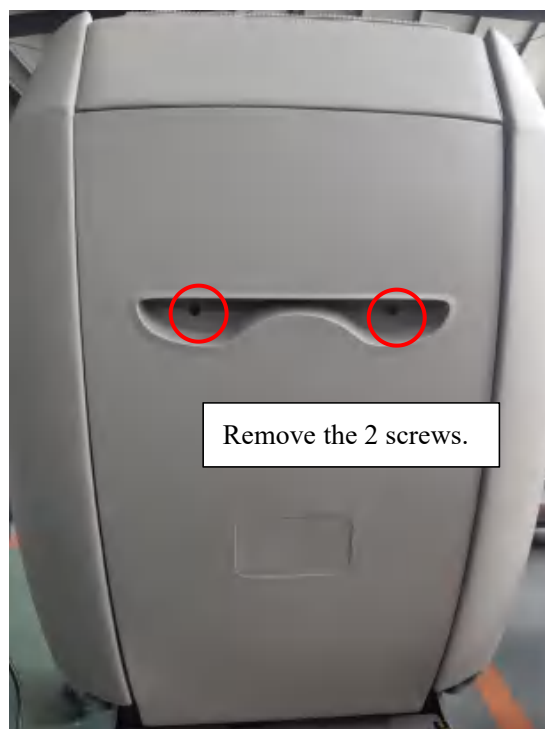

Diagram of the Inner Upper Part of the Rear Shield

When installing the rear shield, engage the 3 snap ball heads into the 3 snap ball sockets on the backrest.  
When removing the rear shield, disengage the 3 snap ball heads.

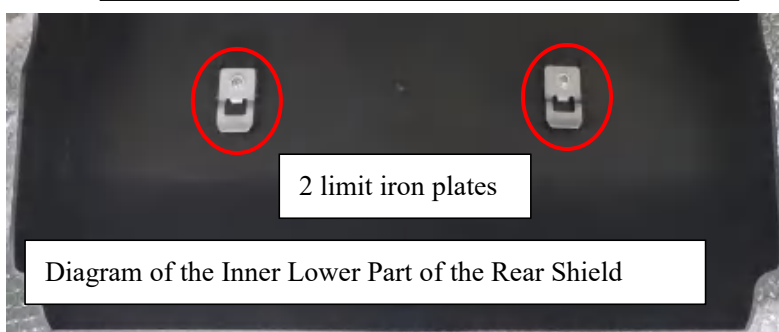

Diagram of the Inner Lower Part of the Rear Shield

When installing the rear shield, secure the 2 limit iron plates onto the lower bent pipe of the backrest.  
When removing the rear shield, lift the rear shield upward to release the limit iron plates from the lower bent pipe of the backrest.

1.2 Remove the Upper Backrest Bent Pipe: Remove the screw M6×35, nut M6 and flat washer that secure the upper backrest bent pipe, then the pipe can be taken off.

1.3 Remove the Guide Rail Connectors: Remove the 3 screws ST4×10 for each of the left and right guide rail connectors, then the connectors can be taken off.

1.4 Remove the Massage Mech: Raise the massage mech to the upper end of the backrest. Unplug the 2 connectors on the massage mech wiring harness at the lower left side of the backrest, and remove the screw ST4×10 that secures the ground wire. The massage mech can then be taken off for replacement.

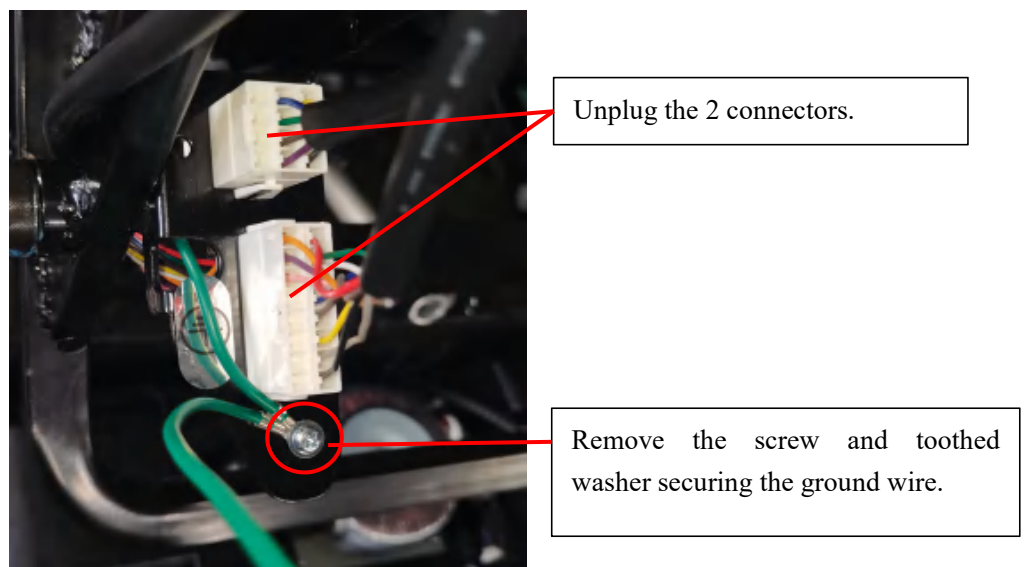

Note: When installing the massage mech, the tooth crests and tooth roots of the lifting gears on both left and right sides must be fully symmetrical, with crest to crest and root to root.

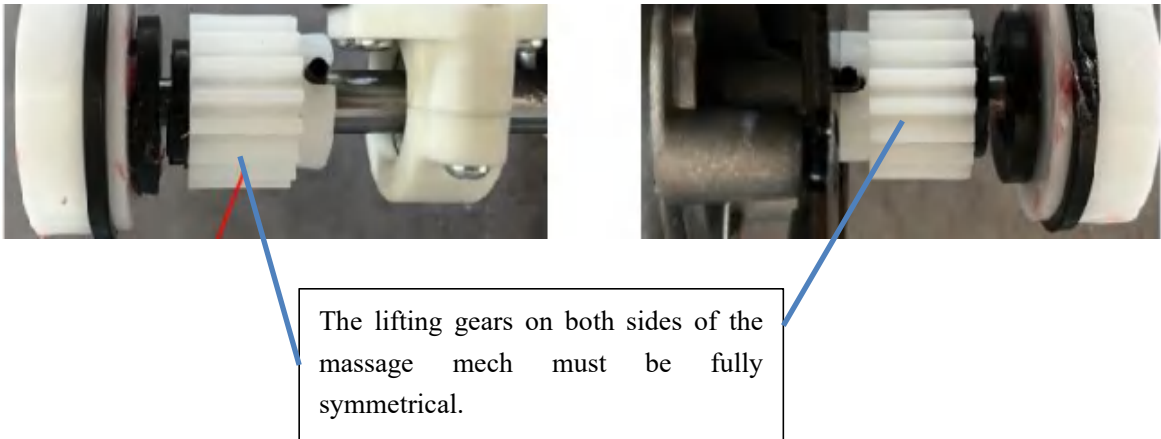

## 2.Remove armrest and shoulder assy

### 2.1 Replace Armrest Shoulder Assembly

2.1.1 Remove Armrest Interior Panel: Adjust the massage chair to zero-gravity mode. Remove the screw ST3.9×12.7 securing the armrest interior panel. Release the 3 ball sockets of the armrest interior panel firmly, then lift the armrest interior panel upward to remove it.

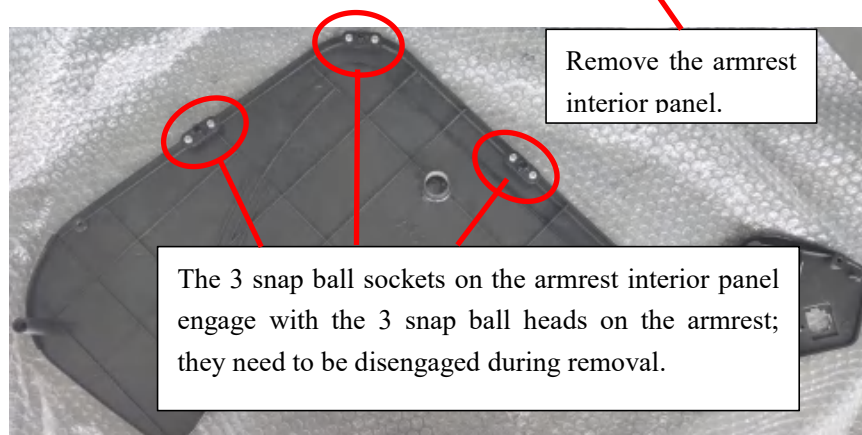

2.1.2 Replace Armrest Shoulder Assembly: Unplug the air tube and connector. Use a hex wrench to remove the mounting screw M6×16 and flat washer. Lift the armrest upward, then the armrest shoulder assembly can be removed from the side.

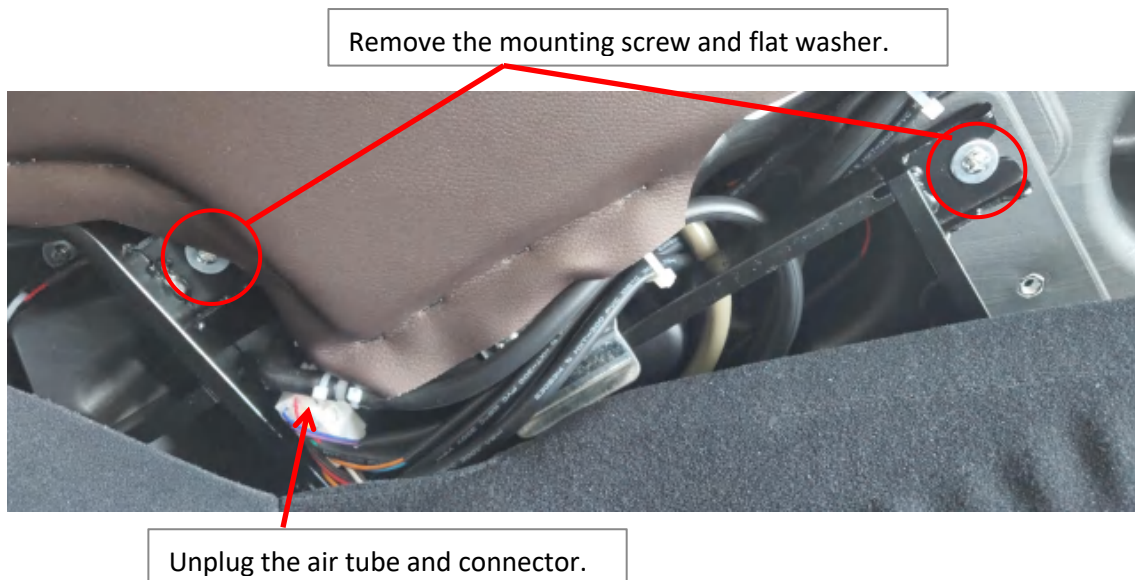

2.2 Replace the solenoid valve of the armrest shoulder.

First remove the armrest shoulder assembly according to 2.1.1 and 2.1.2.

2.2.1 Unplug the air tubes connected to the solenoid valve (first remove the cable ties binding the air tubes). The purple air tube is for the shoulder airbag, the brown one for the rear armrest airbag, and the black one for the front armrest airbag. Then remove the cable ties binding the solenoid valve wiring harness and unplug the connector of the solenoid valve harness. Remove 2 pieces of screws ST4.8×25 and flat washers. Then remove the 4 screws

ST3×10 fixing the solenoid valve for replacement.

### 2.3 Replace the 18W Fast Charging Module

First remove the armrest shoulder assembly according to 2.1.1 and 2.1.2.

Unplug the wiring harness connected to the 18W fast charging module and remove the 3 fixing screws ST3.9×9.5 for replacement.

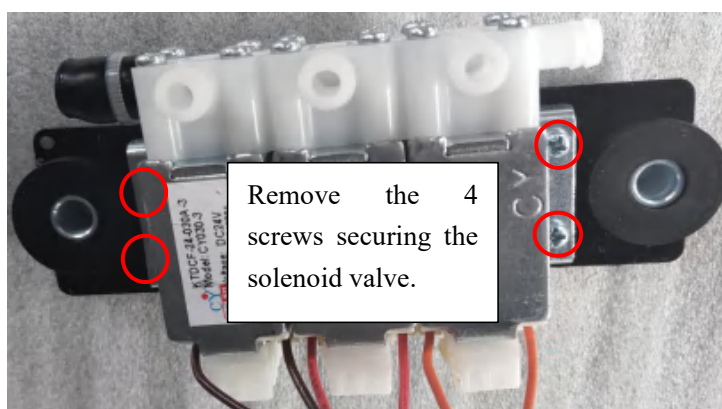
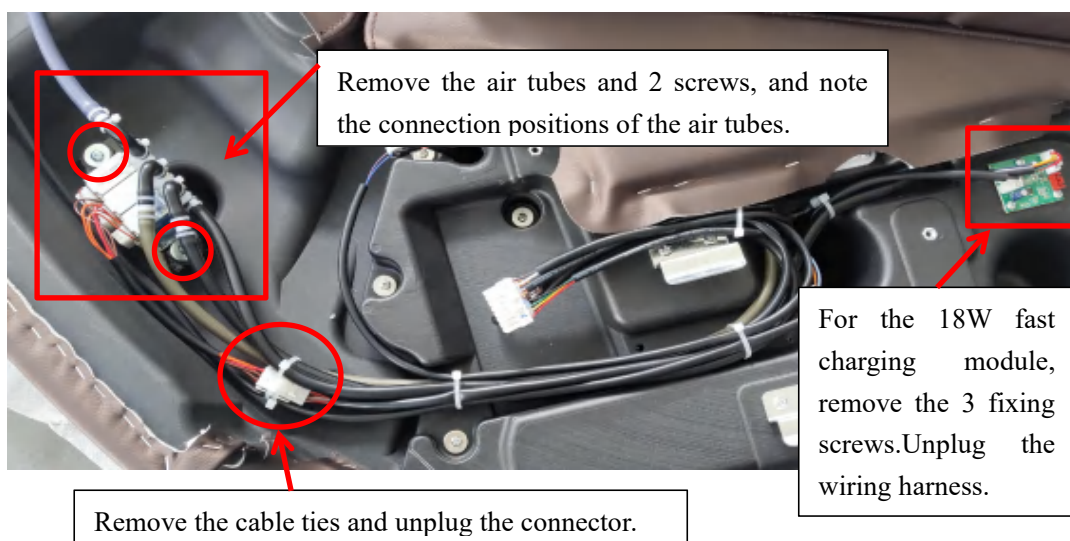

2.4 Replace the simple controller of the left armrest: Pry up the

simple controller from the two long sides, unplug the 2 connectors, then the simple controller can be replaced. The simple controller and the armrest plastic body adopt a buckle structure.

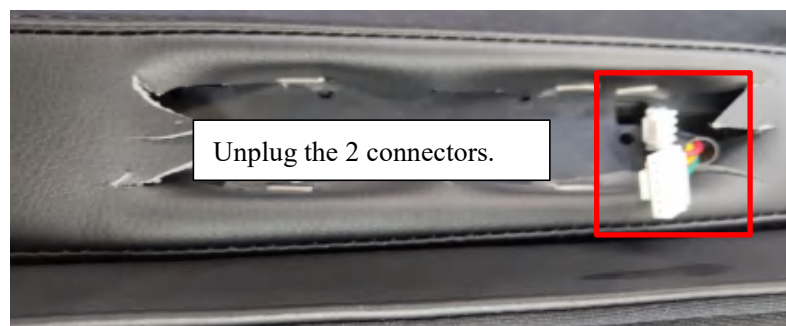
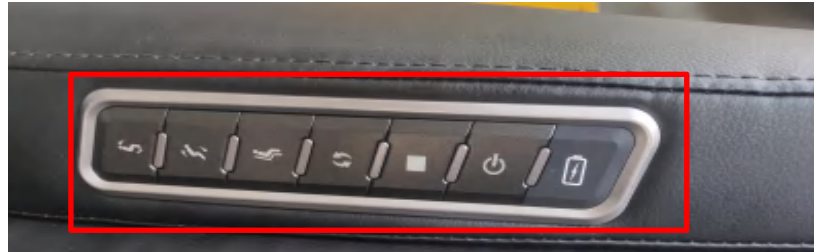

2.5 Replace the shoulder airbag: Unzip the zipper of the shoulder airbag assembly to expose the airbag. Remove the 3 ST3.9×12.7 combination screws and flat washers securing the airbag, then unplug the air tube of the shoulder airbag for replacement.



Unzip the zipper.



Remove the 3 screws securing the airbag.



Remove the cable ties and unplug the air tube on the airbag.

## 2.6 Replace the shoulder speaker

Remove the shoulder airbag following the steps in 2.5.

2.6.1 Remove the 5 ST3.9×12.7 combination screws securing the airbag support plate, take off the airbag support plate, and remove the sewing assembly.



Airbag support plate, remove the 5 screws.

2.6.2 Remove the speaker grille. The speaker grille is installed with a buckle structure; pry it off.



Speaker Grille

2.6.3 Remove the speaker inner housing. Remove the 12 screws ST3.9\*9.5 securing the speaker inner housing, remove the cable ties binding the speaker wiring harness, and unplug the connector to remove the speaker inner housing.

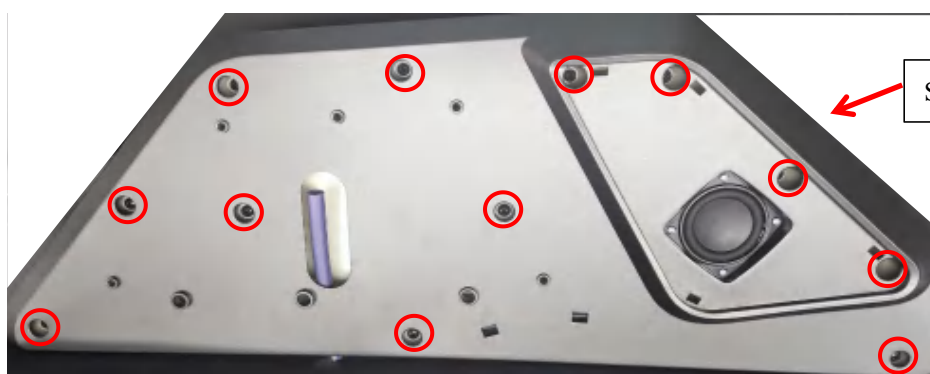

Speaker Inner Housing

2.6.4 Replace the speaker. Remove the 4 screws ST3×10 securing the speaker, then the speaker can be replaced. Pay attention to the position of the speaker wiring harness.

2.7 Replace the arm airbag: Unzip the arm airbag assembly zipper, remove the 4 screws securing the airbag, remove the cable ties holding the air tube, unplug the air tube, then take the airbag out of the assembly for replacement.

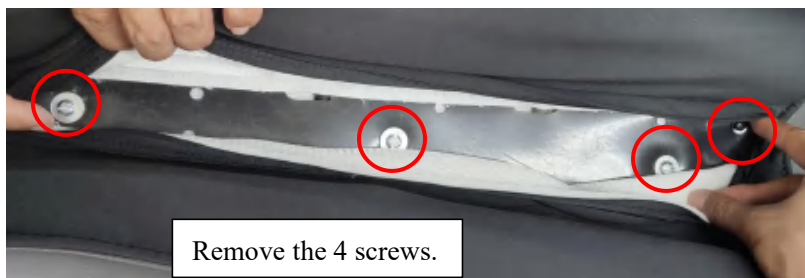

Remove the cable ties in the circled area as shown in the diagram and unplug the air tube.

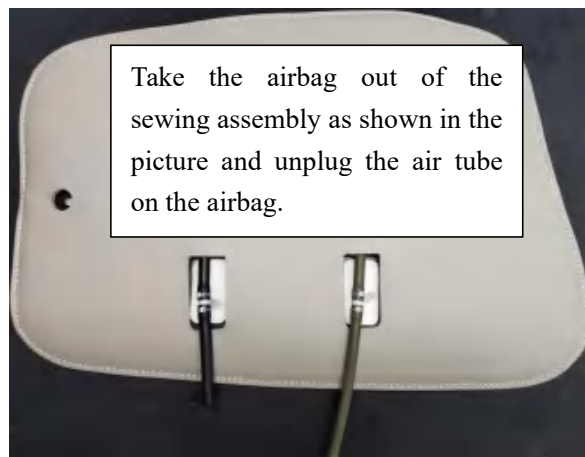

Arm Airbag →



## 2.8 Replace the Armrest Light Strip

First remove the armrest and shoulder assembly according to 2.1.1 and 2.1.2.

2.8.1 Replace the armrest light strip: First remove the 5 screws M5×25 and large flat washers connecting the armrest and shoulder, remove the cable ties binding the light strip wiring harness, and unplug the connector.

Remove the 4 screws ST3.9×12.7 fixing the lampshade to expose the light strip, then the light strip can be replaced.

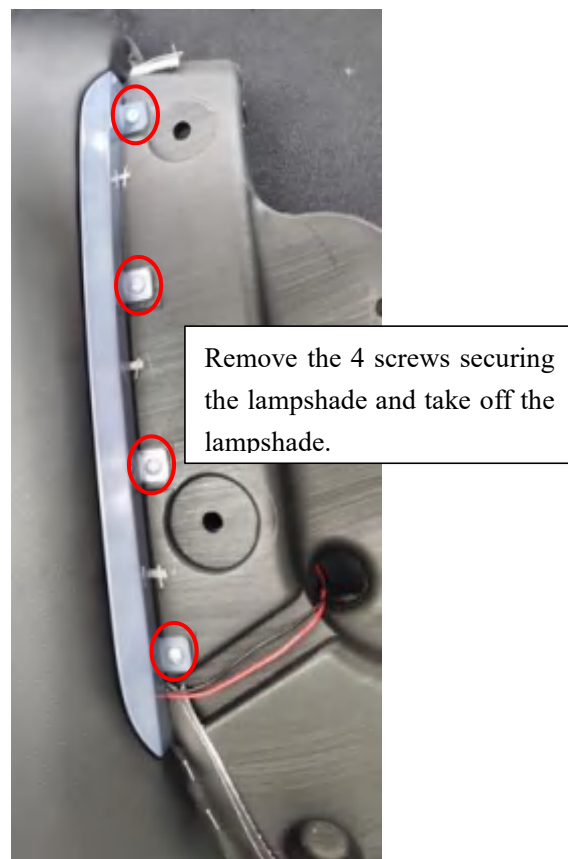
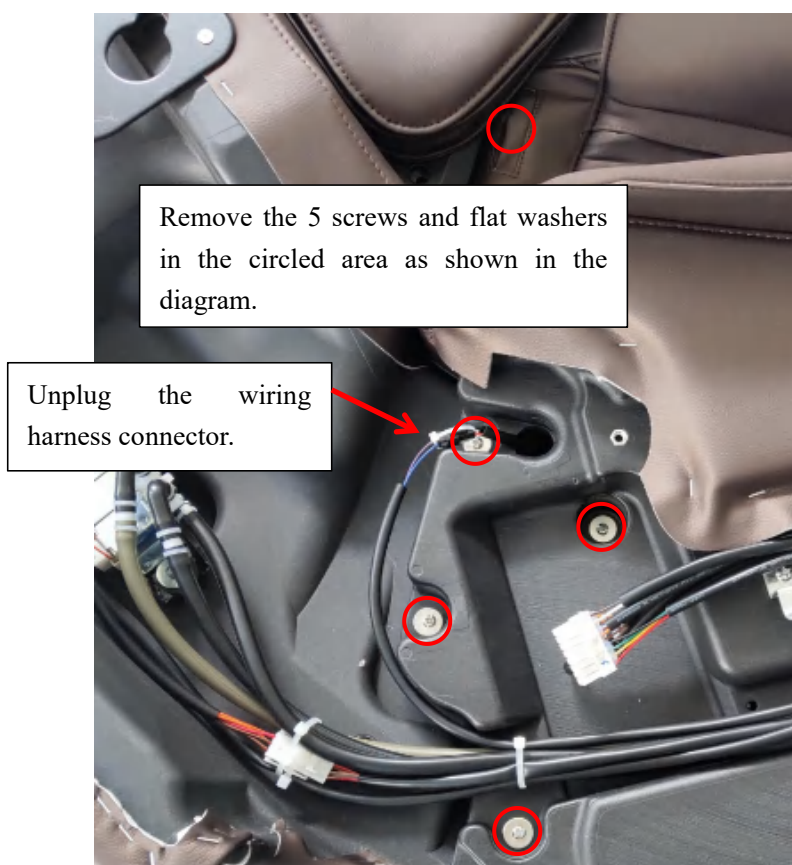

## 2.9 Replace the Right Armrest Physiological Detection Module

2.9.1 Remove the upper cover of the physiological detection module: At the front end of the right armrest where the arm is placed, pull up hard to remove the upper cover (buckle installation structure), and unplug the wiring harness connector.

2.9.2 Replace the physiological detection module: Remove the 2 ST2.2×4.5 screws fixing the module, then the module can be replaced.

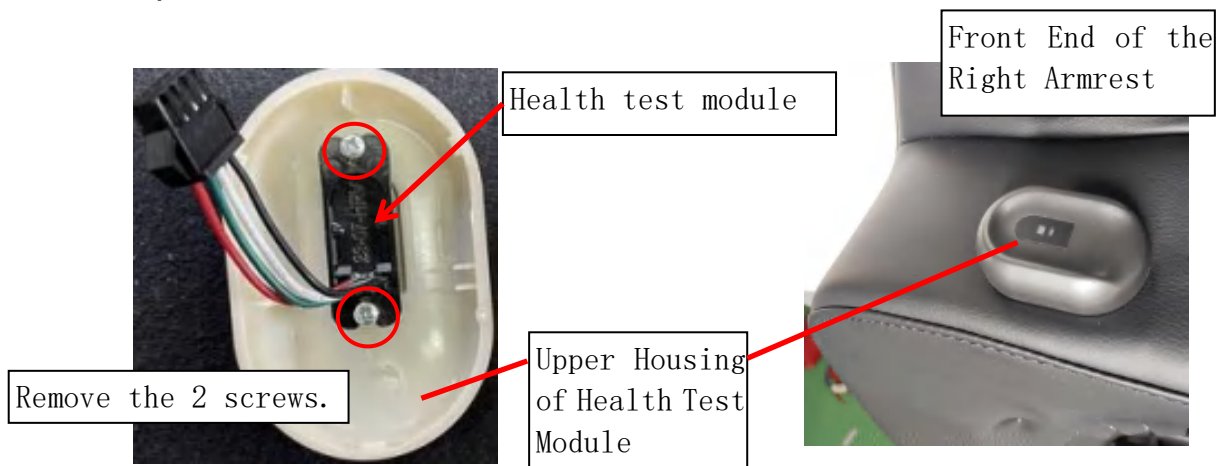

## 3. Removal of Leg and Foot Parts

### 3.1 Replacement of Foot Solenoid Valve

3.1.1 Operate the remote control to raise the leg and foot parts.

3.1.2 Removal of the foot bottom shell: Remove the screws ST4.2\*25 securing the foot bottom cover, then take off the foot bottom shell. The foot bottom shell and the foot part adopt a buckle structure.

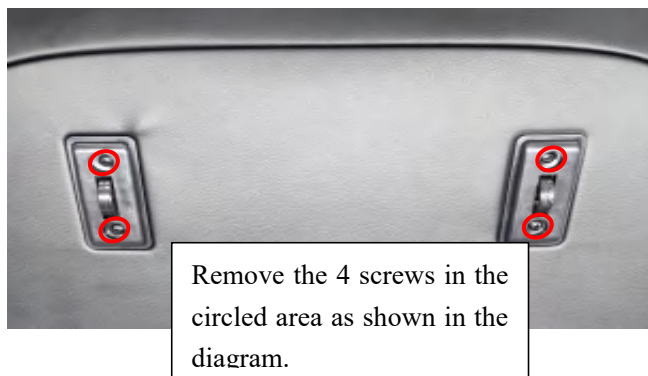

3.1.3 Replace the foot solenoid valve: Remove the 4 fixing screws ST3.9×9.5 from the foot part, cut off the nylon cable ties securing the air tubes and wiring harness, and unplug the air tubes and wiring harness. Then remove the 4 screws ST3.9×9.5 fixing the solenoid valve and its adapter board, and the solenoid valve can be replaced.

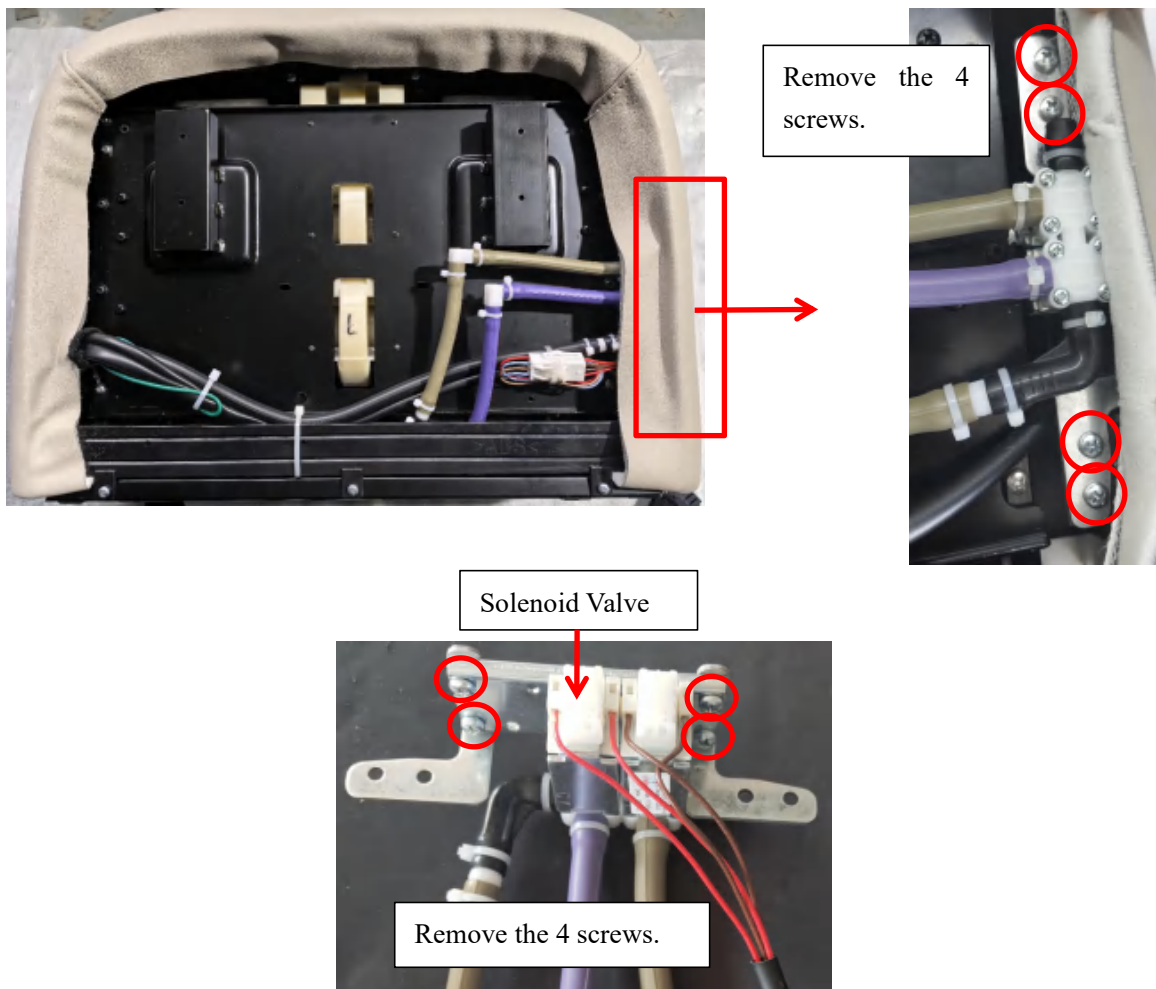

3.2 Replace the leg and foot assembly: Lift the seat cushion upward to expose the upper end of the leg and foot parts. Remove one screw ST5×16 on each left and right side, lift up the rotating shaft pressure plate, lift the leg and foot assembly to disengage it upward and then lower it, unplug the air tubes and connectors at the rear of the assembly, and the leg and foot assembly can be replaced.

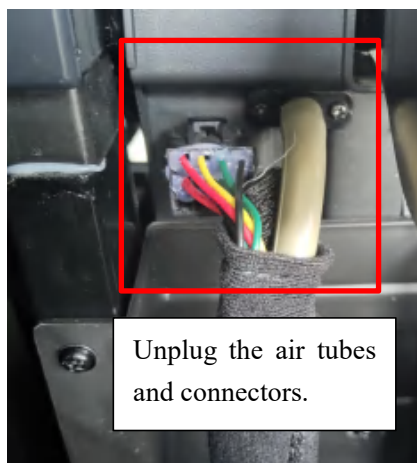

Remove the screws and lift up the spindle pressure plate.



Legrest assy

### 3.3 Replace the Foot Massage Rollers

Remove the leg and foot assembly according to 3.2.

3.3.1 Remove the upper and lower rear leg covers: Use a Phillips screwdriver to remove the screws securing the upper and lower rear leg covers. Remove the lower cover first, then the upper cover.

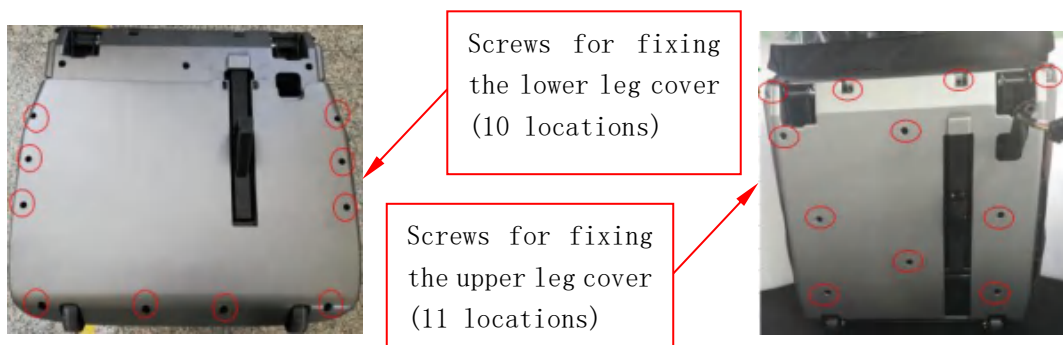

3.3.2 Disassemble the foot assembly:

(1) Remove the cable ties binding the foot wiring harness, separate the leg and foot wiring harness connectors, and unplug the purple air tube on the leg.

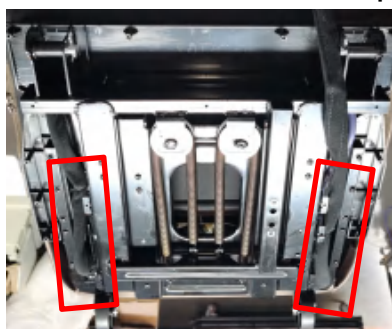

(2) Remove the screws M6×16 fixing the foot part, then the foot assembly can be removed.

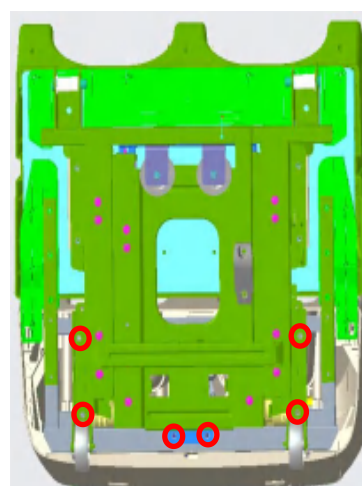

Remove the 6 screws in the circled area as shown in the diagram.

Remove the foot bottom shell according to 3.1.2.

3.3.3 Remove the screws in the circled area as shown in the diagram, remove the cable ties securing the wiring harness of the foot massage rollers, and unplug the wiring harness of the foot massage rollers.

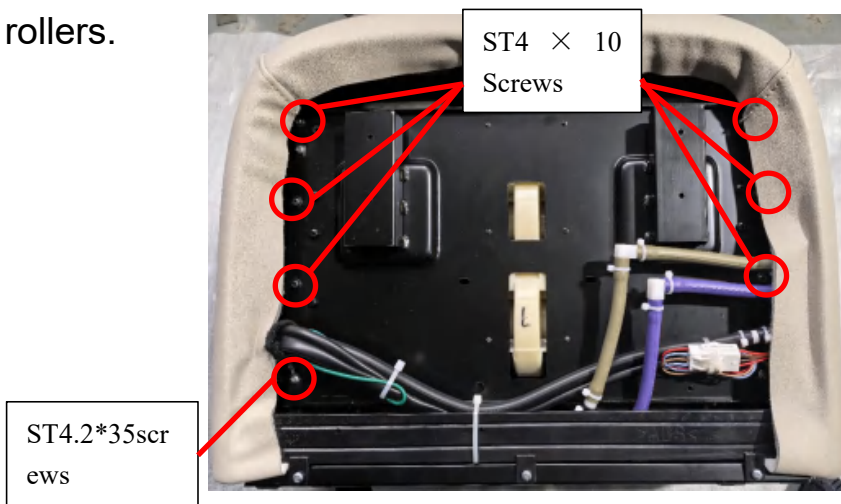

3.3.4 Remove the mounting screws of the foot massage rollers, then the foot massage rollers can be replaced.

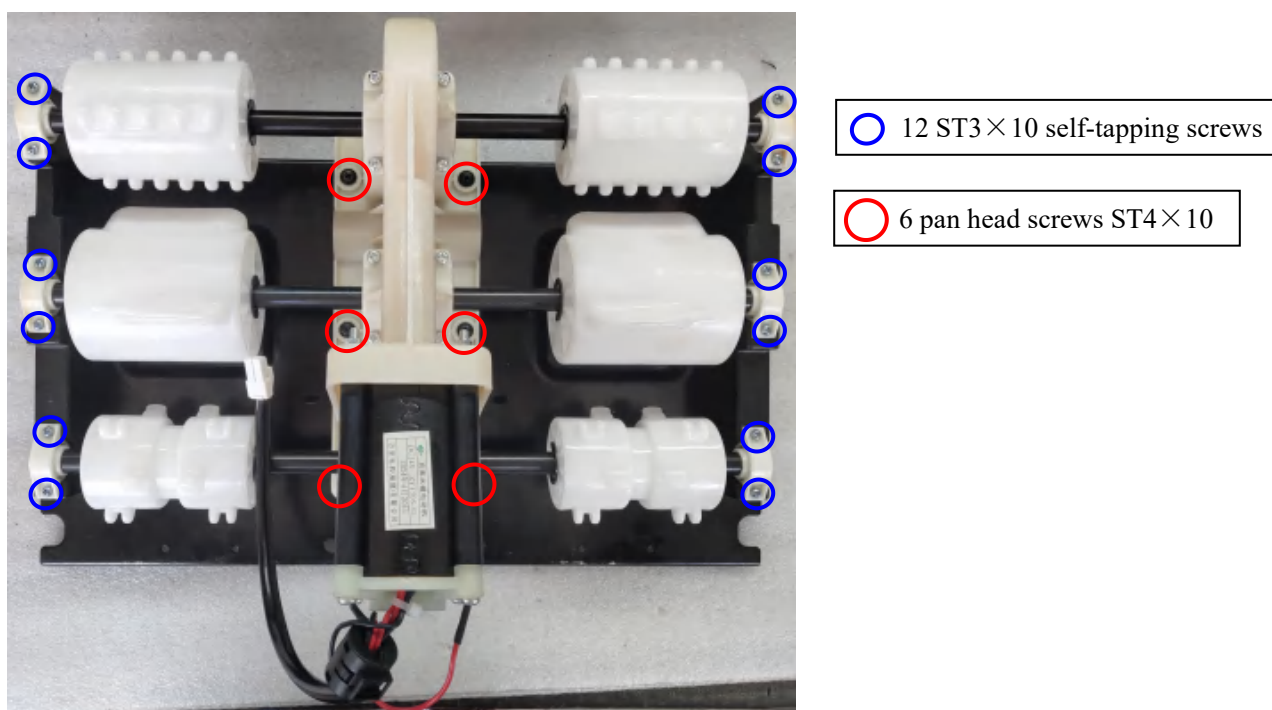

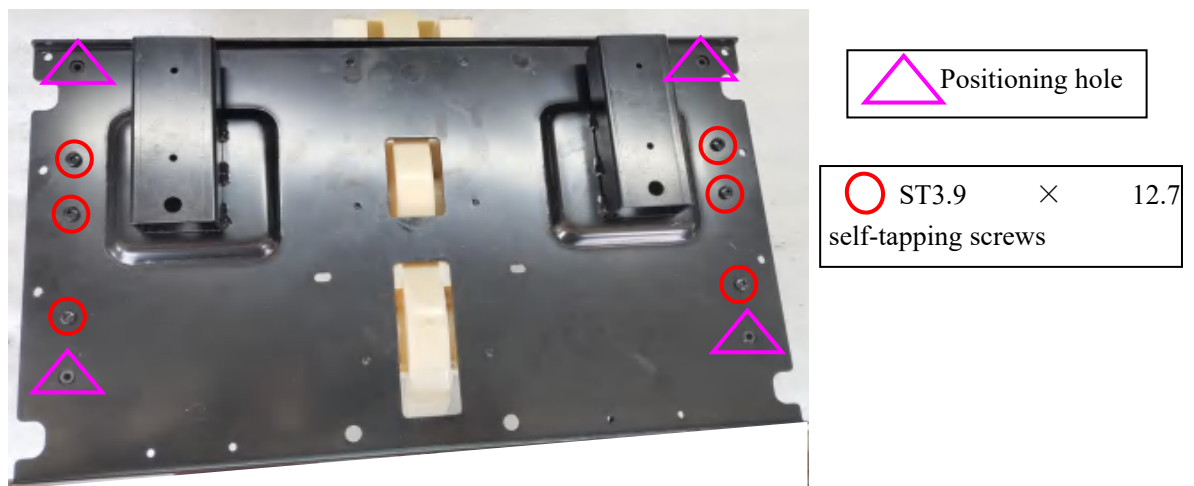

### 3.4 Replace the leg solenoid valve

3.4.1 Remove the leg and foot assembly according to 3.2.

3.4.2 Remove the upper and lower rear leg covers according to 3.3.1.

3.4.3 Disassemble the leg assembly

(1) Remove the cable ties binding the foot wiring harness, separate the leg and foot wiring harness connectors, and unplug the purple air tube from the leg.

(2) Remove the 4 M6×16 screws fixing the leg part, then the leg assembly can be removed.

3.4.4 Disassemble the leg solenoid valve

(1) Unzip the sewn product at the rear of the leg, and remove the 10 screws fixing the leg frame.

(2) Remove the 2 screws and flat washers fixing the solenoid assembly, unplug the air tubes on the solenoid valve, then remove

the 4 ST3×10 screws fixing the solenoid valve, and the solenoid valve can be replaced.

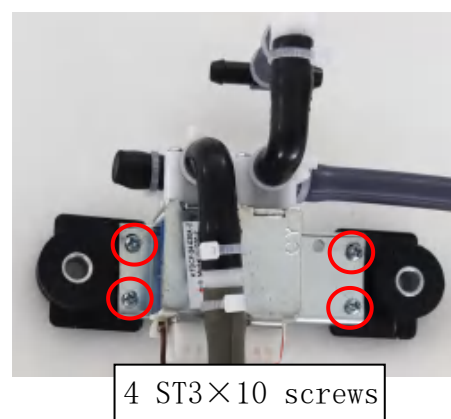
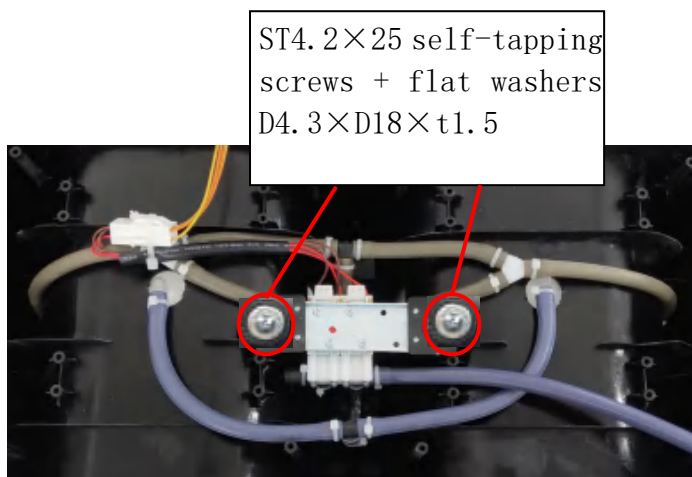
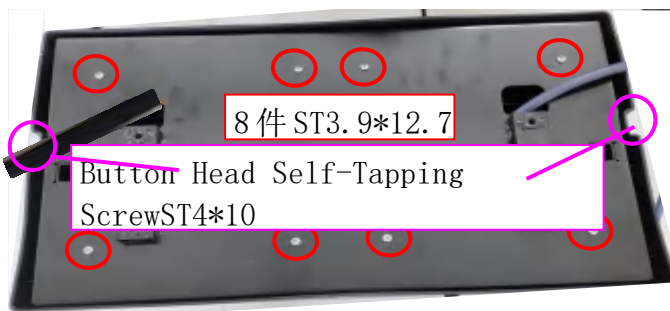
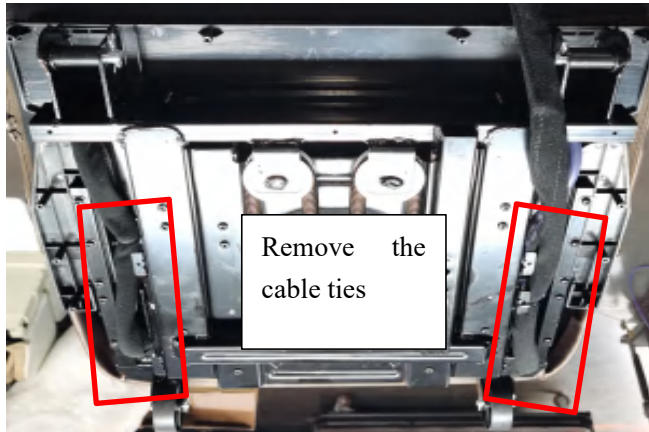

## 4. Replacement of the Main Circuit Board, Air Pump and Transformer

4.1 Removal of the Rear Cover: Remove the 2 screws securing the rear cover, firmly release the 2 ball joints, and the rear cover can be taken off.

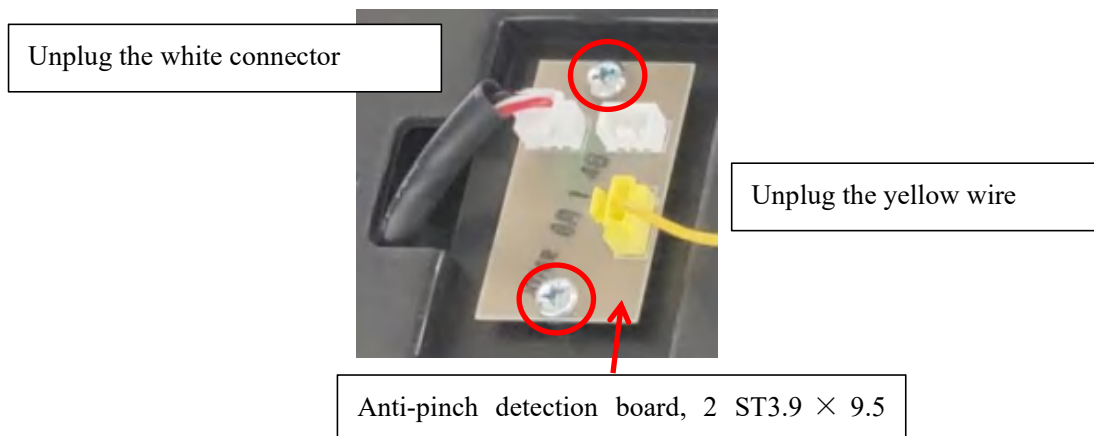
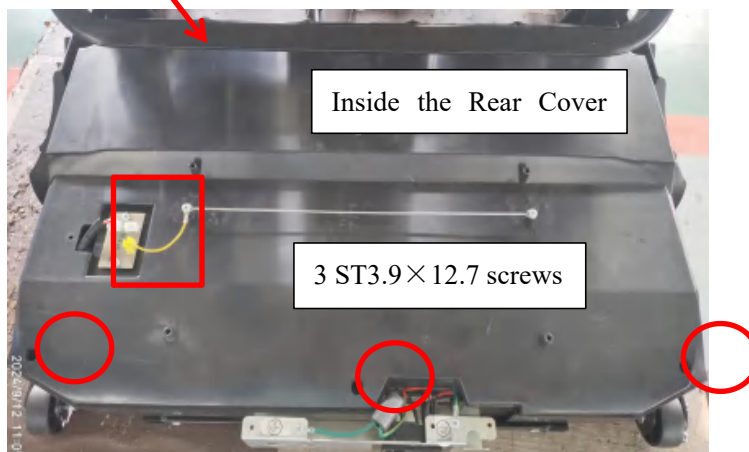
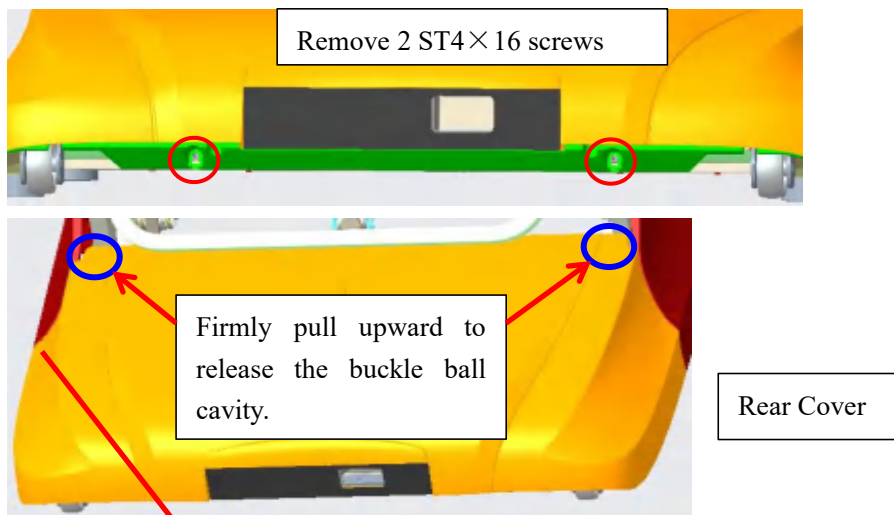

#### 4.2 Replacement of the anti-pinch detection board:

Remove the 2 screws fixing the anti-pinch detection board and unplug the yellow wiring harness, then the anti-pinch detection board can be replaced.

#### 4.3 Removal of the rear cover inner shell:

Remove the 3 screws fixing the rear cover inner shell and unplug the white connector on the anti-pinch switch, then the rear cover inner shell can be removed.

#### 4.4 Replacement of the main circuit board, air pump and transformer:

Remove the cable ties, unplug the relevant wiring harnesses and air tubes, remove the fixing screws, and they can be replaced.

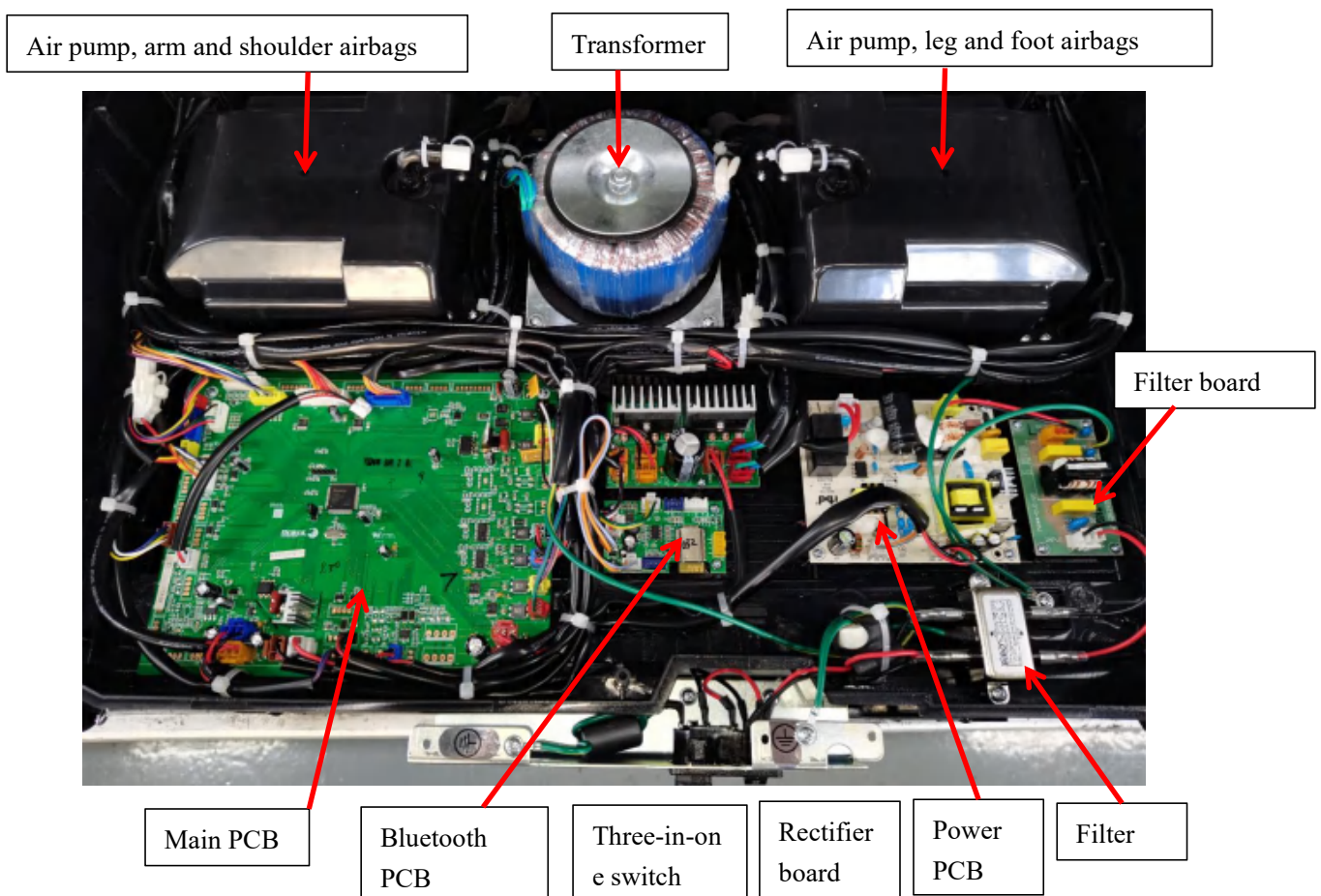

## 5. Replacement of Electric Support Rod

### 5.1 Replacement of Backrest Electric Support Rod

Lay the massage chair on its side, remove the cotter pins and shaft pins fixing both ends of the support rod, unplug the wiring harness of the electric support rod, then the electric support rod can be replaced. Note that the shaft pins should be coated with TE-082 grease.

### 5.2 Replacement of Leg and Foot Electric Support Rod

Remove the leg and foot assembly according to Section 3.2

#### 5.2.1 Removal of the Front Baffle:

Remove the 12 screws securing the front baffle as circled in the diagram, then take off the front baffle.

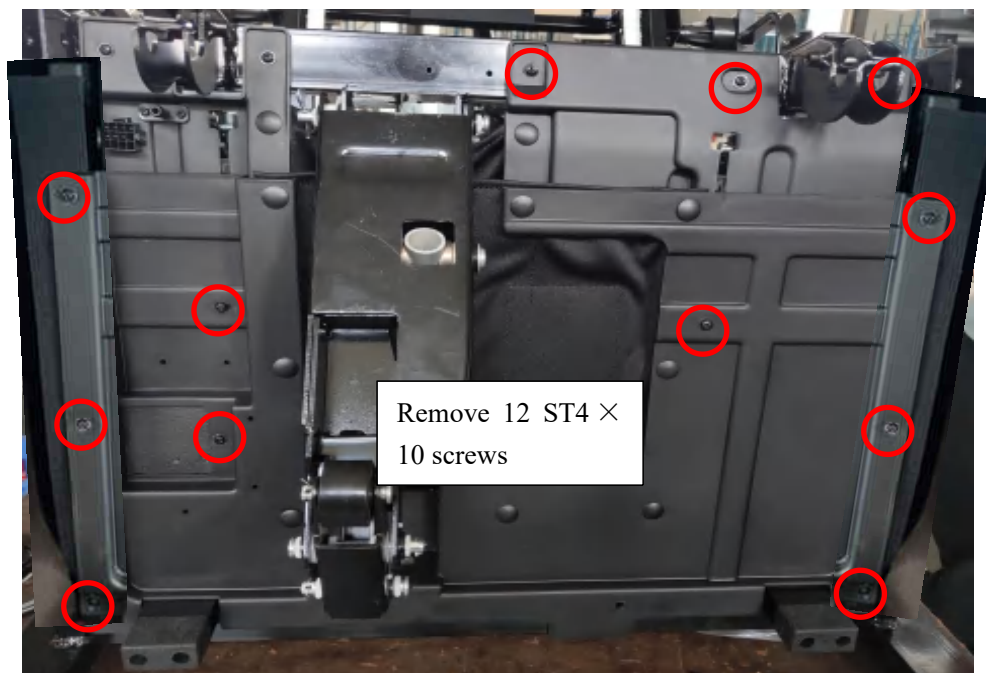

### 5.2.2 Replacement of Leg and Foot Electric Support Rod:

First remove the B8×110 shaft pin as shown in the diagram, then remove the B10×70 shaft pin, followed by the B8×50 shaft pin, and unplug the wiring harness of the electric support rod. Then the electric support rod can be replaced. When installing the support rod, take care not to miss installing washers and other parts.

Note that the shaft pins should be coated with TE-082 grease.

#### IV. Layout Diagram of Main Circuit Board Components

