



A503-2按摩椅售后维修指南

1、Chair size



Chapter two : Basic Control Principles

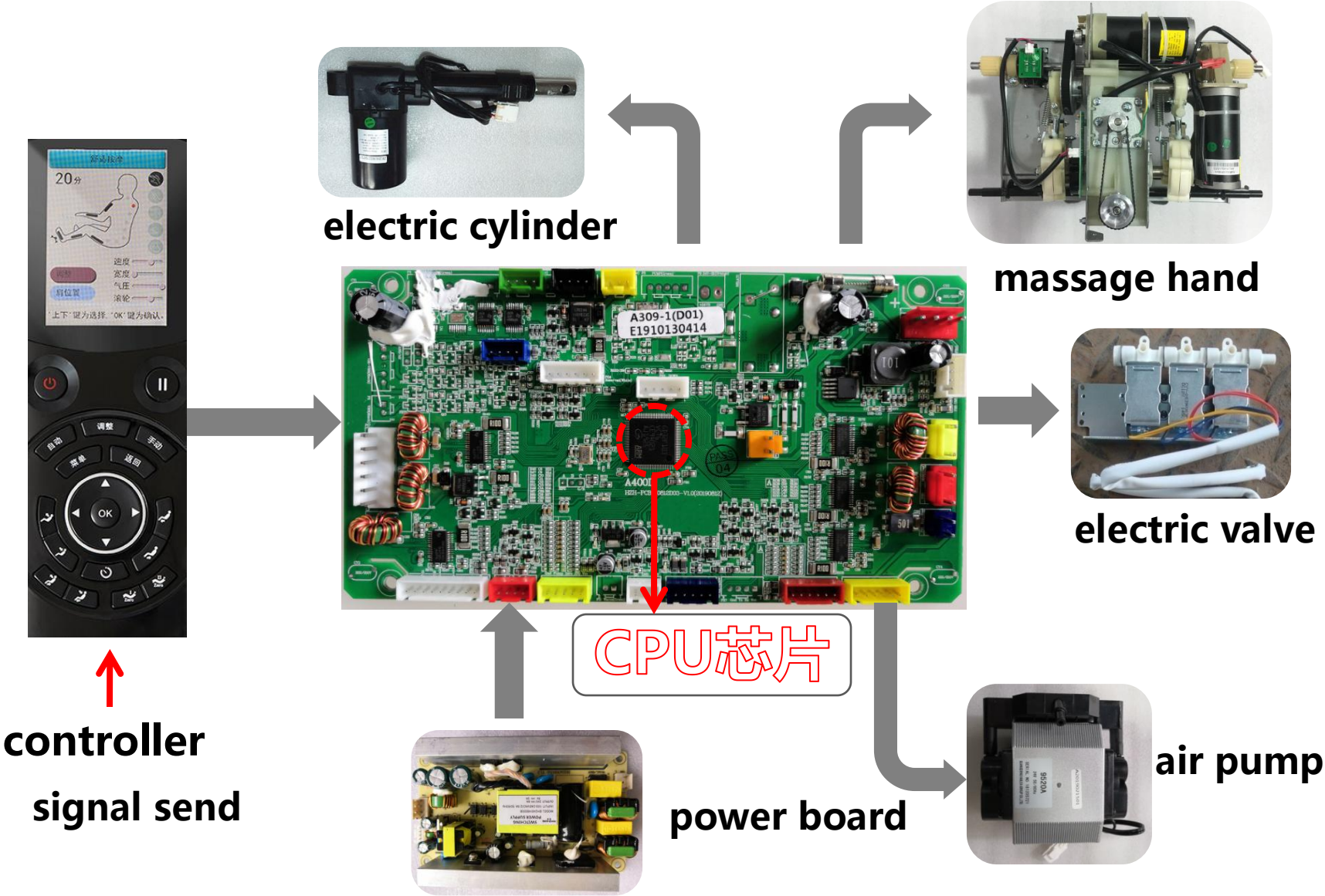

3.1 Internal Distribution of the Main Unit

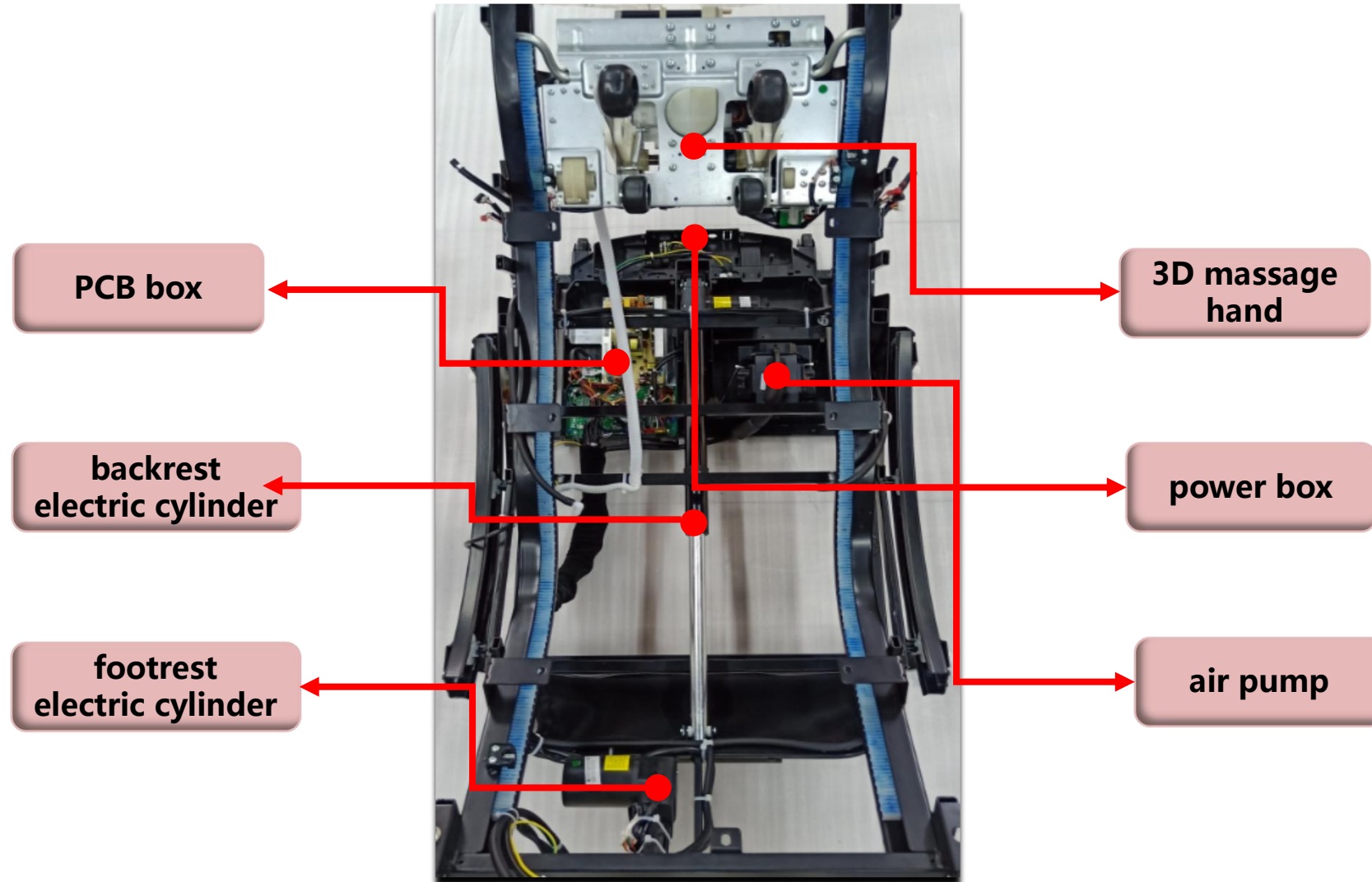

3.2 Internal Structure of the Product

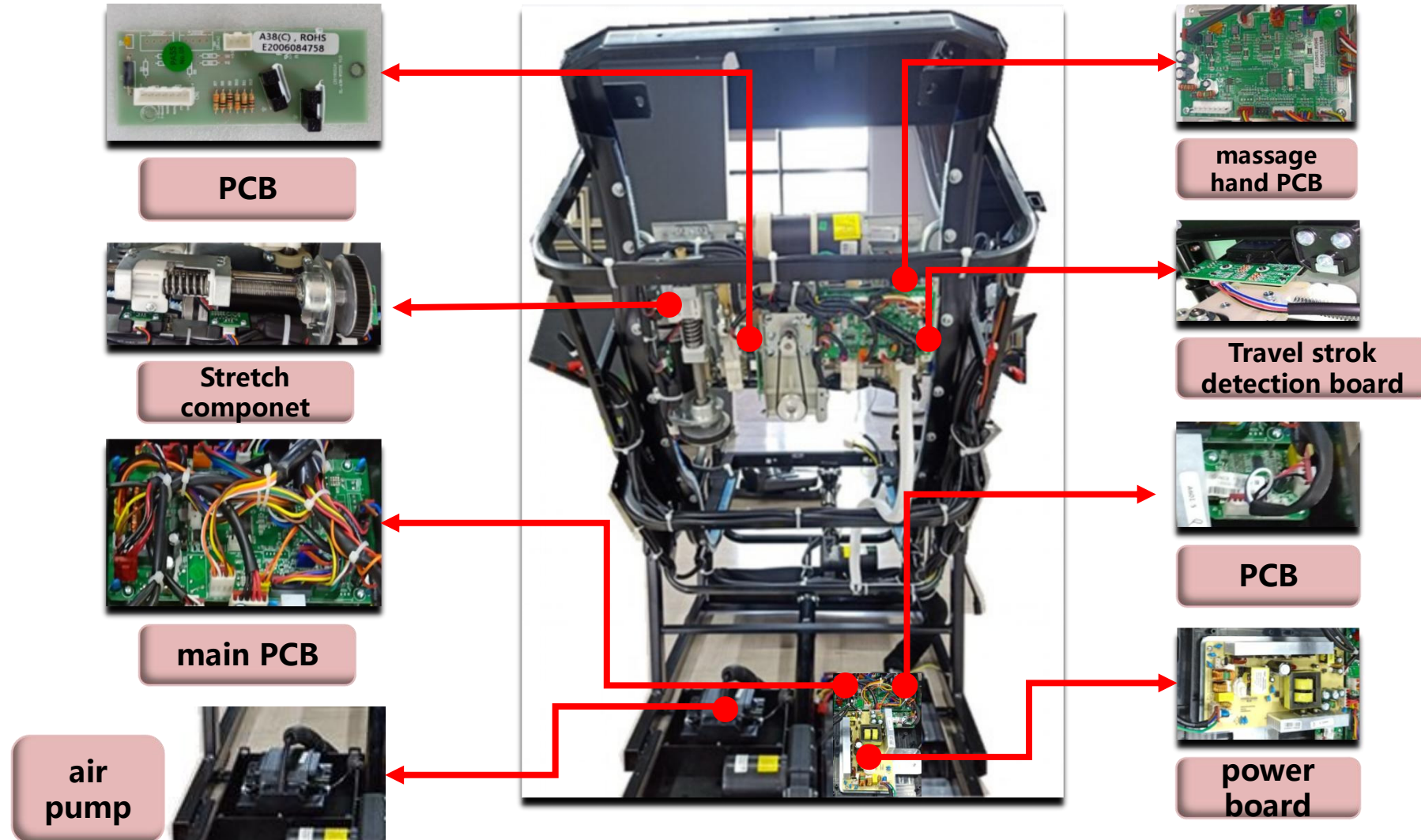

3.3 Massage Hand Assembly Distribution Diagram

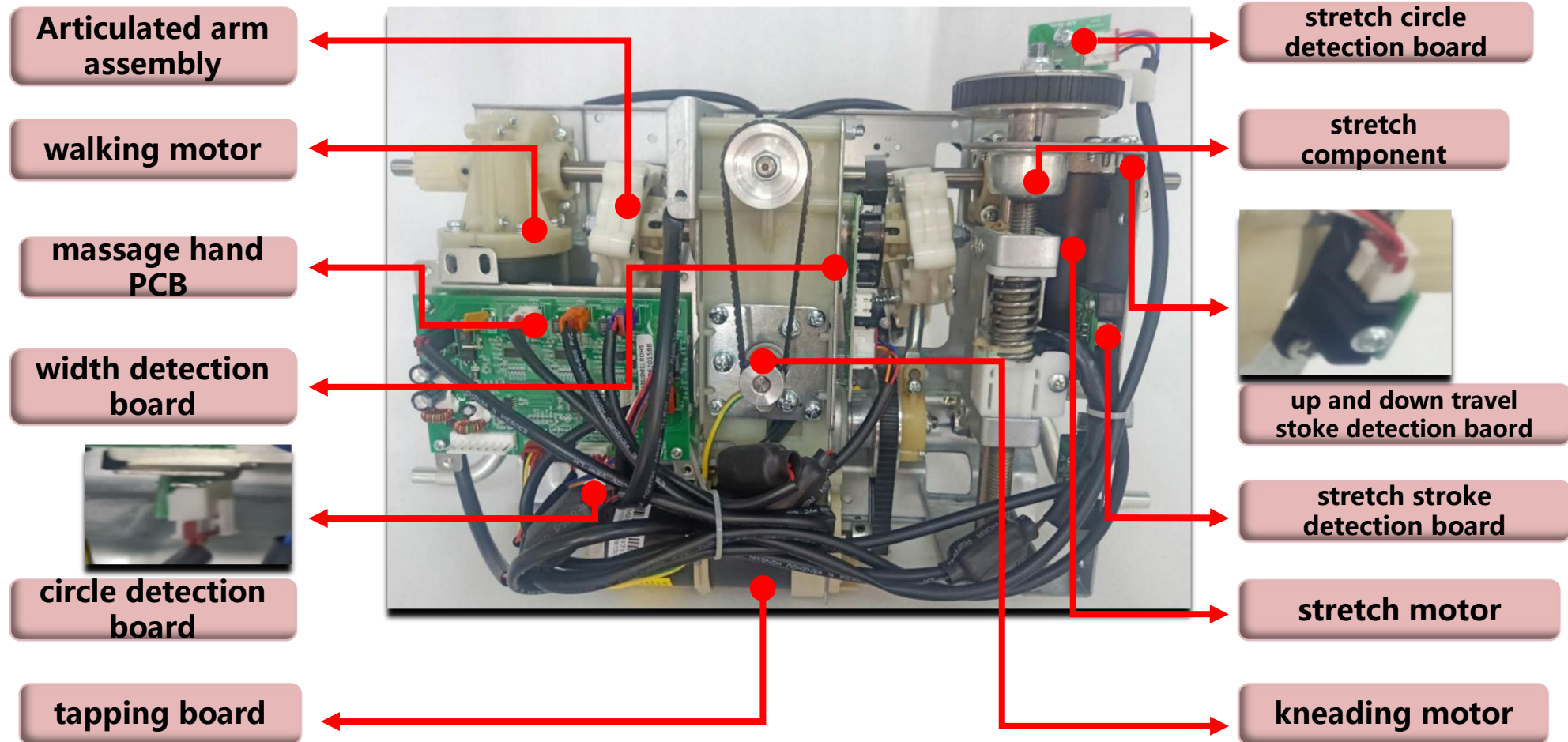

3.4 Drive Board Distribution Diagram

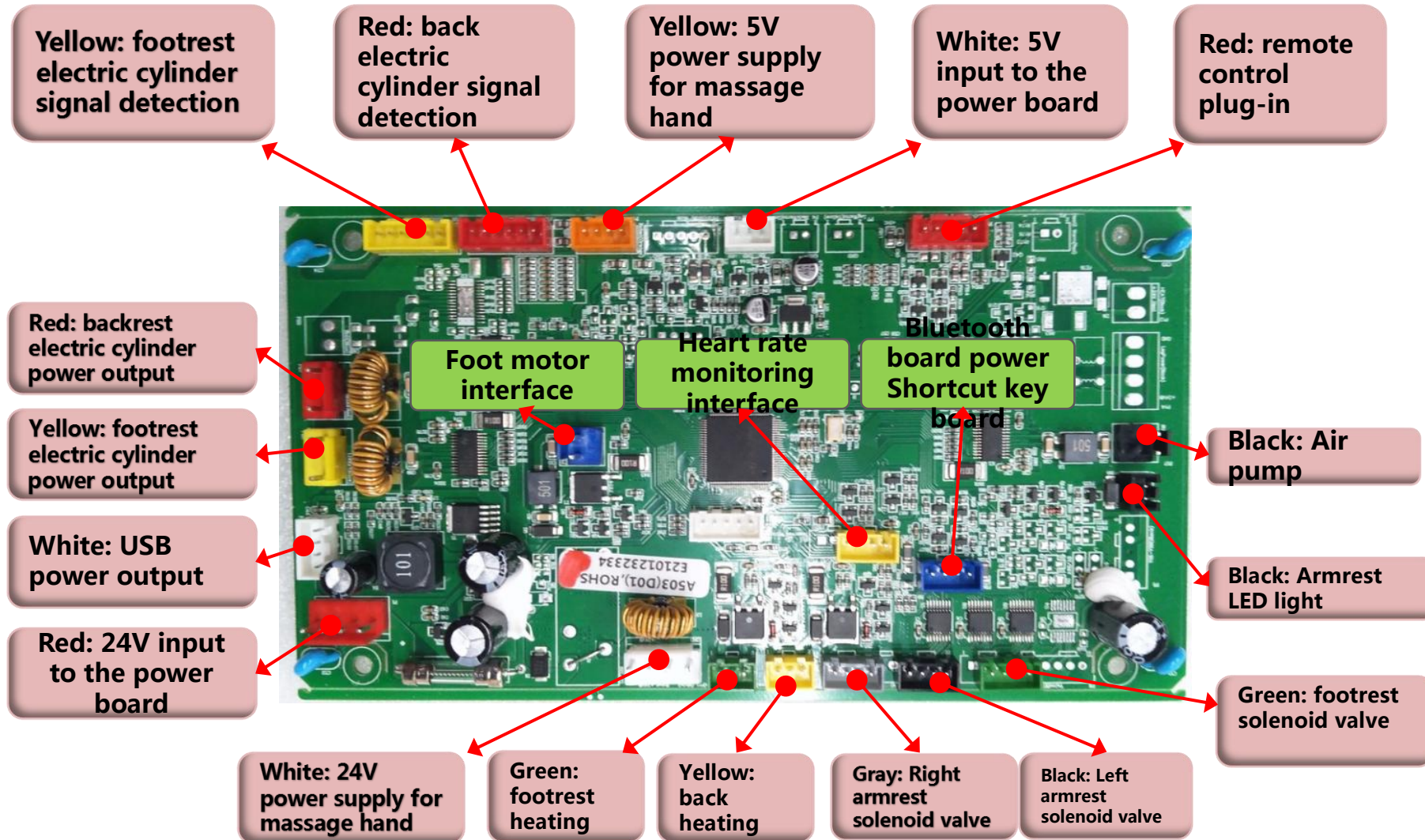

3.5 Switching Power Supply Distribution Diagram



4.1、 Disassembly Diagram of Back Cushion Component

1、 1. Remove the zip at the yellow positions 1 to 7 on the inner side of the backrest cushion edge as shown in the figure.

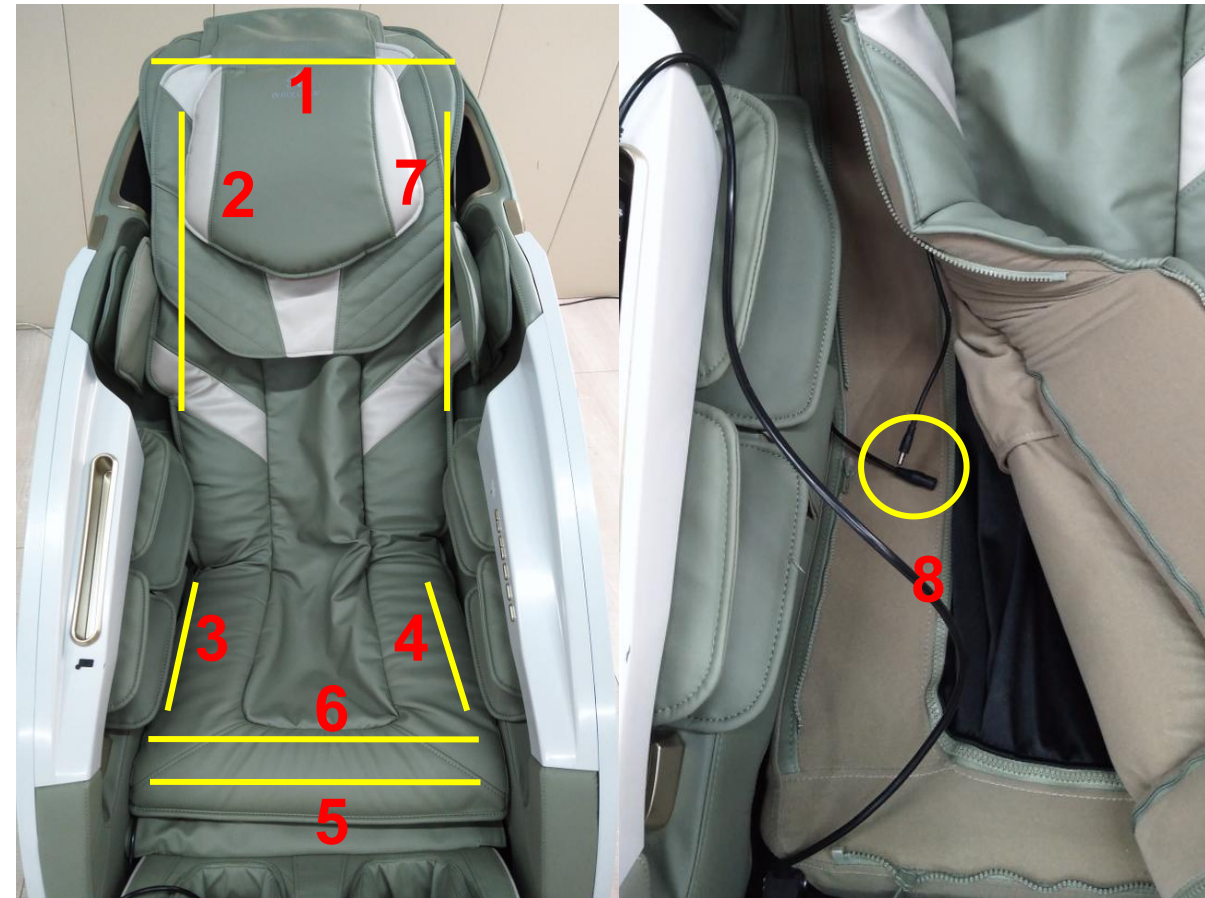

2、 Remove the heating connector at position 8 in the figure to take off the back cushion component.

4.2、 Disassembly Diagram of Footrest Component



A

A、 Remove the screws 1 to 2 at the installation seat in Figure A



B

B、 Separate the air hose and plug at position 3 in Figure B



C

C、 Remove the footrest component.

4.3、 Disassembly Diagram of Backrest Cover and Drive Box Cover



A

A、 Remove the screws in Figures A1 to 4 to take off the back cover

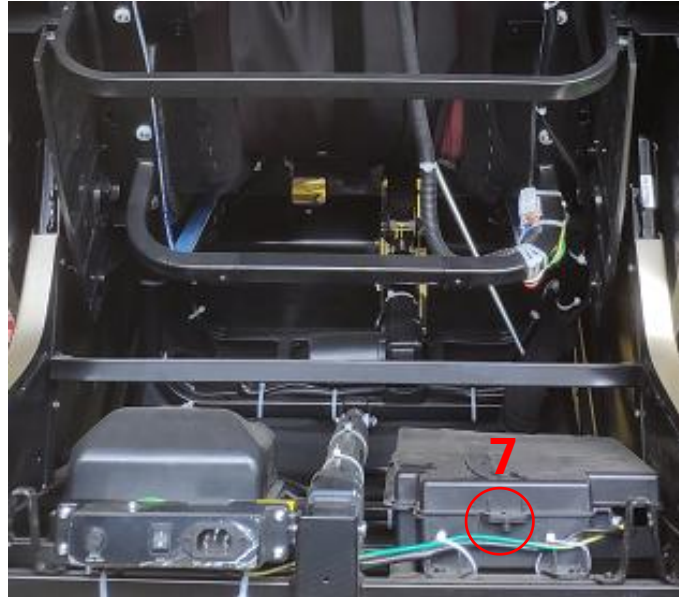

B

B、 Remove the screws 5 to 6 from Figure A to take off the back cover as shown in Figure B



C

C、 Remove the screw 7 in Figure B and the drive box cover can be taken off as shown in Figure C

4.4、 Disassembly Diagram of Space Cabin (Note: Remove the fixing screws of the left and right armrests)

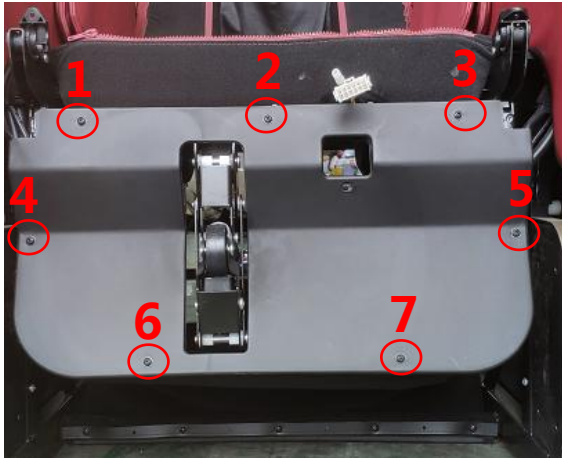
**A**

A、 Remove the screws 1 to 7 in Figure A to take off the front panel.

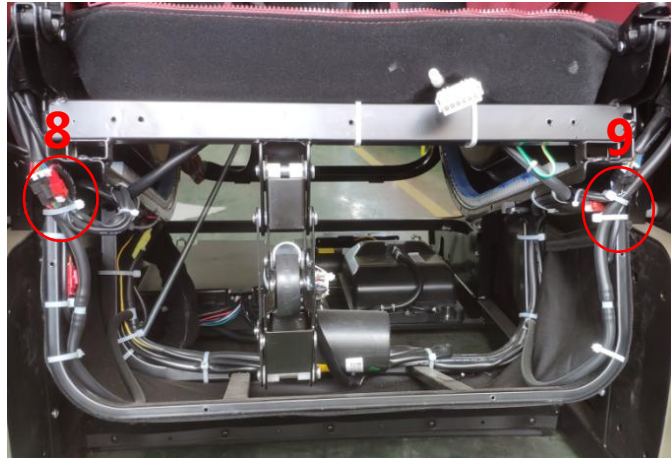
**B**

B、 Remove the zip ties at positions 8 to 9 in Figure B

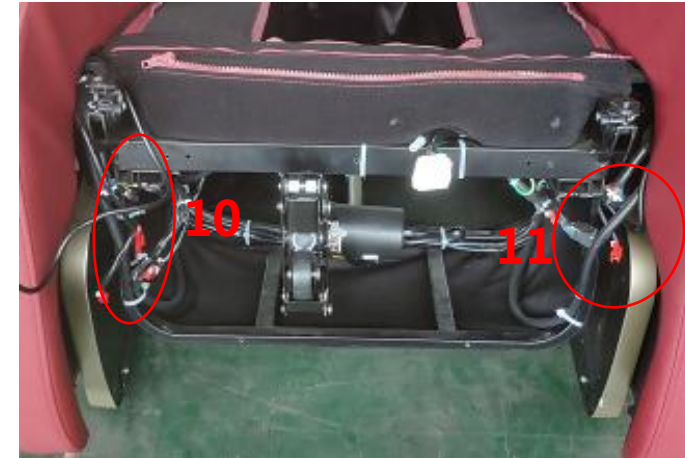
**C**

C、 Remove the three plugs and air hose at positions 10 to 11 in Figure C.

4.5、 Disassembly Diagram of Space Cabin (Note: Remove the fixing screws of the left and right armrests)

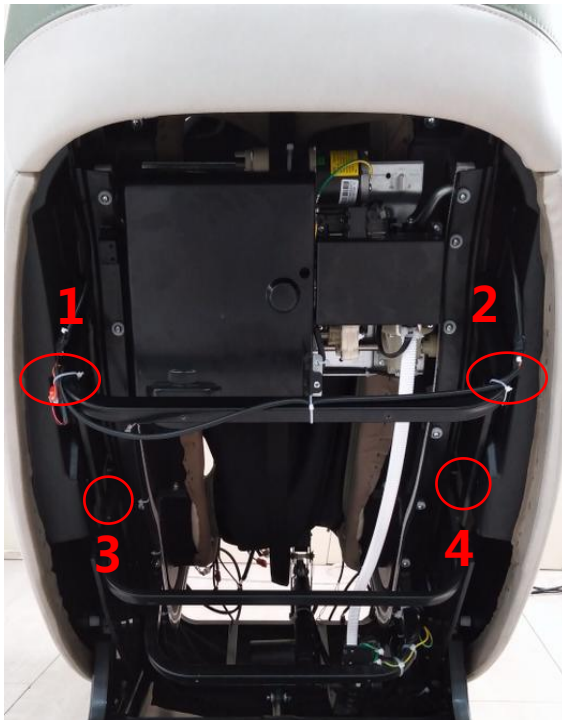
**A**

A、 Remove the plugs in Figures A1 to A2 and the screws at positions 3 to 4

**B**

B、 As shown in Figure B, slightly lift the armrest upwards to remove the space capsule (it is recommended two people operate , one in front and the other behind).第13页 / 共48页

4.6、 Disassembly Diagram of Backrest Frame

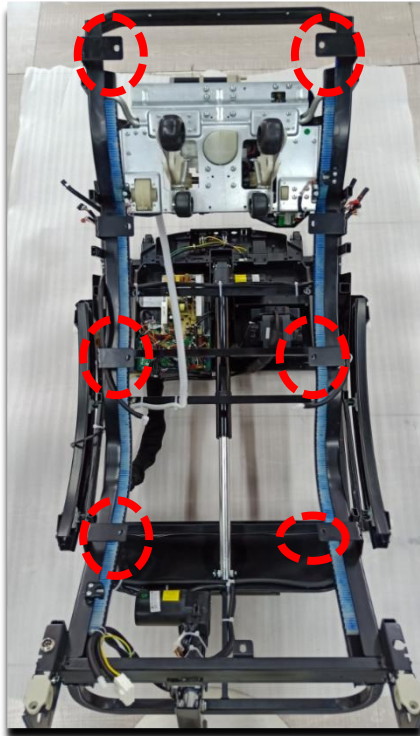

A

A、 Remove the six screws in Figure A



B

B、 Remove the yellow screw in Figure B



C

C、 Take out the backrest cover

4.7、 Disassembly Diagram of Massage Hand

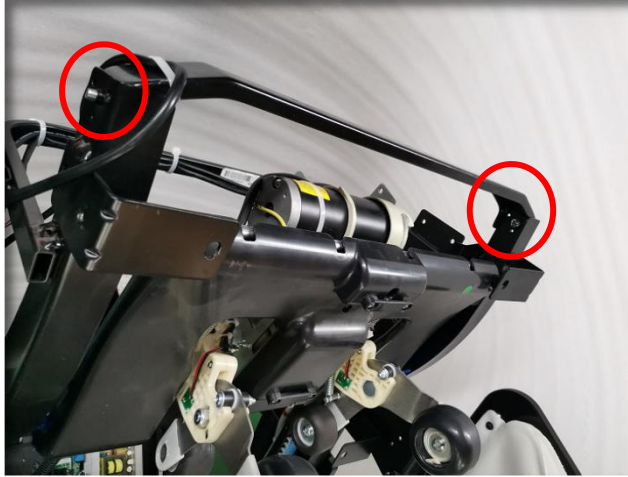

A、 Take off the screws at the two sides of the backrest frame (take out the capsule of the backrest cover first)

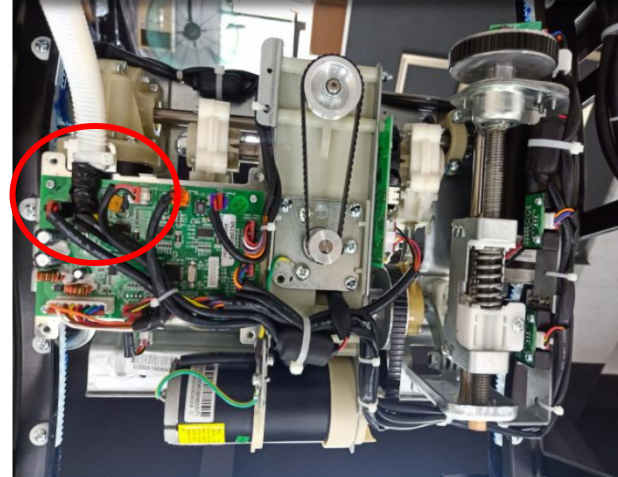

B、 Separate the cable tie as the red circle, take out the ground wire screw and magnet of the limit switch (take photo of the cables first, then you know how to install back_



C、 Remove the massage hand and separate it from the machine (make sure the power off before you take out the massage hand).

4.8、 Disassembly Diagram of Side Cover Component

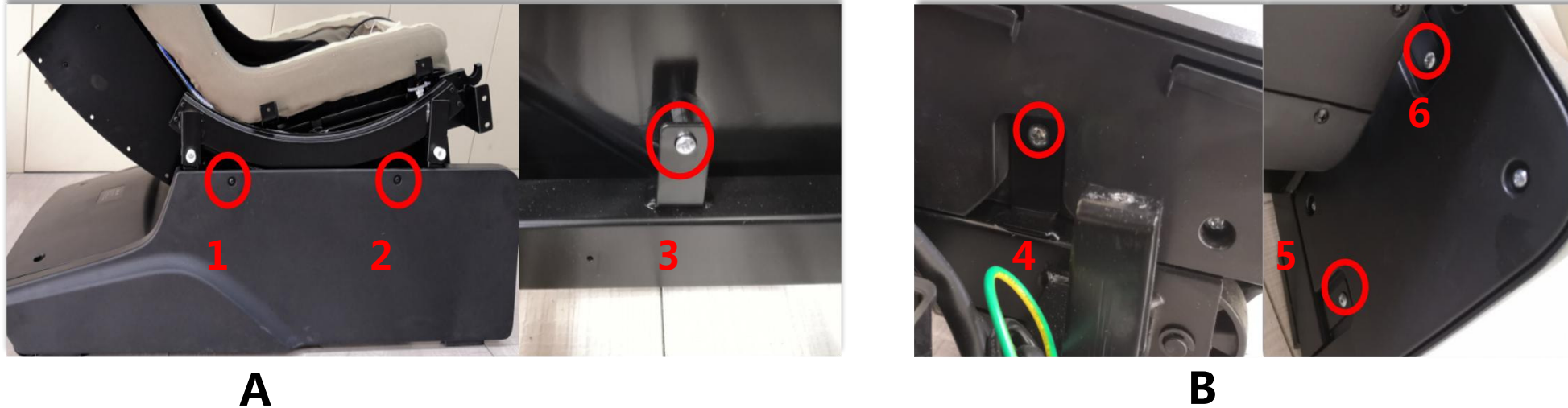

A、 Remove the screws 1, 2 and 3 in the middle of the side cover

B、 Remove screw 4 at the rear end of the side cover and 5 and 6 at the front end, and then you can take off the side cover assembly

4.9、 Disassembly Diagram of Backrest Electric Cylinder

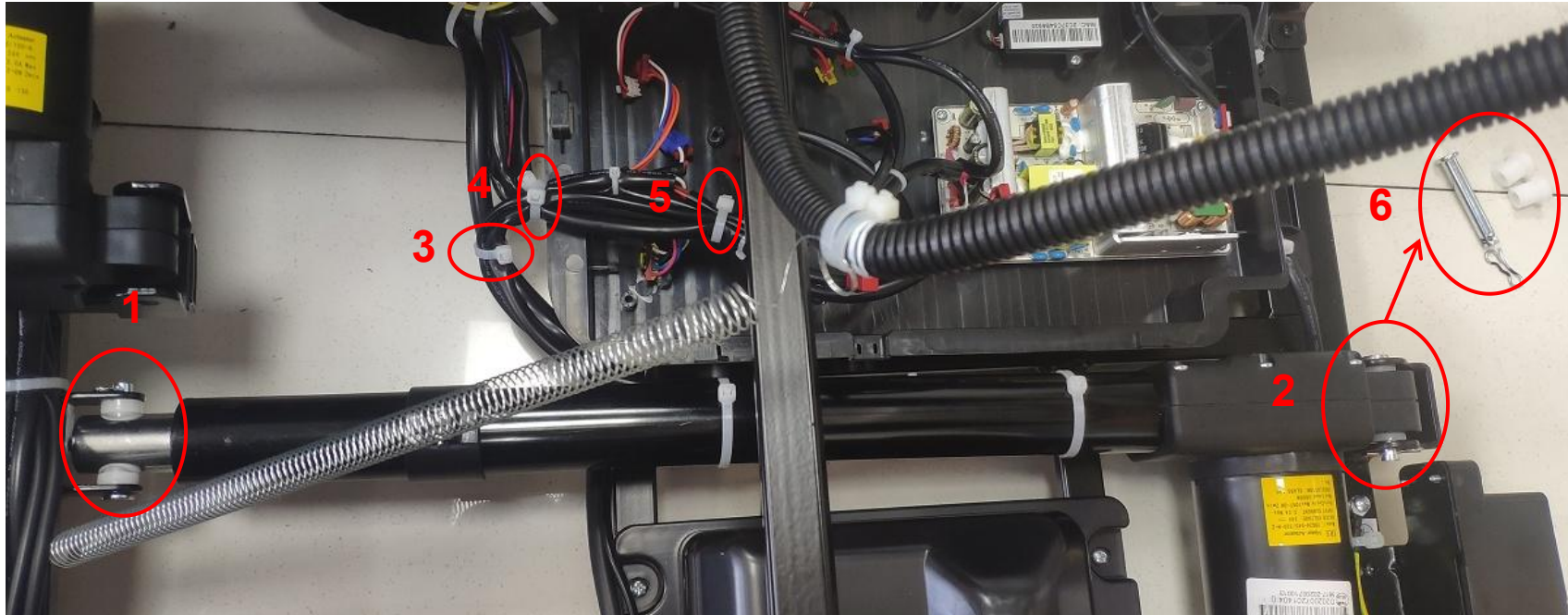

- 1、 Remove the zip ties at positions 3 to 5 in the figure, and take out the two red plugs of the electric cylinder.
- 2、 Remove the R-shaped pins and pins at positions 1 and 2 as shown in the figure , then take out spring 6 to take out the electric cylinder.

4.10、 Disassembly Diagram of Footrest Electric Cylinder

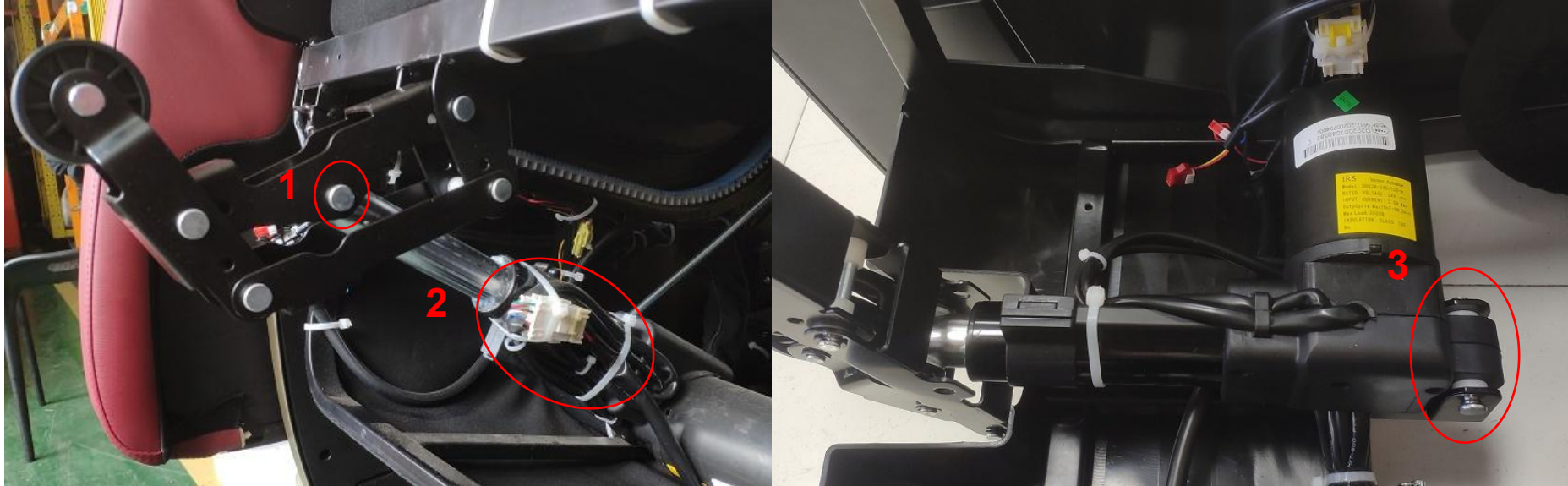

A

B

1、 Remove the retaining ring and pin at position 1 in Figure A, remove the zip tie at position 2, and separate the electric cylinder plug.

2、 Remove the R-shaped pins and pins at position 3 in Figure B to take out the electric cylinder.

4.11、 Disassembly Diagram of Armrest Airbags



A



B



C

A Remove the zipper in Figure

B Separate the four air pipes in Figure B

C Take out the airbags

4.12、 Disassembly Diagram of Shoulder Airbags



A

A Zip out



B

B Take out the air hose



C

C Tke out the screws and remove the airbags

4.13、 Disassembly Diagram of Armrest Outer Cover



A

A Take out the 3 screws



B

B Insert the flat-head screwdriver into the inner side of the outer cover edge, slightly lift it up, and then remove the outer cover



C

C Take off the outer cover

4.14、 Disassembly Diagram of Shortcut Key Board



A

A、 Take out the 6 screws

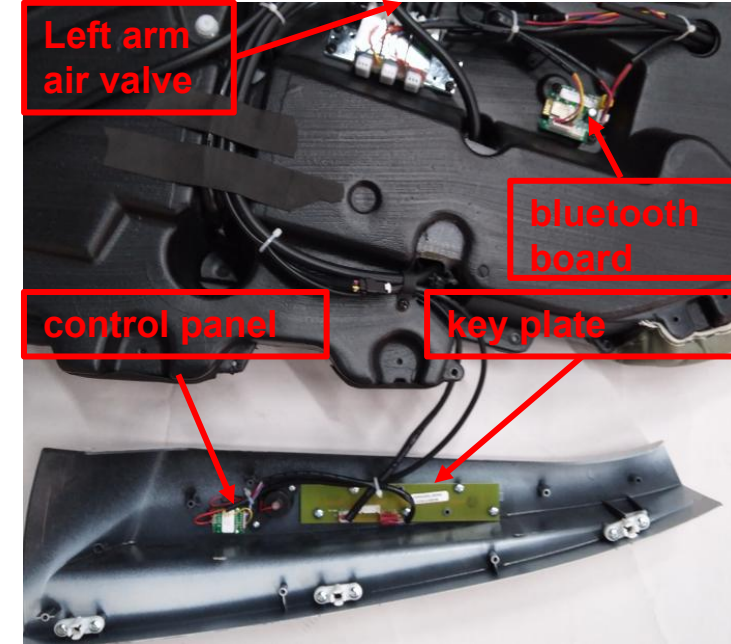

B

B Remove the five screws of the key plate and the key plate can be taken off

4.15、 Disassembly Diagram of Control Box



A

A Take out the 3 screws



B

B Insert the flat-head screwdriver into the inner side of the outer cover edge, slightly lift it up, and then remove the outer cover



C

C Remove the three screws in Figure 3 to take out the control box.

4.16、 Schematic Diagram of Speaker Component Disassembly

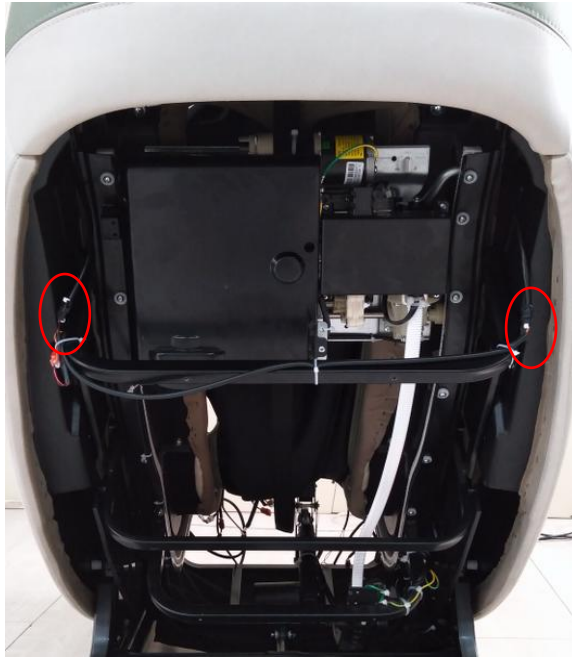

A



B



C

A. separate the plugs as photo

B. Insert the flat-head screwdriver into the inner side of the outer cover edge, slightly lift it up, and then remove the outer cover.

C. Remove the horn assembly (Note: If the car buckle is damaged, then replace a new one).

4.17、 Schematic Diagram of Heart Rate Monitor Disassembly

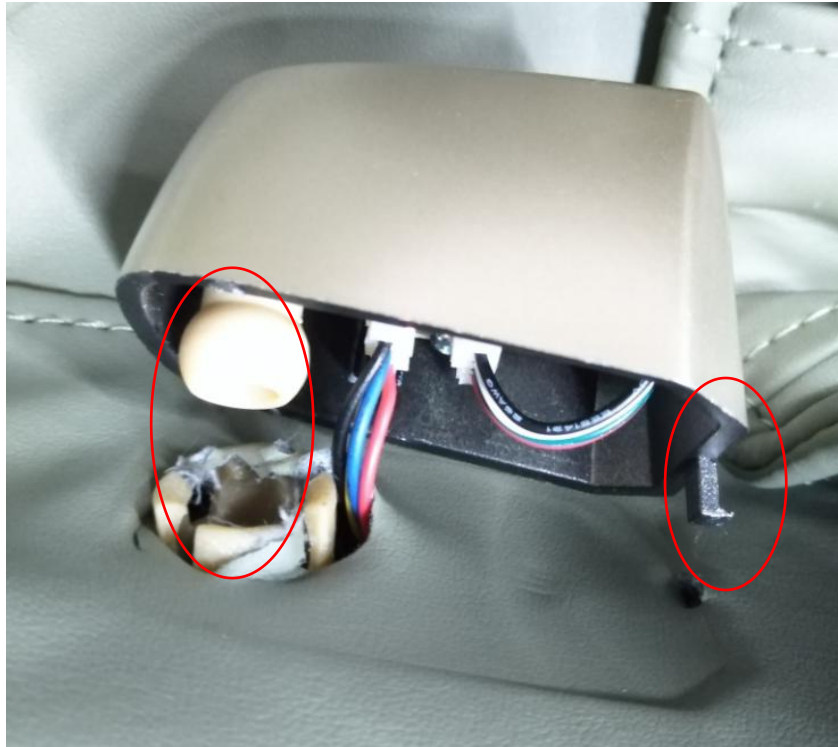

A

A. Insert the flat-head screwdriver into the inner side of the outer cover edge, slightly lift it up, and then remove the outer cover



B

B. Remove the plugin in Figure B

4.18、 Schematic Diagram of Foot Roller Motor Disassembly

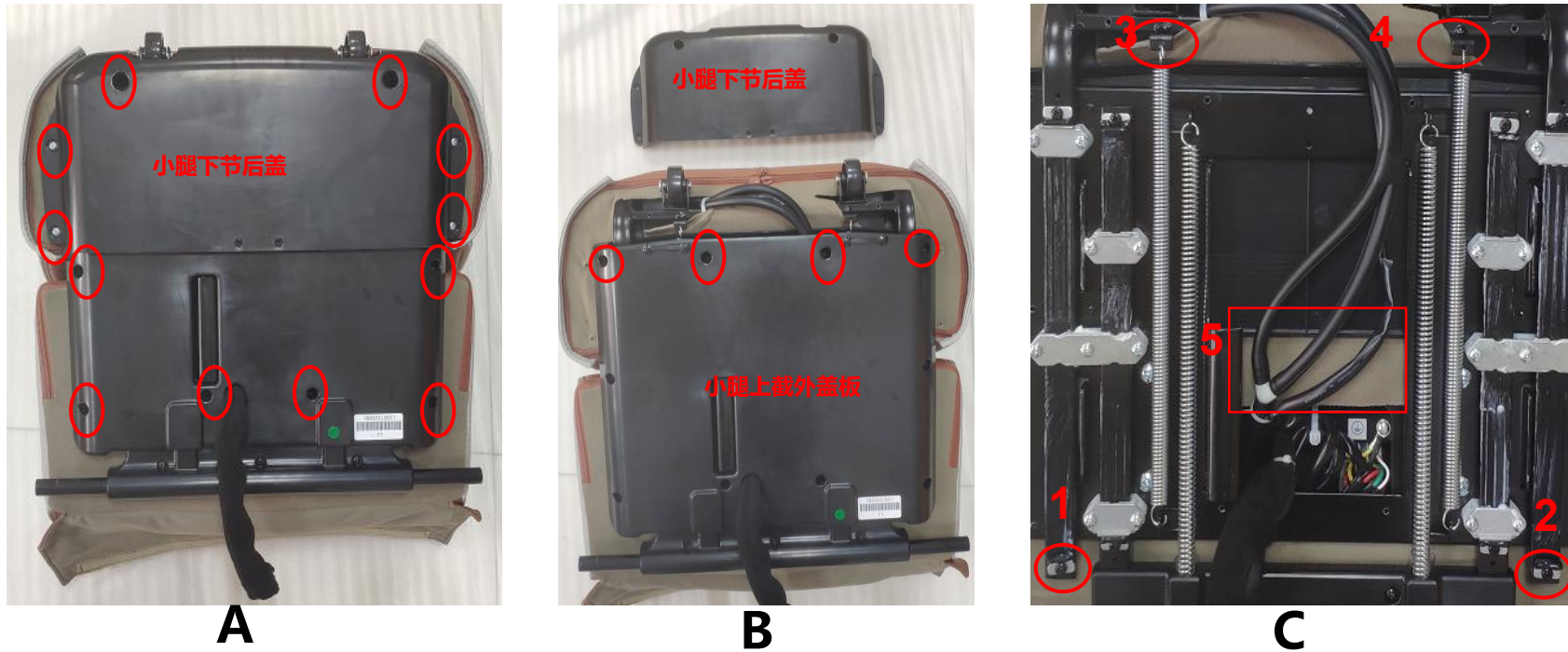

A. Remove the 12 screws shown in Figure A to take off the lower cover of the lower leg section.

B. Remove the 4 screws shown in Figure B to take off the outer cover plate of the upper section of the lower leg.

C. Remove the screws at positions 1 and 2, as well as the springs at positions 3 and 4 shown in Figure C, and then remove the air tube and connector at position 5.

4.19、 Schematic Diagram of Foot Roller Motor Disassembly

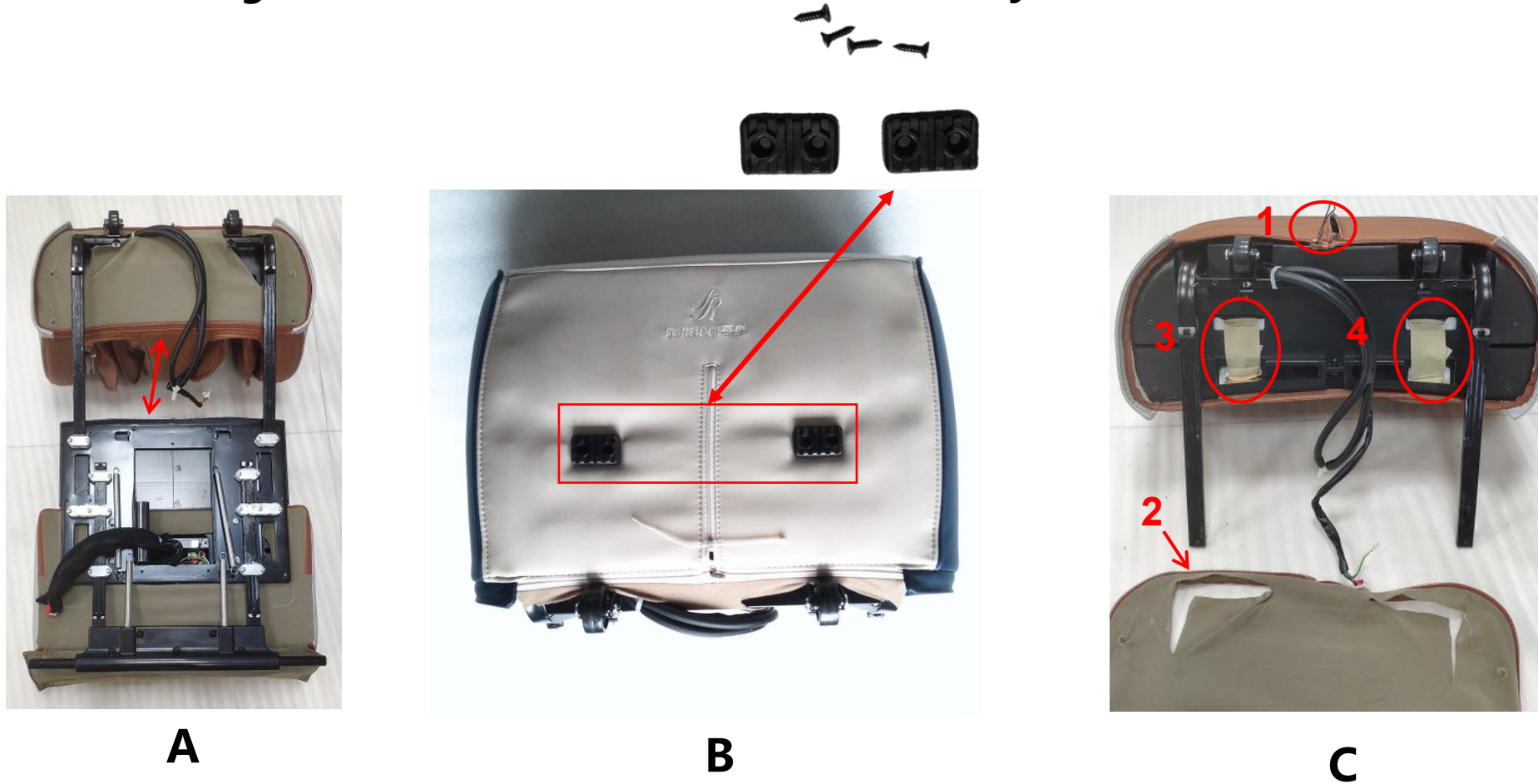

A. Remove the upper and lower leg massage assemblies as shown in Figure A.

B. Remove the 4 screws shown in Figure B to take off the footrest plastic part of the lower leg.

C. Unzip the zipper shown in Figure C to remove the velvet cloth and the Velcro at positions 3 and

4.20、 Schematic Diagram of Foot Roller Motor Disassembly



A



B



C

A. Remove the left and right zippers shown on/in Figure A.

B. Remove the four screws as Figure B.

C. Detach the calf cover as shown in Figure C.

4.21、 Schematic Diagram of Foot Roller Motor Disassembly



A

A. Remove the tape at position 1 and the zip ties at position 2 shown in Figure A.

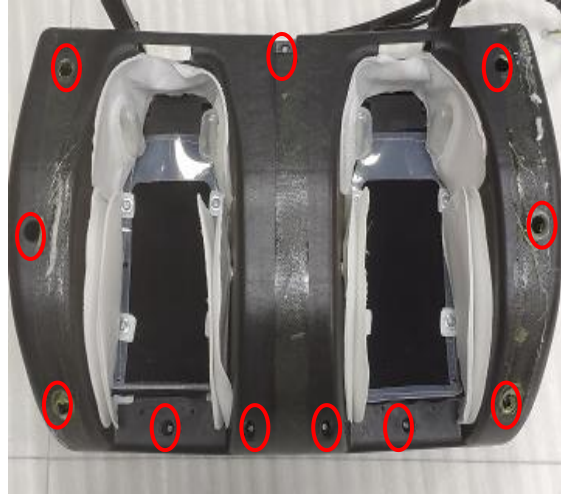

B

B. Remove the 11 screws shown in Figure B.

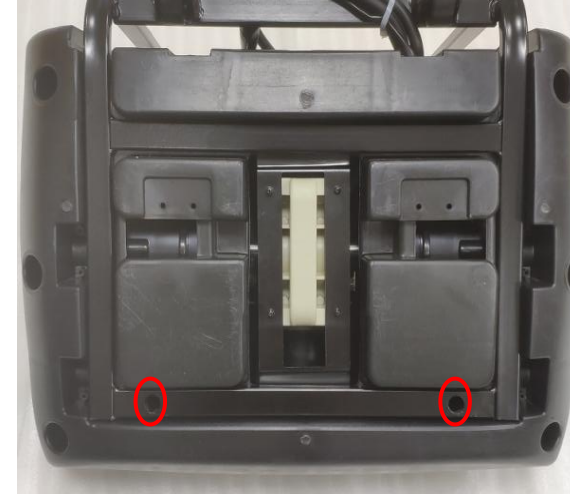

C

C. Remove the screw at position 2 shown in Figure C to separate the upper and lower plastic parts of the footrest base.

4.22、 Schematic Diagram of Foot Roller Motor Disassembly

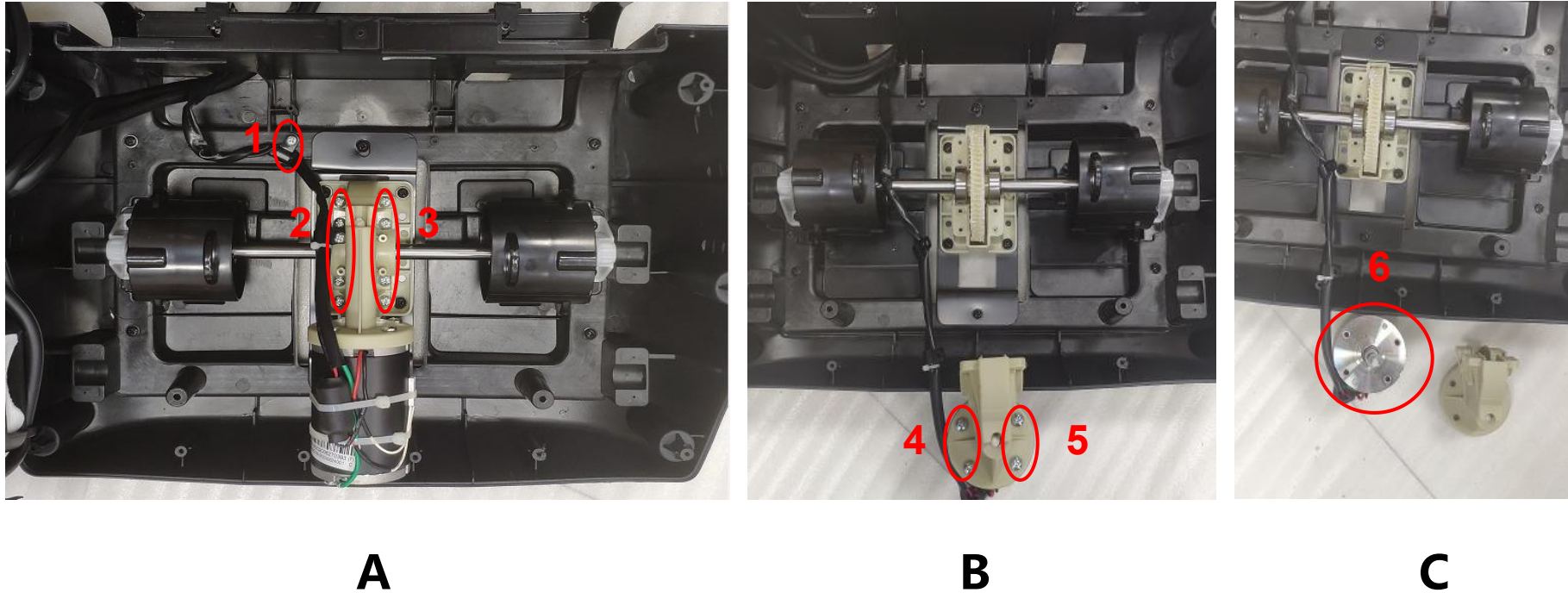

- A. Remove the screws at positions 1, 2, and 3 shown in Figure A to separate the wheel assembly.
- B. Remove the 4 screws shown in Figure B.
- C. The foot roller motor can be removed as shown in Figure C.

Fault Codes (LC Mode Entry Method: Combination Key: Press Lower Leg Down + Recline + Zero Gravity 1)

Code	Fault	Possible Causes	Troubleshooting Methods
E0	Communication error between mechanical hand and main board	1. J31 mechanical hand failure.	Check the mechanical hand drive board, drive board, wiring, and connectors for looseness and replace related components if necessary.
FB	Mechanical hand limit switch detected simultaneously	1. Upper and lower limit switch wires are not properly connected.	Check the magnet holder, magnet, and travel detection board connectors for looseness and replace related components if necessary.
FC FD	Upper travel position not detected Lower travel position not detected	1. Upper and lower position signal wires are not properly connected.	Check the circle detection board, travel motor, mechanical hand drive board drive circuit, and associated connectors for looseness and replace related components if necessary.
B1	Communication error of quick keys on armrest	1. Quick key board failure.	Check the key board, drive board, and connectors for looseness and replace related components if necessary.
F9	Overload or short circuit in travel motor drive circuit	1. Travel motor drive circuit issues.	Check the circle detection board, travel motor, mechanical hand drive board drive circuit, and associated connectors for looseness and replace related components if necessary.
FE	Shoulder position detection signal not detected	1. Shoulder position detection slot-type optocoupler is damaged.	Check the shoulder detection board, connectors, and mechanical hand drive board for looseness and replace related components if necessary.
F6~F8	Kneading width detection signal not detected	1. Kneading width detection photoelectric pair 1/2 is damaged.	Check the width detection board, kneading motor, mechanical hand drive board drive circuit, and associated connectors for looseness and replace related components if necessary.

Code	Fault Description	Possible Causes	Troubleshooting Method
E0、 E1 E2、 E3	Footrest does not lift	<ol style="list-style-type: none"> 1. Travel detection Hall element damaged. 2. Motor failure. 3. Motor drive circuit issues. 4. The motor fails to work properly due to excessive load or other reasons. 5. The upper and lower limit switch wires are not properly connected. 6. The upper and lower limit switches are damaged (one or two). 	Replace the electric cylinder of the lower leg, the drive board, and inspect the connection plug-in and wiring harness of the electric cylinder
E4、 E5 E6、 E7	Backrest does not lift	<ol style="list-style-type: none"> 1. Circle detection Hall element damaged. 2. Motor failure. 3. Motor drive circuit issues. 4. The motor fails to work properly due to excessive load or other reasons. 	Replace the backrest electric cylinder and drive board, and check whether the wiring harness and plug-in of the backrest electric cylinder are properly connected
FA、 F5	Tapping motor has problem	<ol style="list-style-type: none"> 1. There is a problem with the motor drive circuit. 2. The tapping motor malfunctioned, causing excessive current. 3. Excessive current is caused by motor blockage due to overloading or other reasons. 	Check whether the width detection board, the tapping motor, the drive circuit of the massage hand drive board and the related plug-ins are loose and in good condition, and replace the relevant accessories
F0~F4	stretch motor has problem	<ol style="list-style-type: none"> 1. Problems with the drive circuit of the telescopic motor. 2. The telescopic motor malfunctioned, causing excessive current. 3. The detection plate for the number of turns that can be extended or retracted is damaged. 4. Check if the magnet for the telescopic detection has fallen off. 	Check whether the stretch detection board, stretch motor, stretch upper and lower magnets, the drive circuit of the mechanical hand drive board and related plug-ins are loose and in good condition, and replace the relevant parts

Code	Fault Description	Possible Causes	Troubleshooting Method
B7	Foot roller motor does not work	<ol style="list-style-type: none"> 1. Foot roller motor drive circuit issue. 2. The foot roller motor malfunctioned, causing excessive current. 3. Excessive current is caused by motor blockage due to excessive load or other reasons. 	Check the calf junction board motor connector, drive board connector, harness, and motor for looseness and replace related components.
B2 B4	Backrest heating does not work	<ol style="list-style-type: none"> 1. Backrest heating drive circuit issue. 2. Overload or short circuit of the backrest heating 3. Fault in the mainboard heating circuit 4. The heater is open-circuited, the plug-in is loose or the wire is broken 	Check the drive board, backrest pad, heating wire connector, and harness for looseness and replace related components.
B8	Air pump does not work	<ol style="list-style-type: none"> 1. Air pump drive circuit issue. 2. The air pump malfunctions, causing excessive current. 3. Excessive current occurs when the air pump is blocked due to overloading or other reasons. 	Check the drive board and air pump for looseness and replace related components.
BB BC	Calf heating does not work	<ol style="list-style-type: none"> 1. Calf heating drive circuit issue. 2. Overload or short circuit of the calf heating 3. Fault in the mainboard heating circuit 4. The heater is open-circuited, the plug-in is loose or the wire is broken 	Check the calf junction board connector, drive board connector, harness, and heating wire for looseness and replace related components.

1. Whole machine does not work
2. Kneading does not work
3. Tapping does not work
4. Massage hand can not move up or down
5. Stretch function does not work
6. Foot roller does not work
7. Backrest electric cylinder does not work
8. Calf electric cylinder does not work
9. Back heat therapy does not work
10. A group of airbags does not work
11. Bluetooth MP3 does not work
12. Armrest LED light does not turn on
13. USB power does not charge
14. Smart voice control does not work



5.1 、 Whole Machine Does Not Work



1

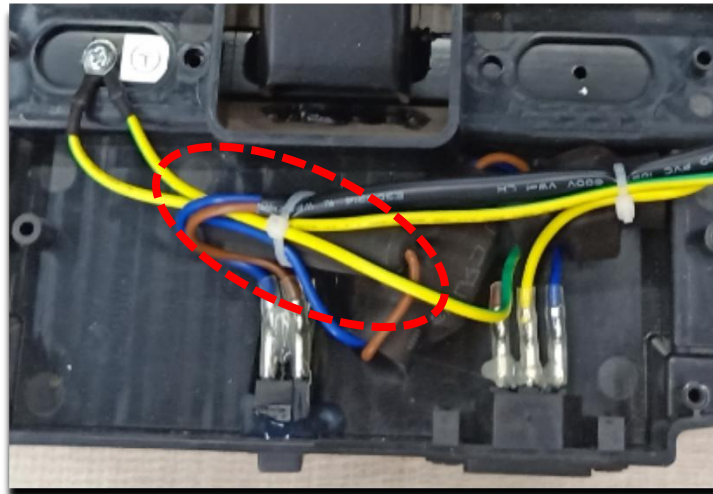

2

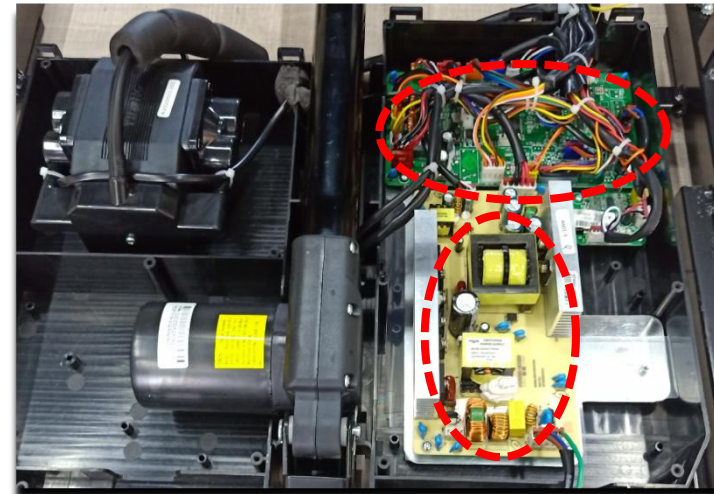

3

Fault Judgment and Maintenance:

A. The remote controller is damaged, so the chair cannot turning on. Use the substitution method to solve the problem (Figure 1).

B. The fuse has blown, typically caused by a short circuit in the drive board due to an overload. Identify and remove the short-circuit load, inspect the drive board, and replace the fuse (Figure 2).

C. Check if the power supply board outputs 24V/5VA voltage is ok. If not, the power supply board is broken(Figure 3). If the voltage output is normal, it indicates that the power supply is ok, and the issue lies with the drive board, which need to be replaced.

Note: The 5VA voltage is present as soon as the massage chair is powered on.

5.2 、 Kneading Motor Does Not Work

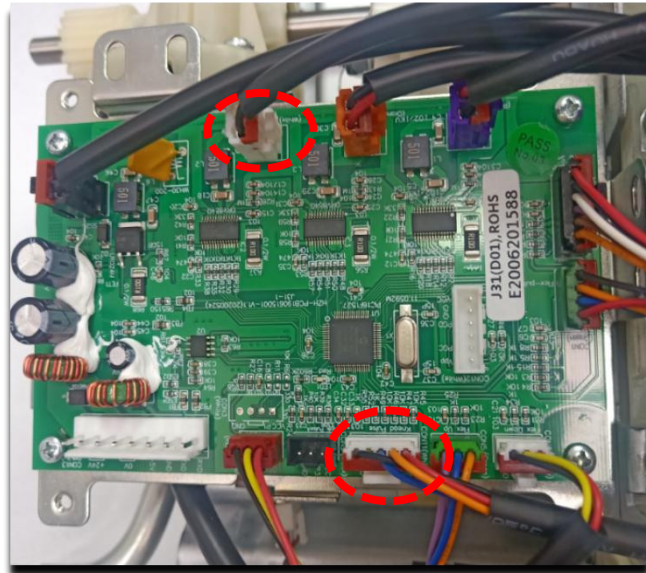

1

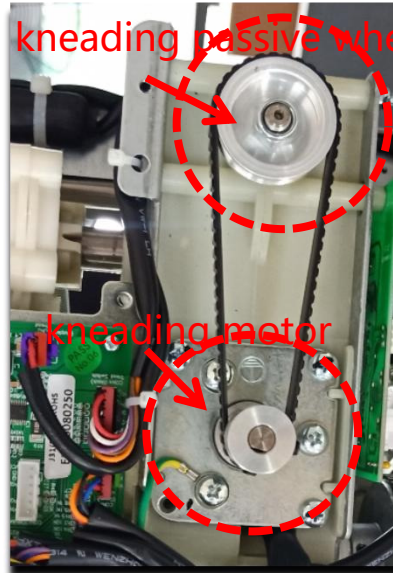

2

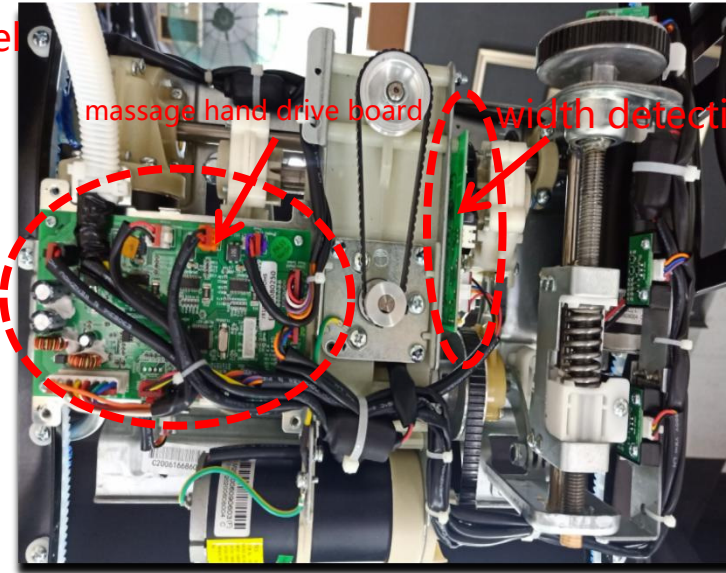

3

Fault Judgment and Maintenance:

- A. First, check whether there is poor contact or connector detachment in the mechanical hand drive board harness (Figure 1).
- B. Check if the motor is damaged. You can use the power supply of the tapping motor to judge the condition of the motor (Figure 2). Replace the kneading motor.
- C. Check if the width detection board is damaged (Figure 3). Replace the width detection board.
- D. Use the substitution method to check if the drive board is damaged (Figure 3). Replace the massage hand drive board.
- E. Manually rotate the kneading passive wheel to see if it feels very tight. If so, replace the kneading worm gear box assembly (Figure 2). Replace the kneading worm gear box.

5.3 、 Tapping Motor Does Not Work

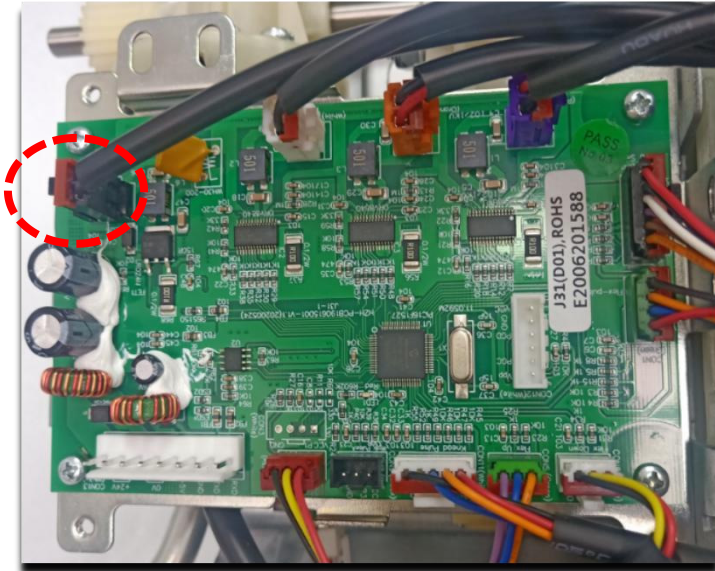

1

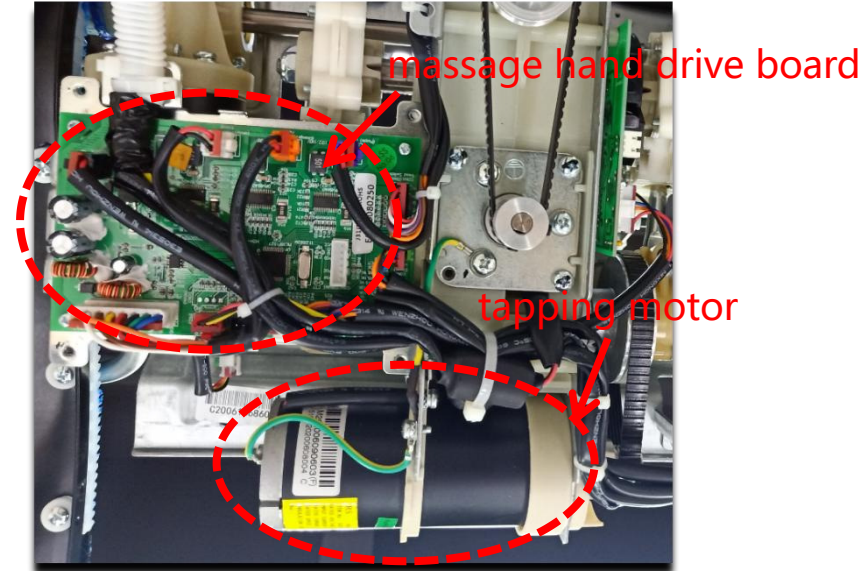

2

Fault Judgment and Maintenance:

A. First, check whether there is poor contact or connector detachment in the message hand drive board harness (Figure 1).

B. Check if the motor is damaged. You can use the power supply of the kneading motor to judge the condition of the motor (Figure 2). Replace the tapping motor.

C. Use the substitution method to check if the drive board is damaged (Figure 2). Replace the message hand drive board.

5.4、 Massage Hand Cannot Move Up or Down

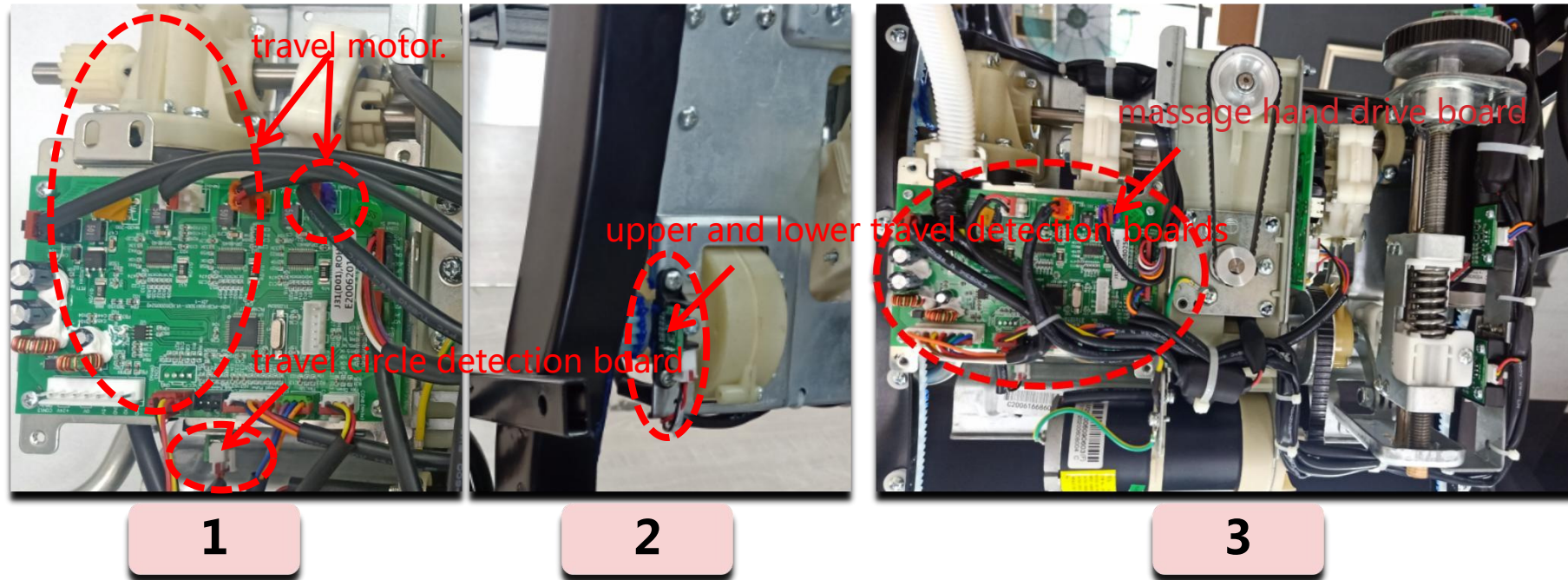

Fault Judgment and Maintenance:

- A. First, check whether there is poor contact or connector detachment in the message hand drive board harness (Figure 1).
- B. Check if the motor is damaged. You can use the power supply of the tapping motor to judge the condition of the motor (Figure 1). Replace the travel motor.
- C. Check if the travel circle detection board is damaged (Figure 1). Replace the travel circle detection board.
- D. Check if the upper and lower travel detection boards are damaged (Figure 2). Replace the upper and lower travel detection boards.
- E. Use the substitution method to check if the drive board is damaged (Figure 3). Replace the message hand drive board.

5.5、Stretch function does not work

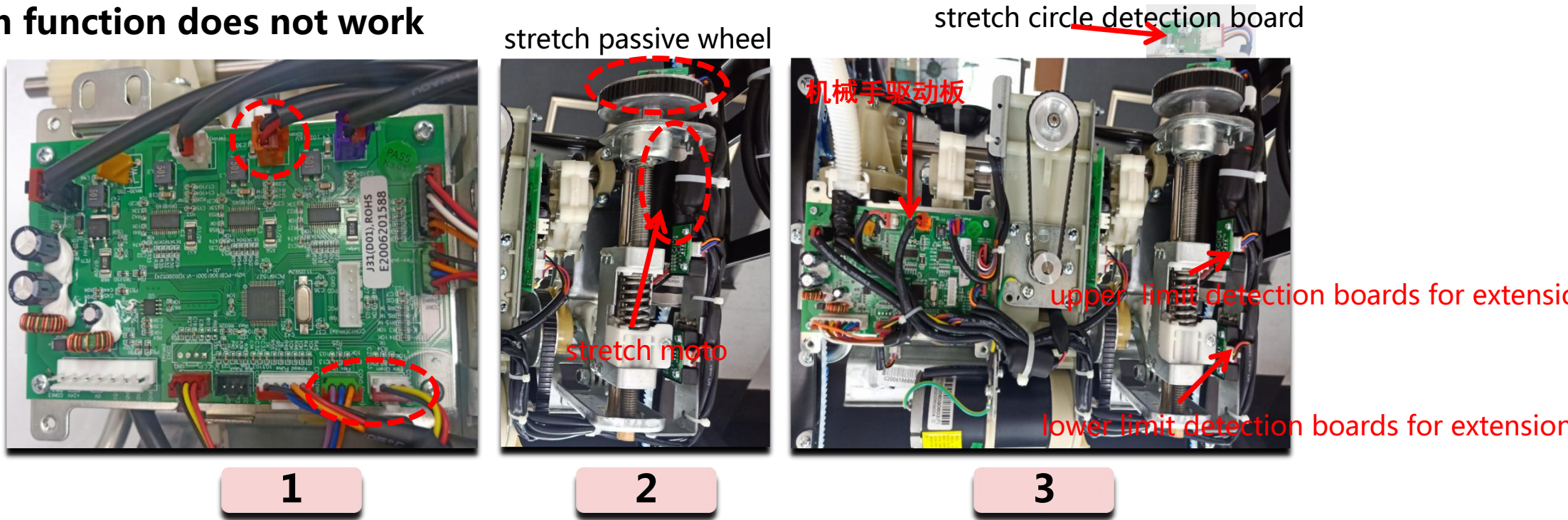

Fault Judgment and Maintenance:

- A. First, check whether there is poor contact or connector detachment in the massage hand drive board harness (Figure 1).
- B. Check if the motor is damaged. You can use the power supply of the tapping motor to judge the condition of the motor (Figure 2). Replace the stretch motor.
- C. Check if the stretch circle detection board is damaged (Figure 3). Replace the stretch circle detection board.
- D. Check if the upper and lower limit detection boards for extension are damaged (Figure 3). Replace the upper and lower limit detection boards for extension.
- E. Use the substitution method to check if the drive board is damaged (Figure 3). Replace the massage hand drive board.
- F. Manually rotate the stretch passive wheel to see if there are any abnormalities. If abnormalities are found, replace the stretch mechanism assembly (Figure 2).

5.6、 Foot roller does not work

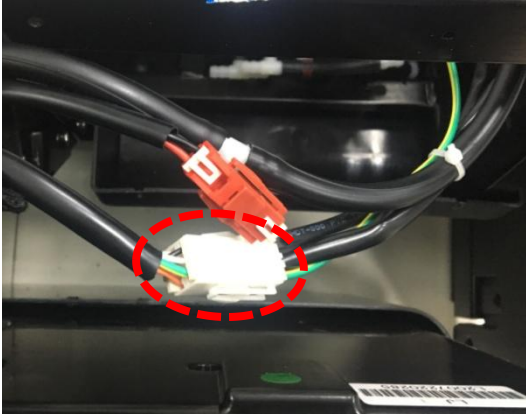

1

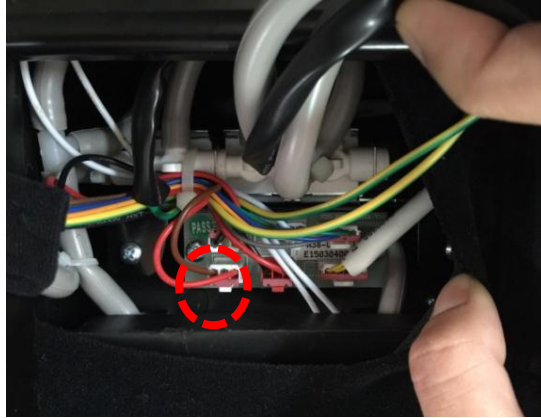

2

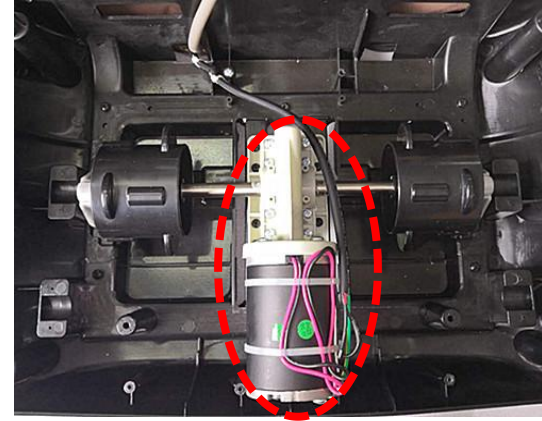

3

Fault Judgment and Maintenance:

A. First, check whether the connector of the calf harness has fallen off (Figure 1).

B. Use a multimeter to measure the red and black wires of the connector (Figure 1) to see if there is a DC24V voltage. If there is no voltage, it indicates that the drive board and harness are damaged. If there is voltage, it proves that there is a fault inside the calf.

C. Disassemble the calf to check whether the connector of the junction board has fallen off. If it has fallen off, simply reinsert it (Figure 2).

D. If the connector of the calf junction board is intact, it is determined that the calf motor is damaged and needs to be replaced (Figure 3).

Main Causes of Foot Roller Motor Failure:

Connector of the harness

Foot roller motor

Drive board

5.7、 Backrest electric cylinder does not work

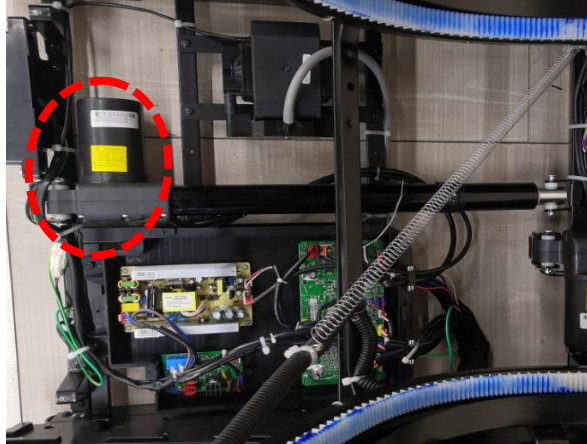

1

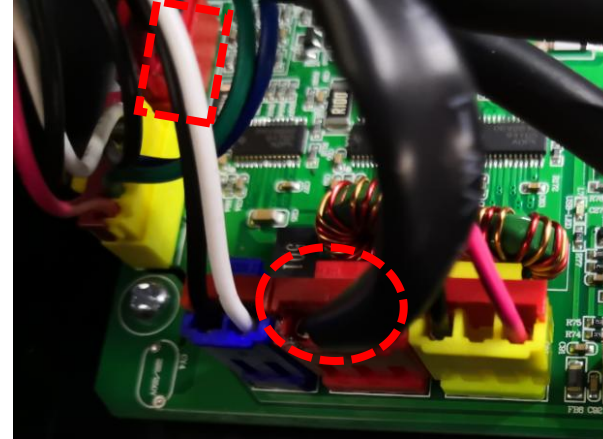

2

Fault Judgment and Maintenance:

- A. First, press and hold the electric cylinder control button, and listen, it sounds “beep, beep,” followed by two “drip” sounds when released. This indicates that the electric cylinder signal has not been detected, suggesting that the electric cylinder or the drive board may be faulty. A substitution test can be performed to determine the exact issue.
- B. Swap the connector of the non-working electric cylinder with another good working electric cylinder (Note: from the main board end). If it still does not work after the swap, it indicates that the electric cylinder is damaged and needs to be replaced. If it works after the swap, it indicates that the main board is broken and need to replace a new one.

Main Causes of Backrest Electric Cylinder Failure:

Backrest electric cylinder

Drive board

Wiring harness

5.8、 Calf electric cylinder does not work



1

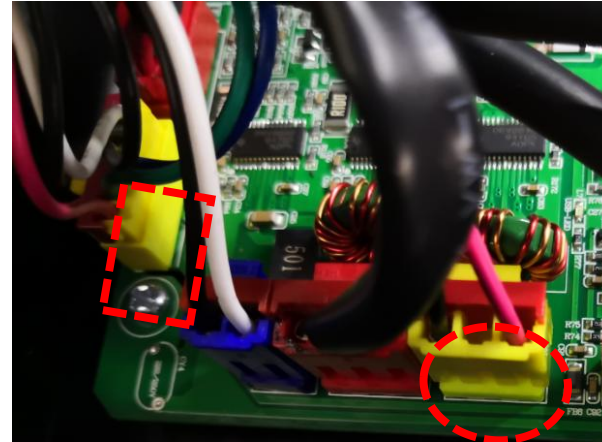

2

Fault Judgment and Maintenance:

A. First, press and hold the electric cylinder control button, and listen, it sounds “beep, beep,” followed by two “drip” sounds when released. This indicates that the electric cylinder signal has not been detected, suggesting that the electric cylinder or the drive board may be faulty. A substitution test can be performed to determine the exact issue.

B. Swap the connector of the non-working electric cylinder with another good working electric cylinder (Note: from the main board end). If it still does not work after the swap, it indicates that the electric cylinder is damaged and needs to be replaced. If it works after the swap, it indicates that the main board is broken and need to replace a new one.

Main Causes of Calf Electric Cylinder Failure:

Calf electric cylinder

Drive board

Wiring harness

5.9、 Back heat therapy does not work



1



2



3



4

Fault Judgment and Maintenance:

A. Check whether there is poor contact or detachment in the connector of the back heat therapy wire (Figure 1).

B. Use a multimeter to measure whether there is an AC24V voltage in the yellow plug P6 of the drive board and the corresponding plug of the backrest pad. If there is no voltage, the drive board is damaged and needs to be replaced (Figure 3).

C. You can also use a multimeter to measure the resistance of the back heating wire as shown in Figure 2. If there is resistance, it indicates a problem with the drive circuit. If there is no resistance, replace the back heating wire (Figure 4).

Main Causes of Back Heat Therapy Failure:

Backrest heating wire

Drive board

Wiring harness

5.10、 A group of airbags does not work

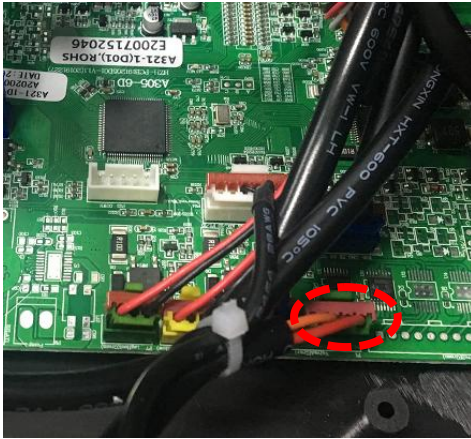

1



2



3

Fault Judgment and Maintenance:

A. Check whether the airbag in this circuit is broken or if there are any kinks in the air hose (Figure 2, Figure 3). Visual inspection is recommended, as this is highly probable!

B. The solenoid valve controlling the air pressure in this circuit is damaged (Figure 2). The probability of this being the issue is relatively low.

C. The peripheral circuit controlling the air pressure in this circuit is malfunctioning; consider replacing the drive board.

Main Causes of Airbag Failure:

Airbags broken

Kinked air hose

Solenoid valve broken

5.11、 Bluetooth MP3 does not work



1



2



3

Fault Judgment and Maintenance:

A. (Prerequisite: Bluetooth pairing with the phone) Check for poor contact in the audio Bluetooth board wiring or faulty Bluetooth MP3 board; replace it (Figure 1).

B. Check if poor contact in the connection line between the audio Bluetooth board and the speaker (Figure 2).

C. If one of the speakers is not working, inspect the wiring and replace the speaker as needed (Figure 3).

Main Causes of Bluetooth MP3 Board Failure:

Bluetooth board

Wiring harness

Drive board

5.12、 Armrest LED light does not turn on

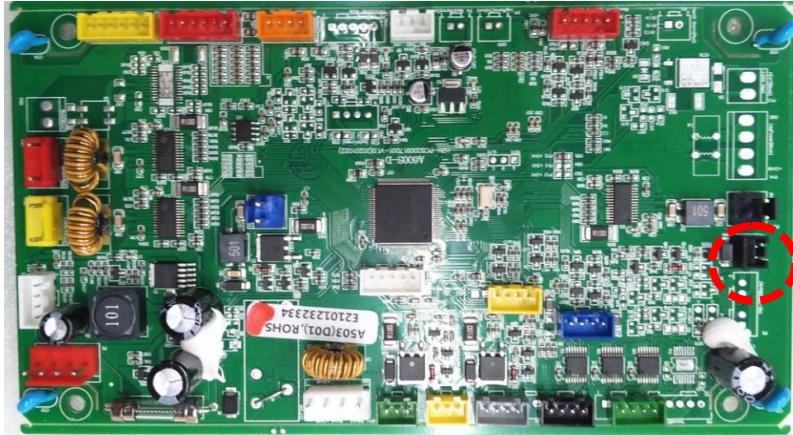

1



2



3

Fault Judgment and Maintenance:

A. Use a multimeter to measure whether there is a DC12V voltage at the P15 connector on the drive board. If there is no voltage, the drive board is faulty (Figure 1).

B. Check whether there is poor contact or detachment in the armrest wire connector (Figure 2).

C. If the LED strip is faulty, replace the armrest LED strip (Figure 3).

Main Causes of Armrest LED Failure:

Armrest LED strip

Wiring harness

Drive board

5.13、 USB power does not charge



1



2



3

Fault Judgment and Maintenance:

A. First, check whether there is any issue with the data cable of the smart device (Figure 1).

B. Check whether the USB connector inside the armrest phone slot has fallen off (Figure 2).

C. Check whether the P12 connector on the drive board has fallen off and whether there is a 5V voltage output (Figure 3).

Main Causes of USB Power Failure:

USB port

Data cable

Drive board

5.14、 Smart voice control does not work



1

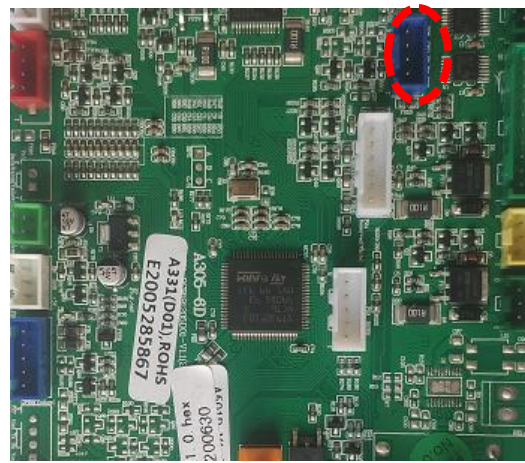

2



3

Fault Judgment and Maintenance:

- A. Activate the massage chair functions using voice commands and check if there is a voice response (Figure 1).
- B. If the voice control is not working, inspect the wiring and signal quality of the small microphone or check for damage to the smart voice control board (Figure 2 and Figure 3).

Main Causes of Smart Voice Control Failure:

- Voice control board
- Microphone (Mikrofon)
- Wiring harness
- Drive board



按摩椅 我要艾力斯特