

ROTAI
荣泰

ROTAI
荣泰

***RT-7900S* Repair Manual**

Contents

- 01 Massage Chair Control Principle
- 02 Structure Instruction & Installation
- 03 Troubleshooting

Massage Chair Control Principle

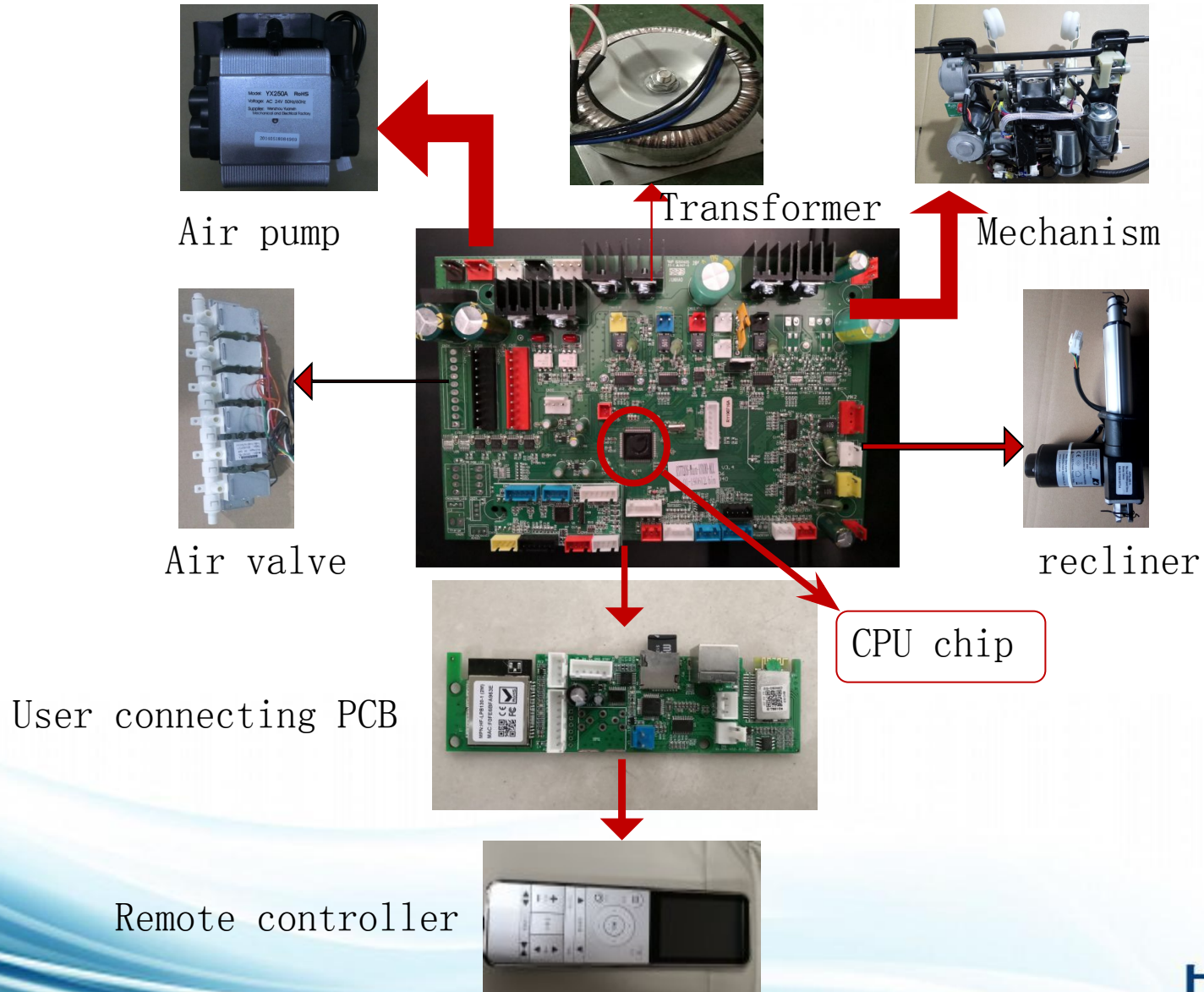

1.Inner Structure Diagram

2. Mainboard Diagram

3. Air Valve Diagram

4. Part Removal Guide and Video

RT7900S Profile



1. Inner Structure Diagram

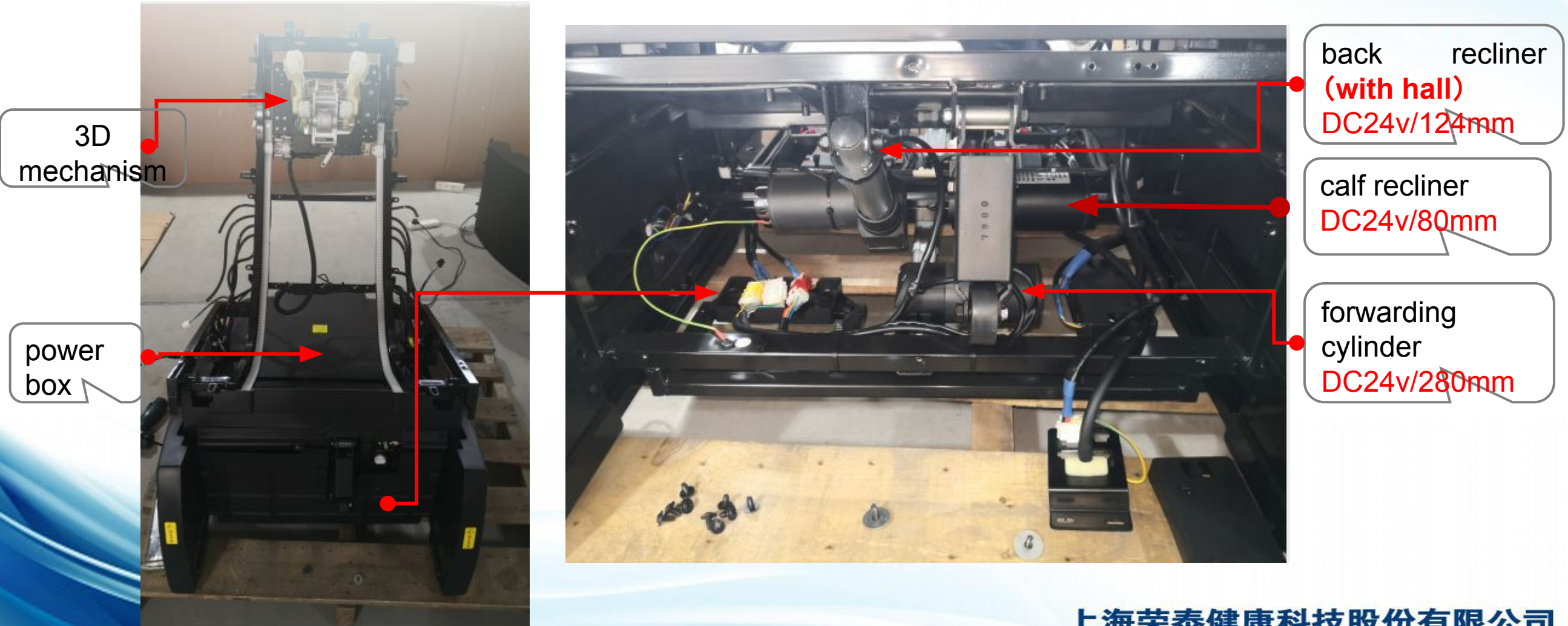

1.2 Mechanism's Structure

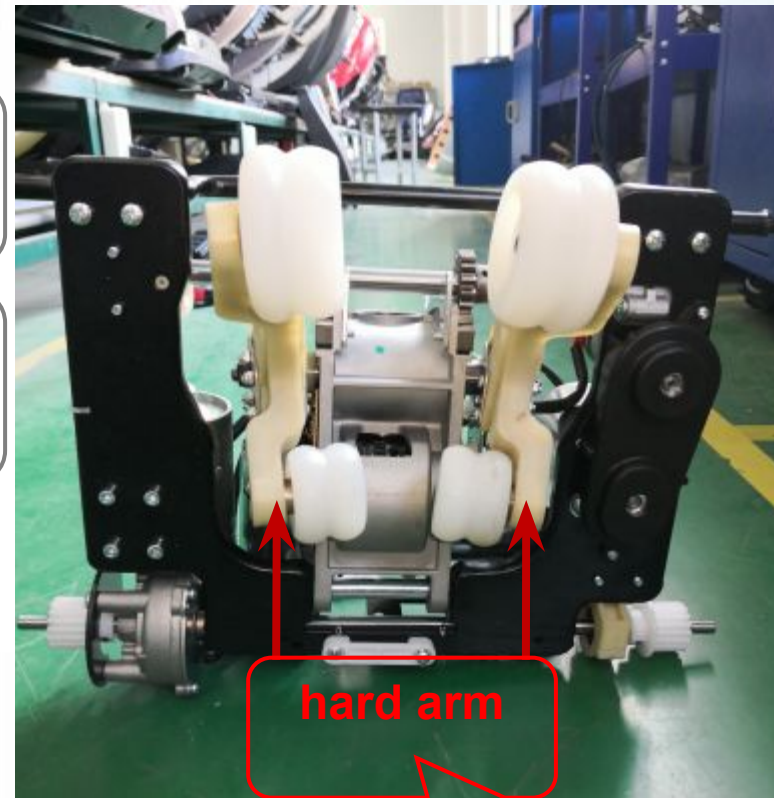
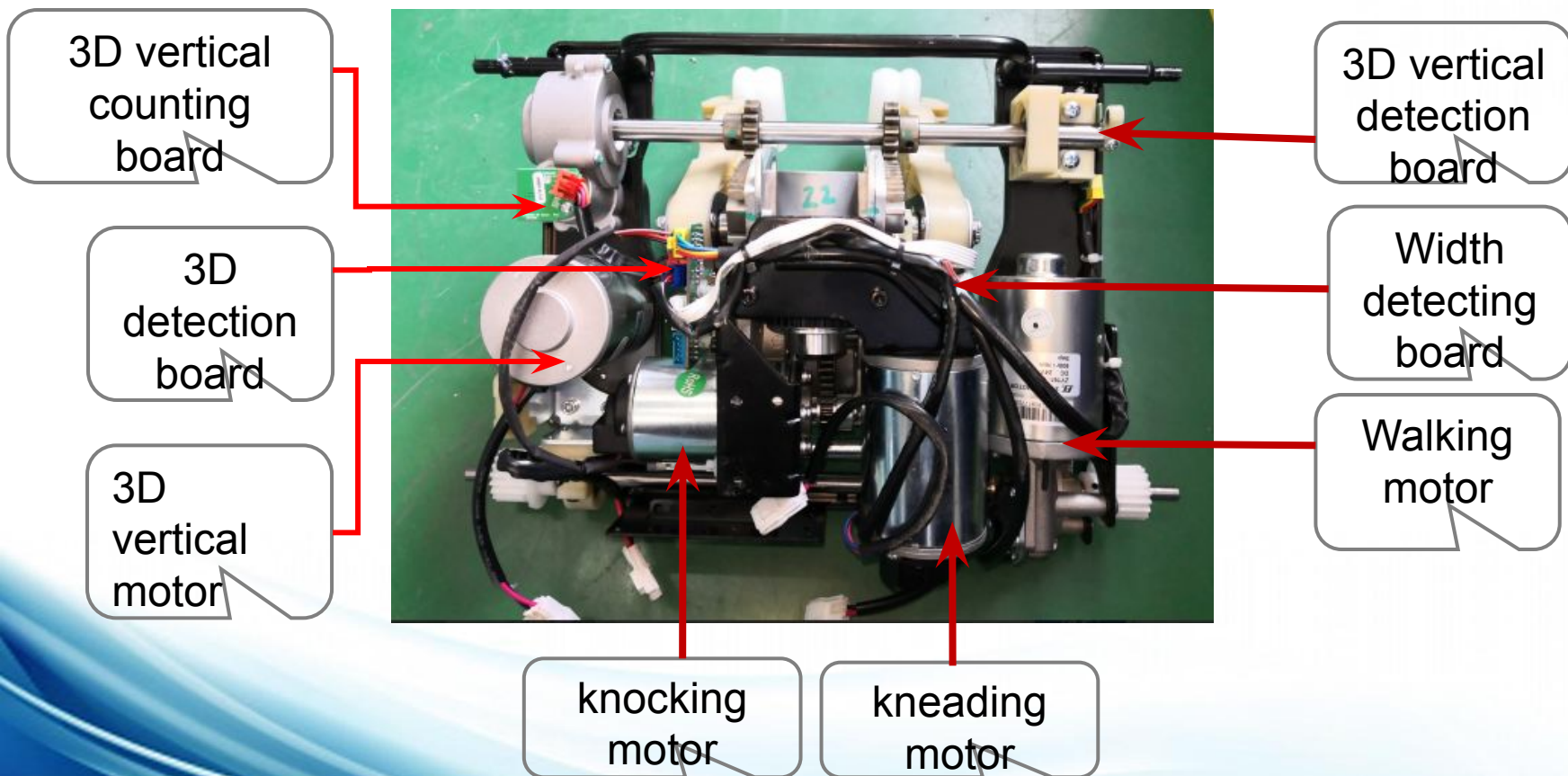

1.3 Power Box Inner Diagram

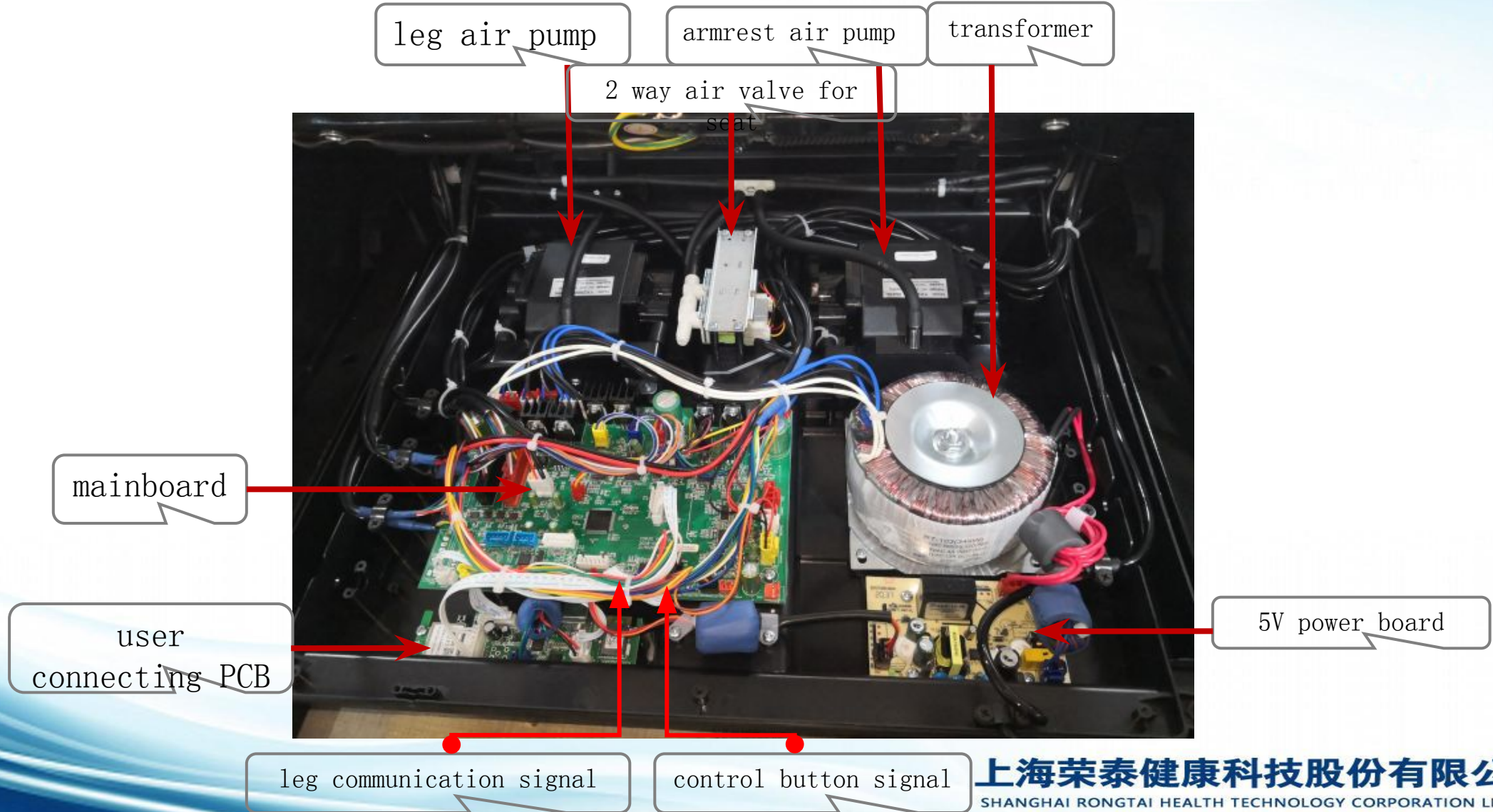

2. 1. Mainboard Diagram

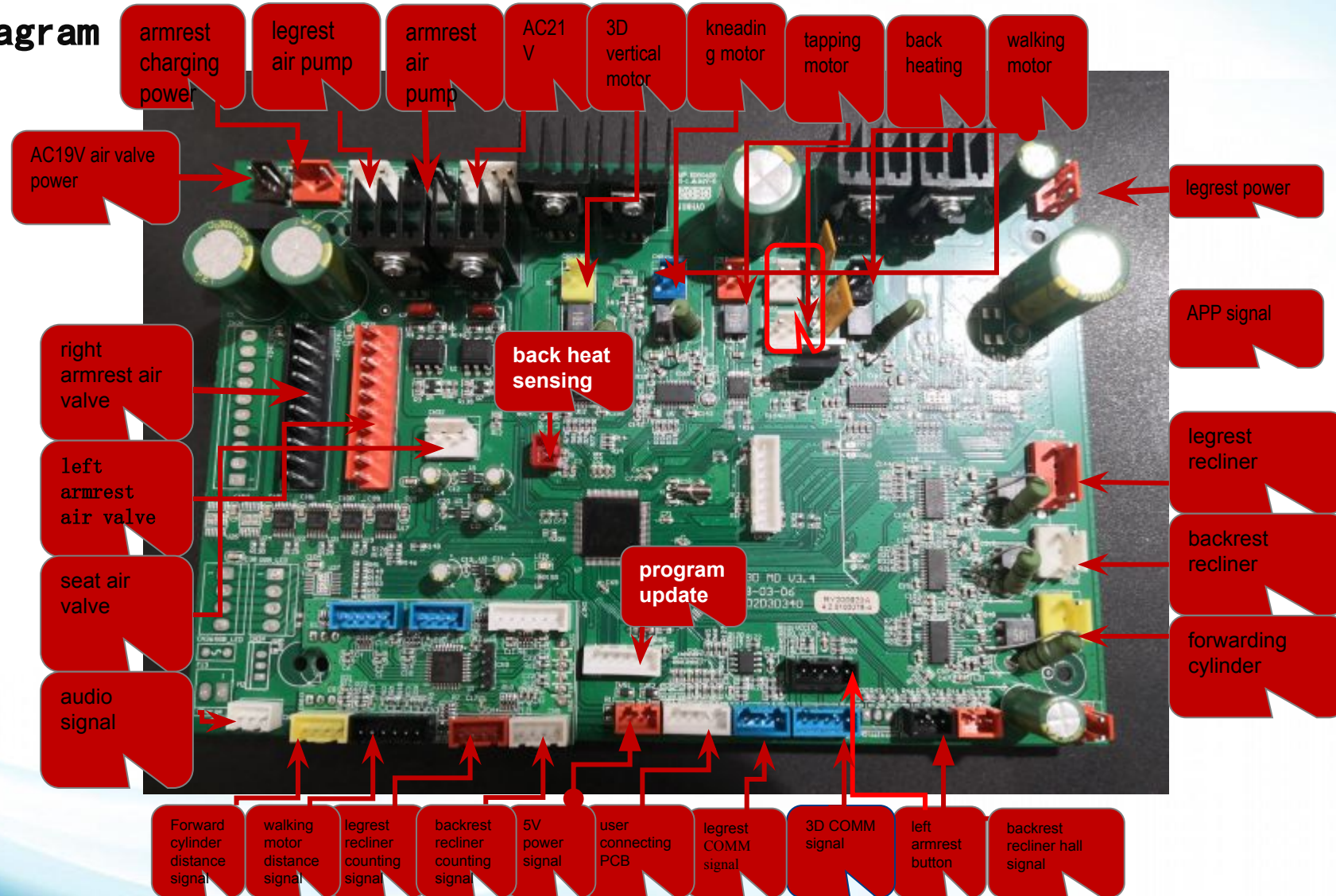

2.2 User Connecting PCB Connector Diagram

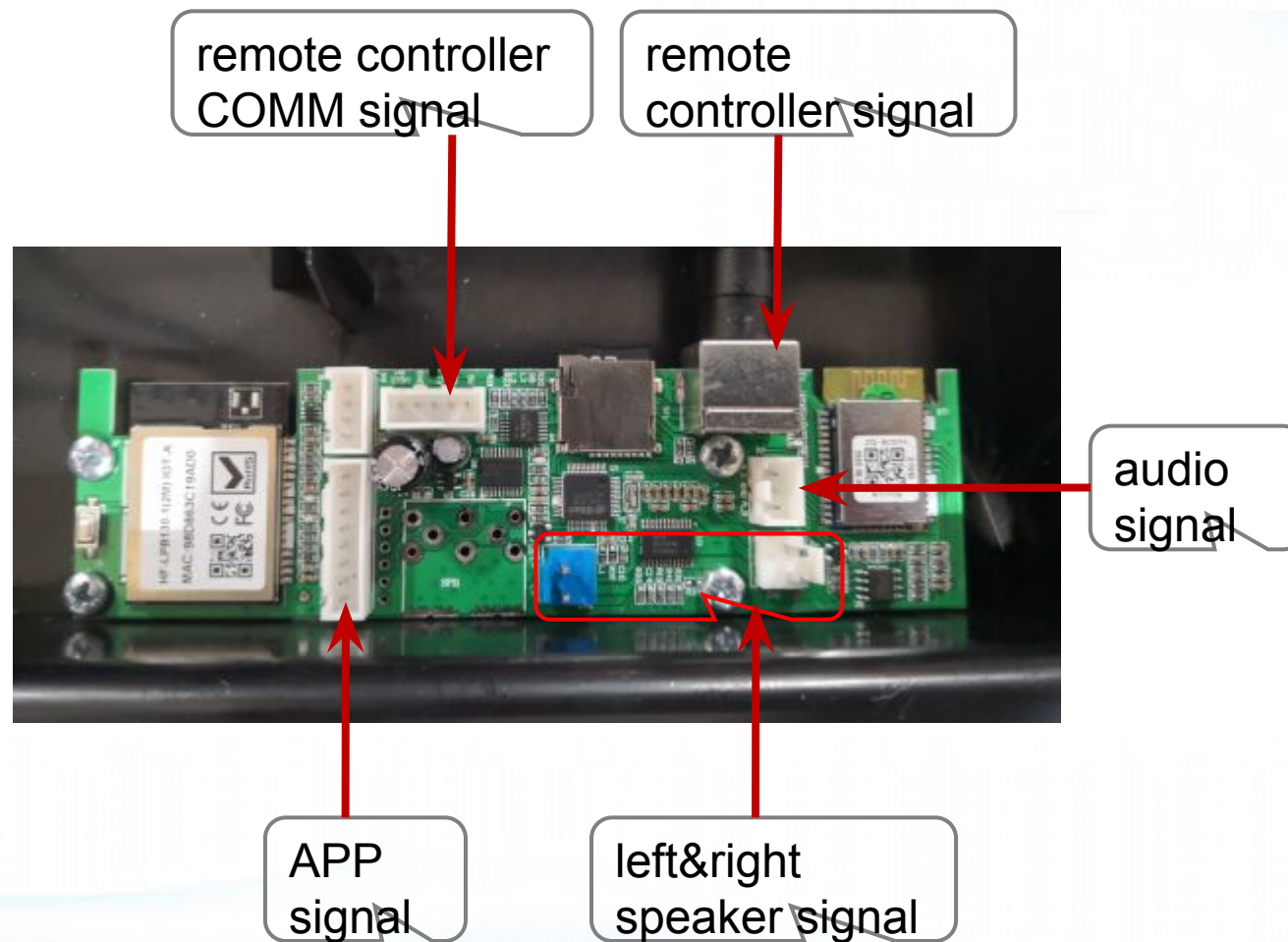

2.3 Footrest mainboard connector diagram

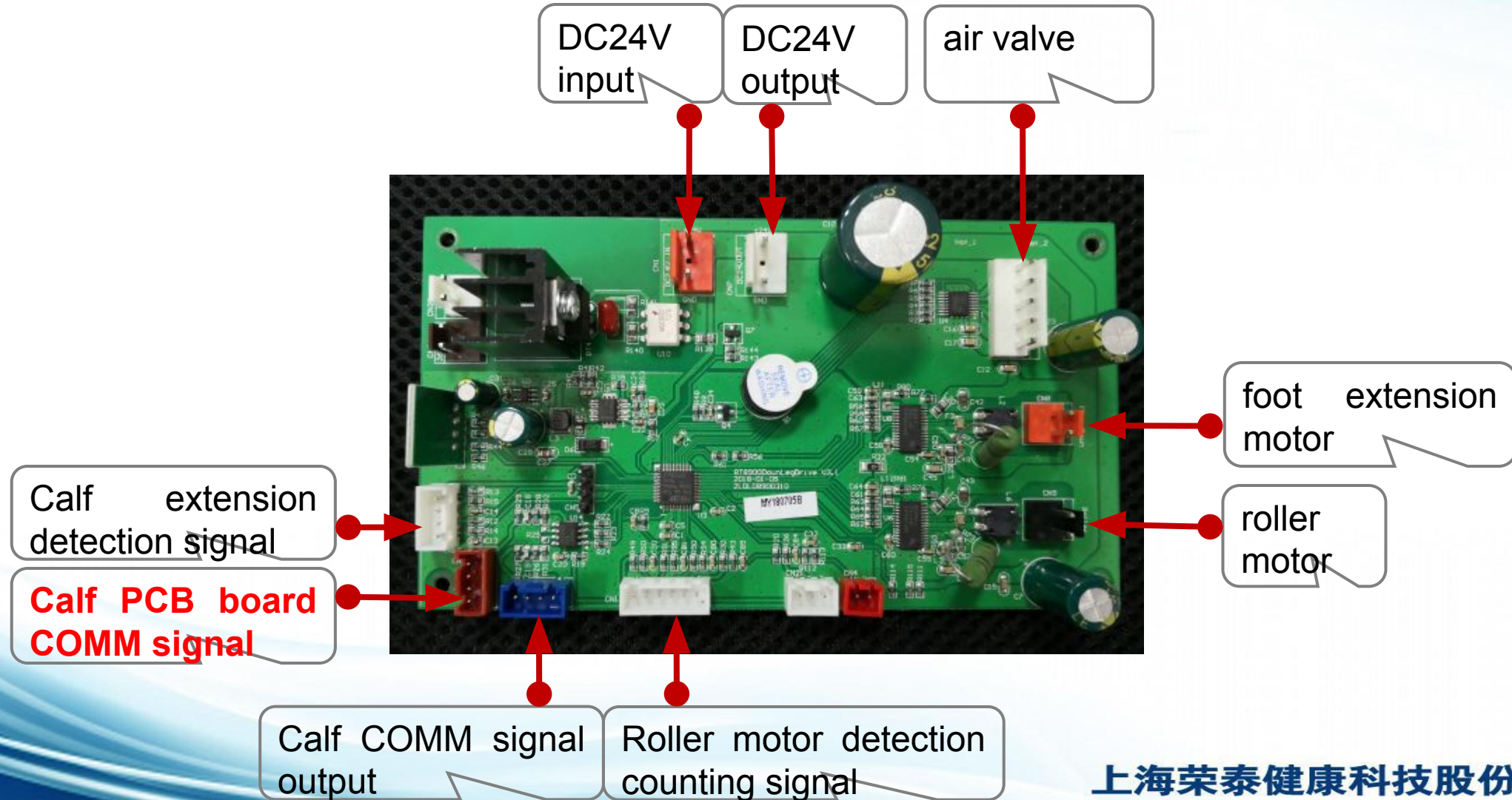

2.4 Legrest mainboard connector diagram

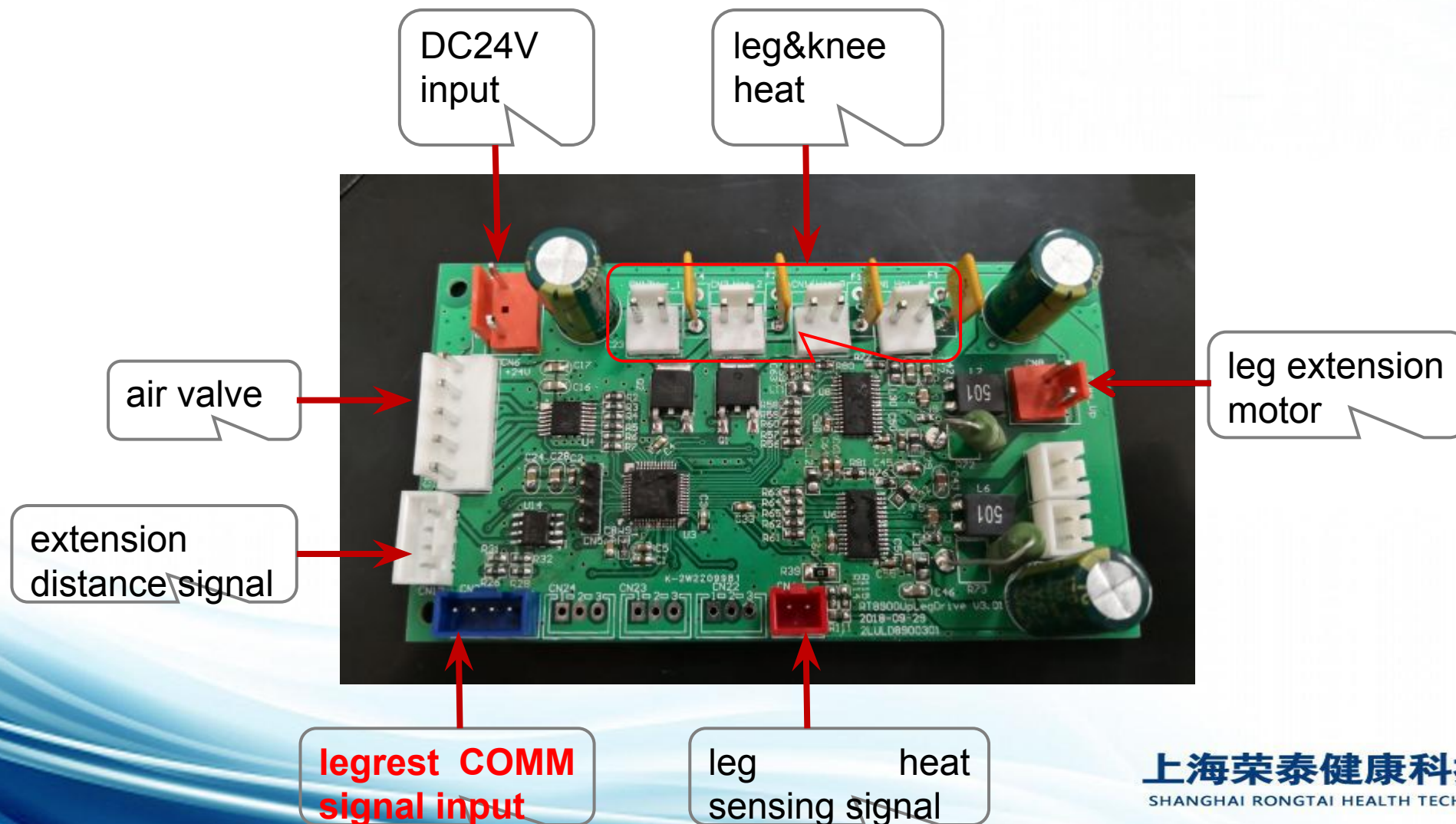

2.5 3D Interface Board Diagram

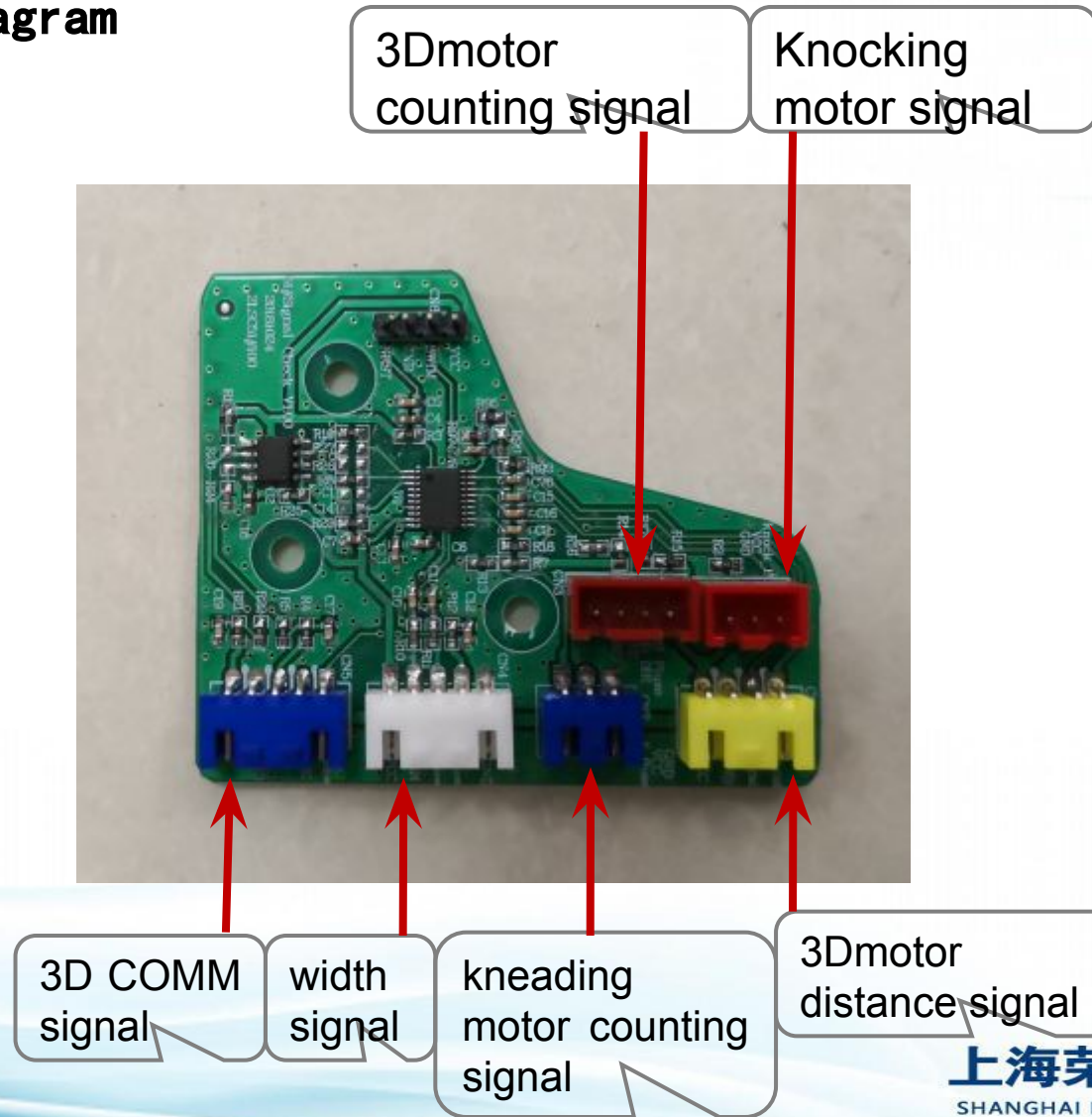

2. 6 Width sensor board diagram

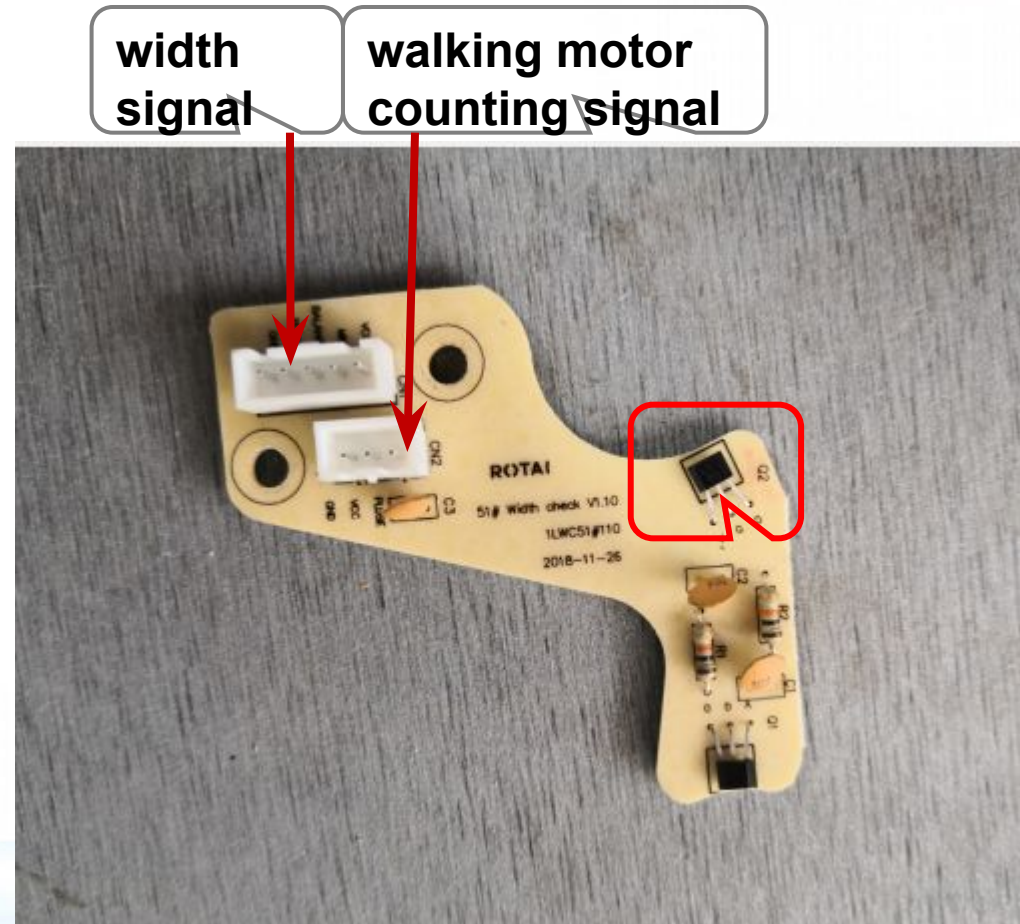

3.1 Air Valve Diagram

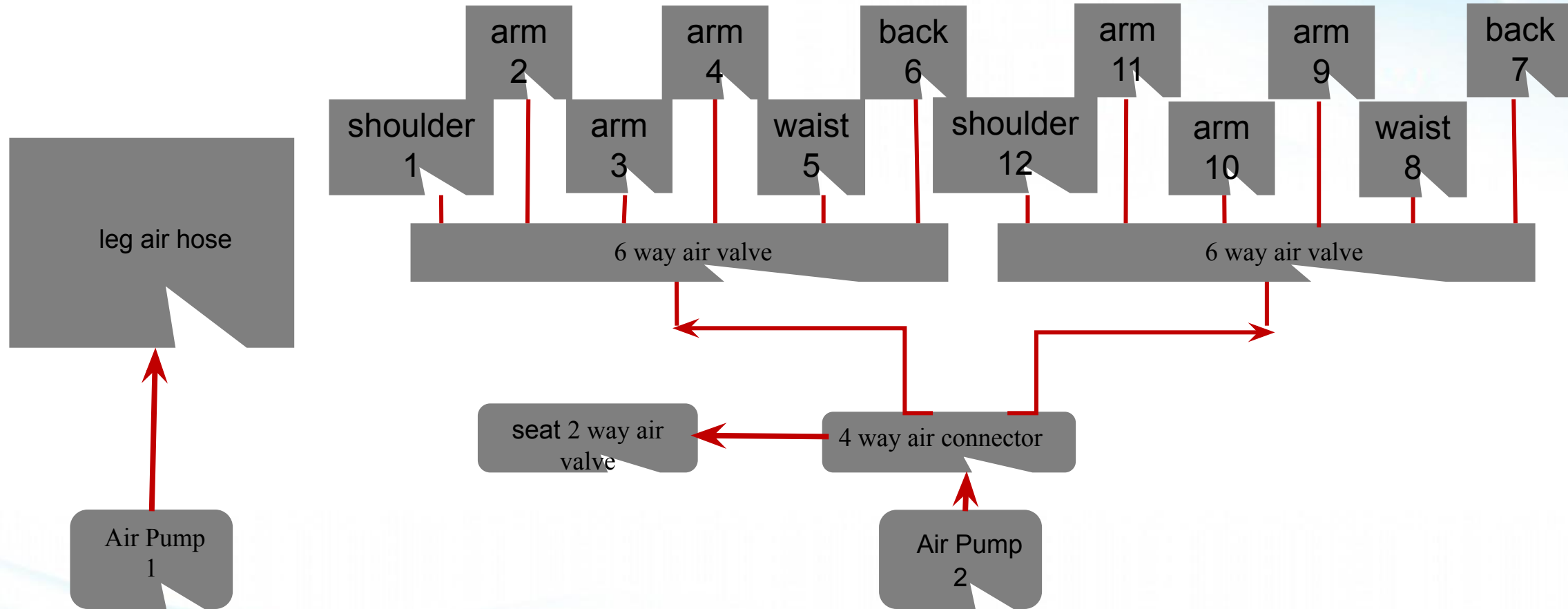

4.1 Armrest installation guide

Get the armrest unit (Same way to install the left and right arm)

1. connect the air hose and plugs according to the matching No. and colors.
2. Attach the mounting bracket to the chair seat Square steel tube.
3. Line up the armrest mounting pin with the pin receiver on the chair body.
4. Press the armrest.
5. Screw the bolts in 4/5 position.

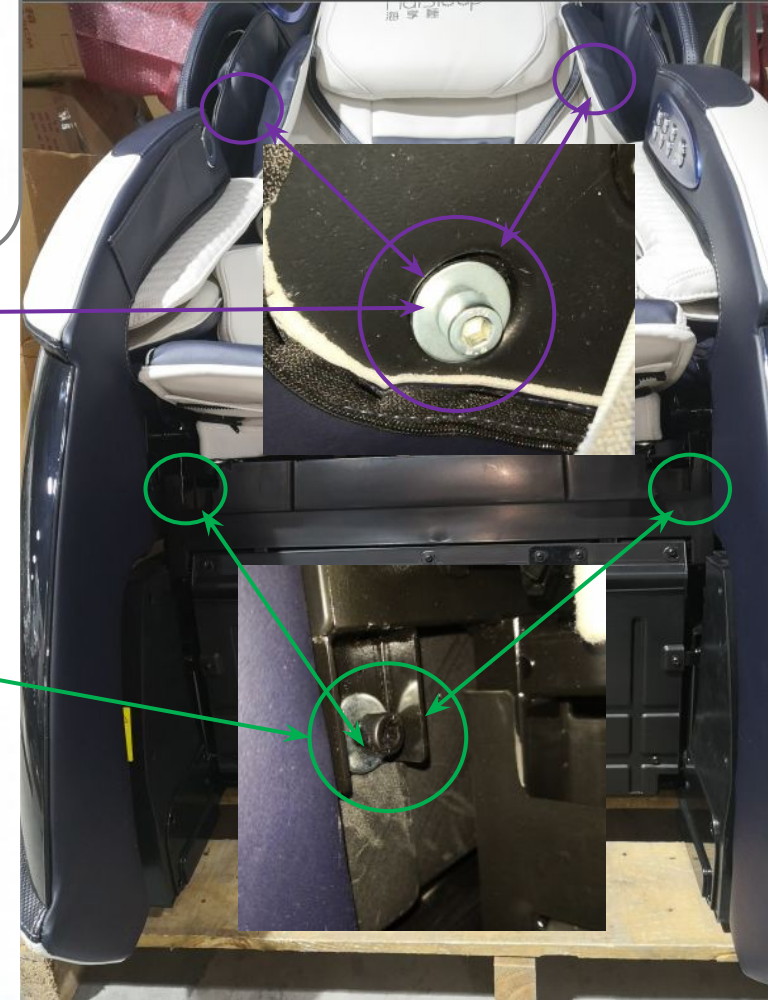
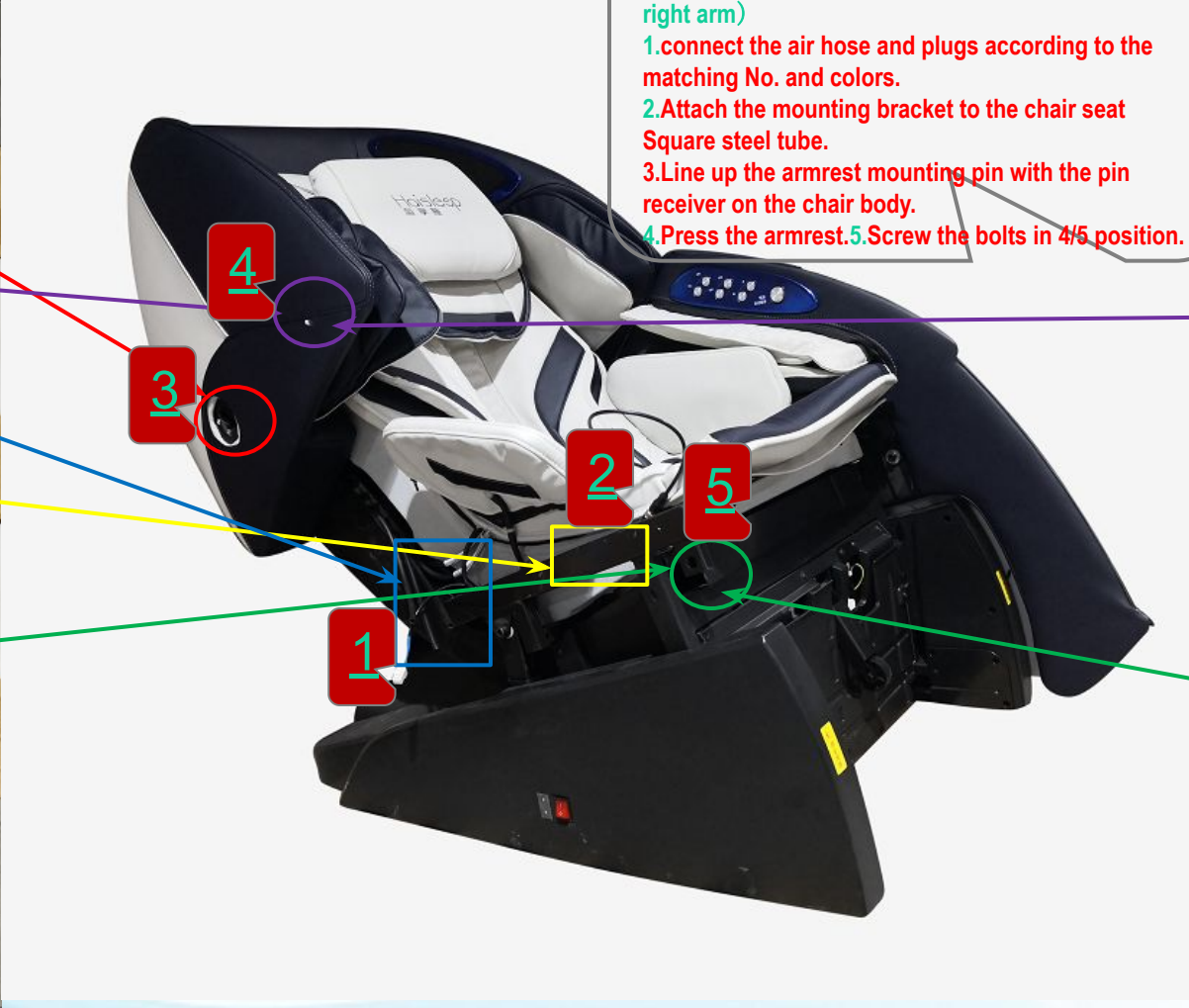
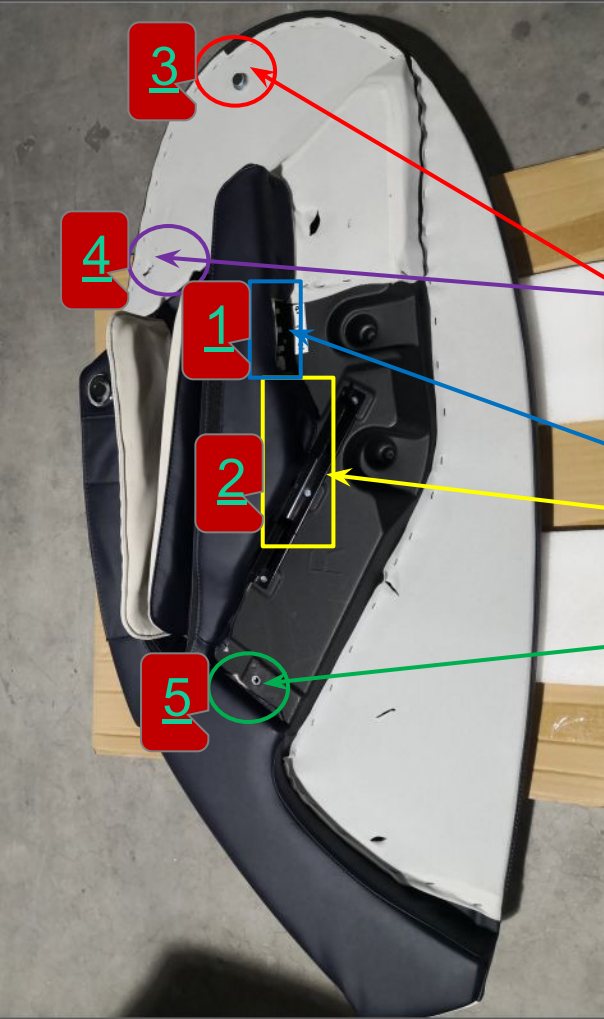

4.2 Footrest Installation Guide



1. Find this cable



2. Plug it into
chair body



3. Attach the
footrest to the
chair body



4. Attach the
footrest clip to
the end of the
chair body

4.3 Head Assembly Removal Guide

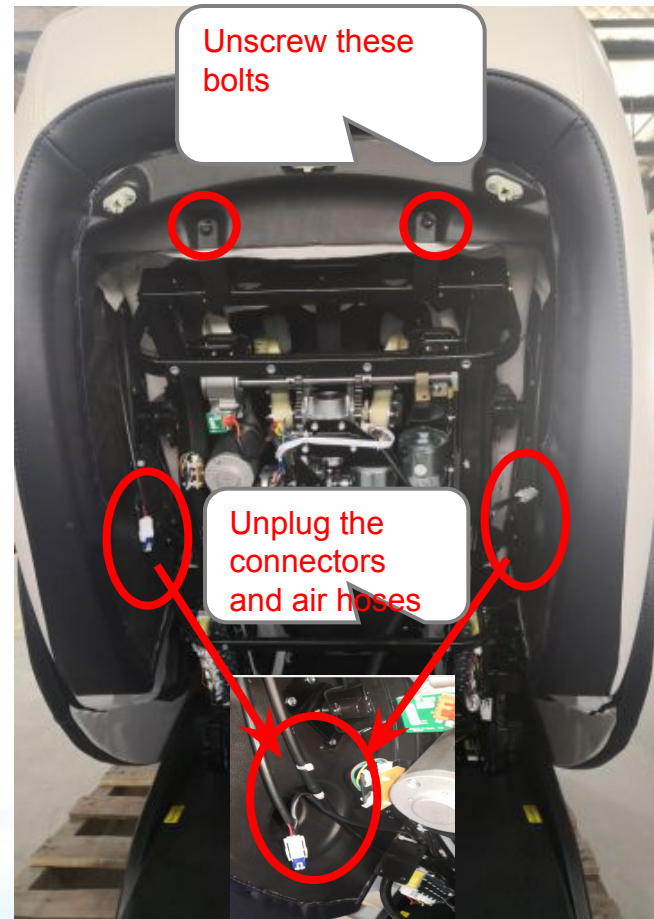

4.4 Mech Removal Guide



1 Unscrew 2 side bolts



2. Take off the Upper Limit Sensor Detection Board, but do not unplug it.

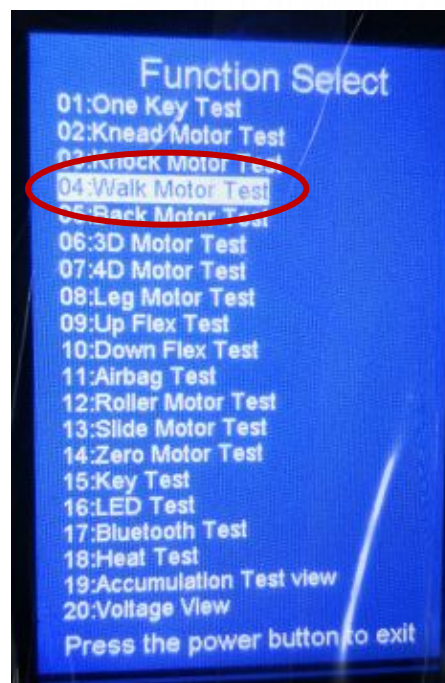

3. Enter background mode and choose walk motor test to run the mech until it stops at the top position.



4. Cut the cable tie, unscrew the bolt and unplug it, then take out whole Mech.

4.5 Mech motor removal guide

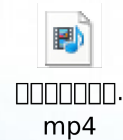
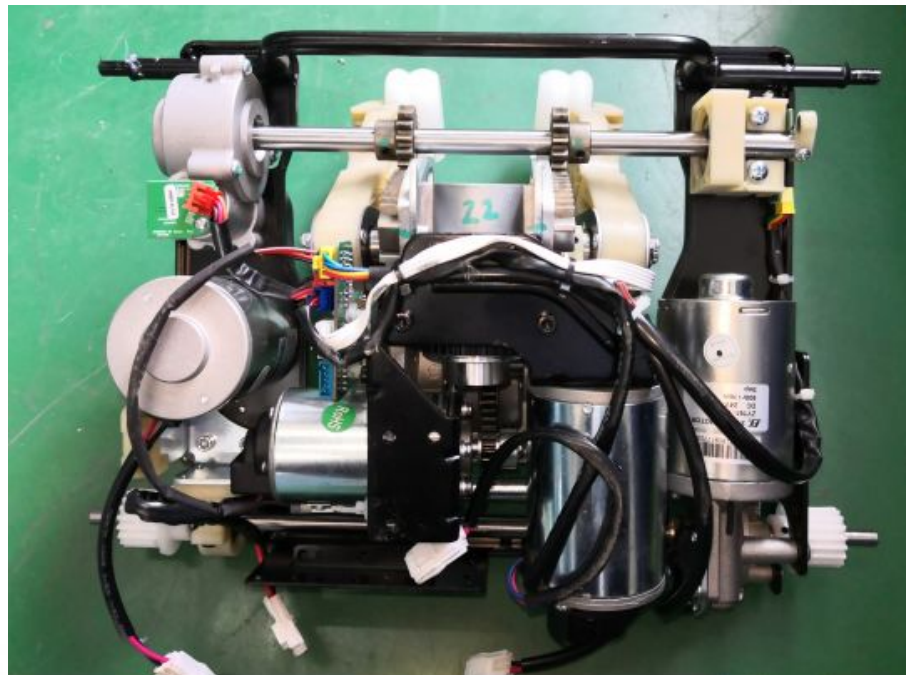

4.6 Power Box Removal Guide

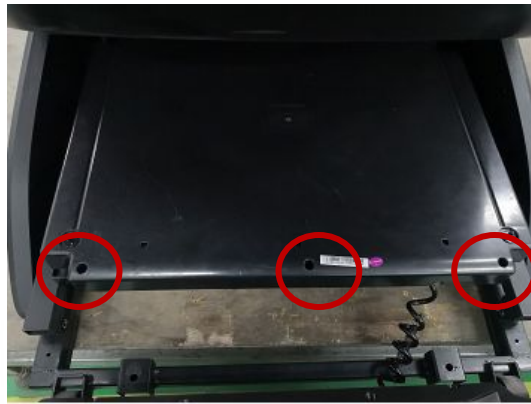

1. Unscrew the 3 bolts on the top cover and 3 bolts on the internal cover



2. You may replace: main board pcb, user connecting pcb, power board pcb, transformer, air pump and air valve.

4.7 Actuators Removal Guide

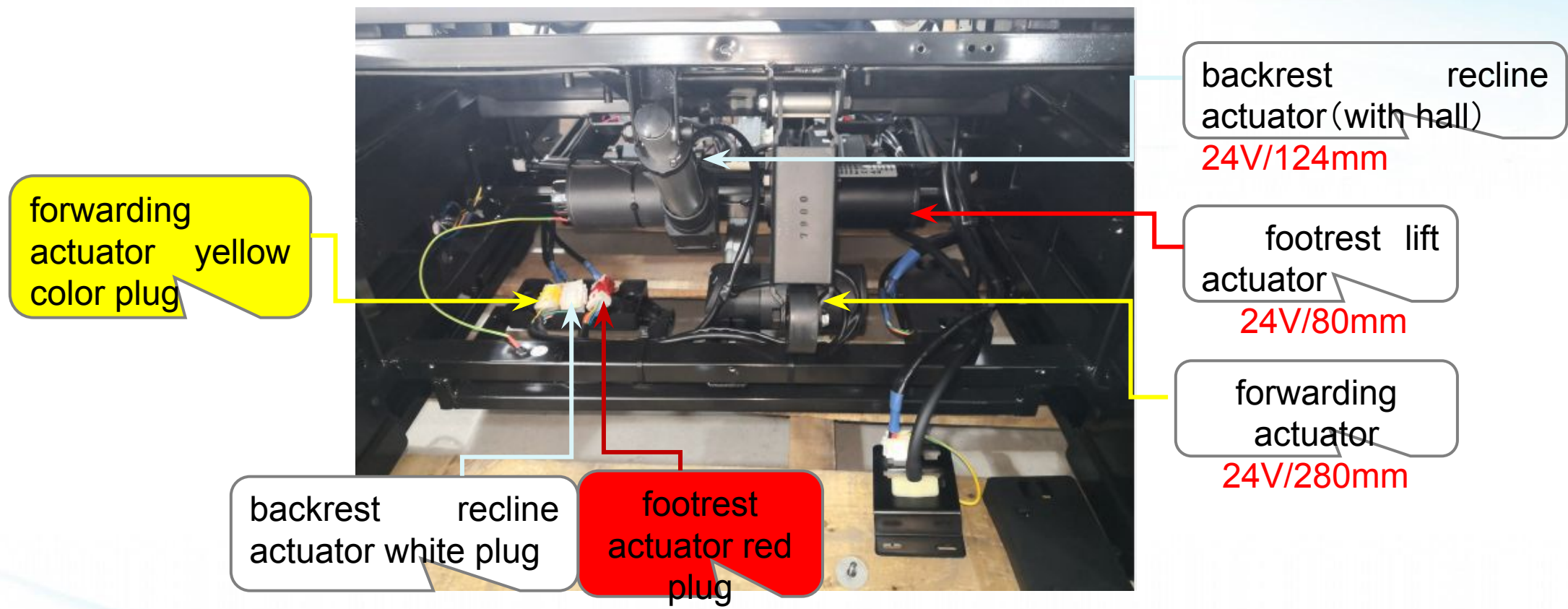

Remove the front and back cover board , unscrew the bolt at the front and back of actuator and unplug the connectors.

4.8 Footrest Extension Assembly Removal Guide



1. Unscrew these 4 bolts on the top cover board.

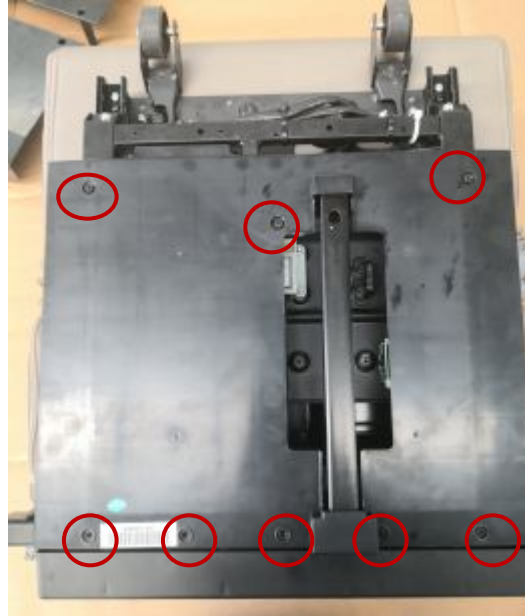

2. Unscrew these 7 bolts on the bottom cover board.



3. Unscrew the 6 bolts holding the extension unit, then remove the left 4 screws.

Troubleshooting

1.Remote controller does not start

2.Kneading motor does not work

3.Tapping motor does not work

4.Walking motor does not work

5. 3D vertical motor does not work

6.The fuse is blown

7.Footrest/backrest actuator does not work

8.Airbags fail to work

9.Foot extension does not work

10.Mech lost control

11.Charging does not work

1. Remote controller does not start

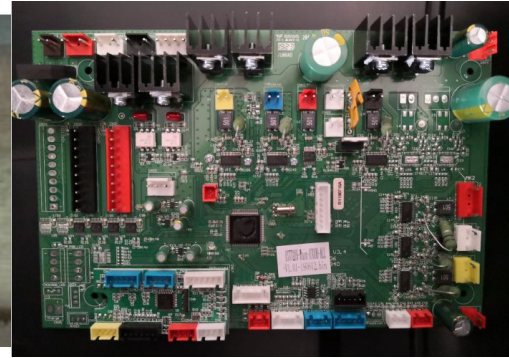

Analysis of causes:

- 1.Remote controller is damaged
- 2.5V power supply board is damaged
- 3.The main board is damaged
- 4.User connecting pcb is damaged
- 5.Remote plug-in unit cable is damaged

Method of exclusion:

- 1.Replace the remote controller.
- 2.Check the 5v power board indicator light to see whether it is on or off. If there is no light,then replace with a 5V power board.
- 3.Check the main board light to see whether it is on or off. If there is no light,then replaced with a main board.
- 4.If the light of main board is on, please replace with a user connecting pcb.
- 5.If no one above fix the problem, then replace a remote controller cable with plug connector.

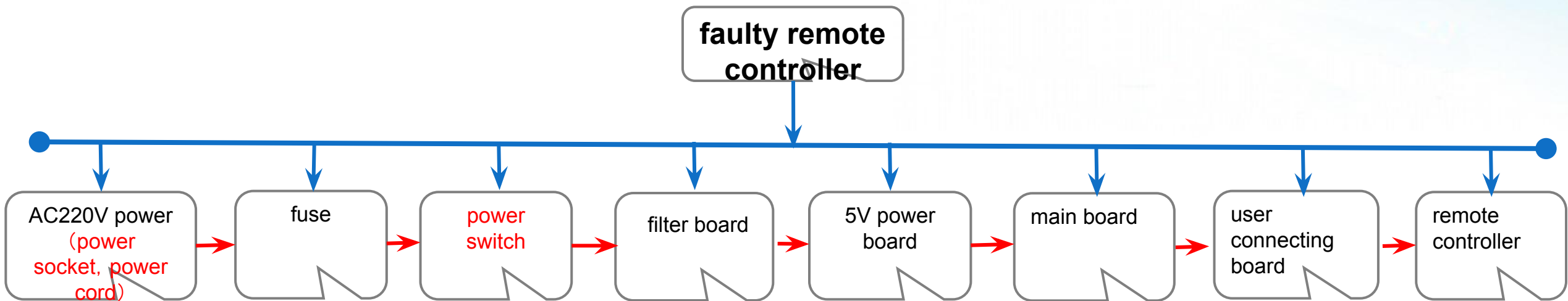

2. Kneading motor does not work

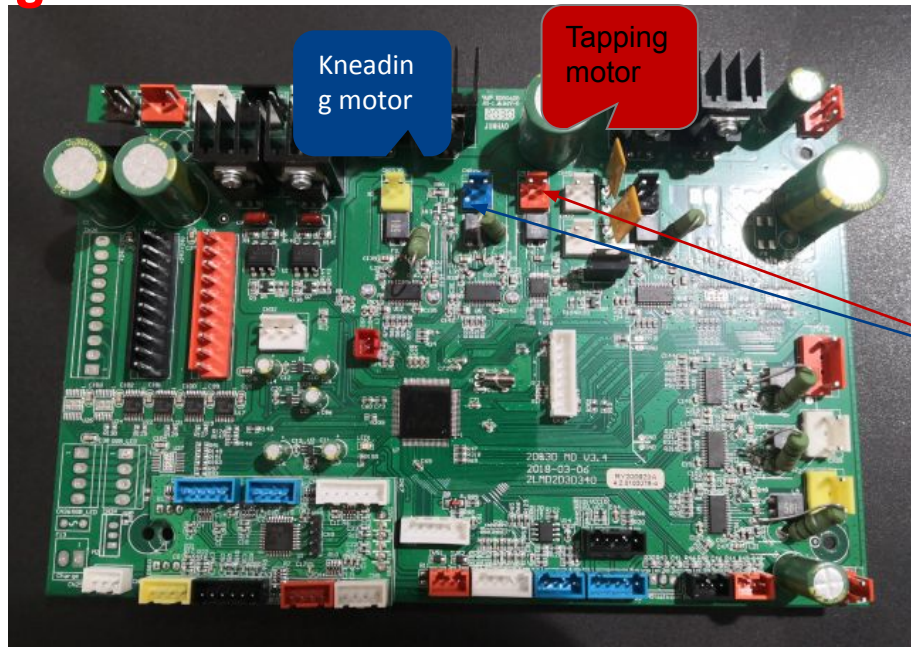

Picture 1

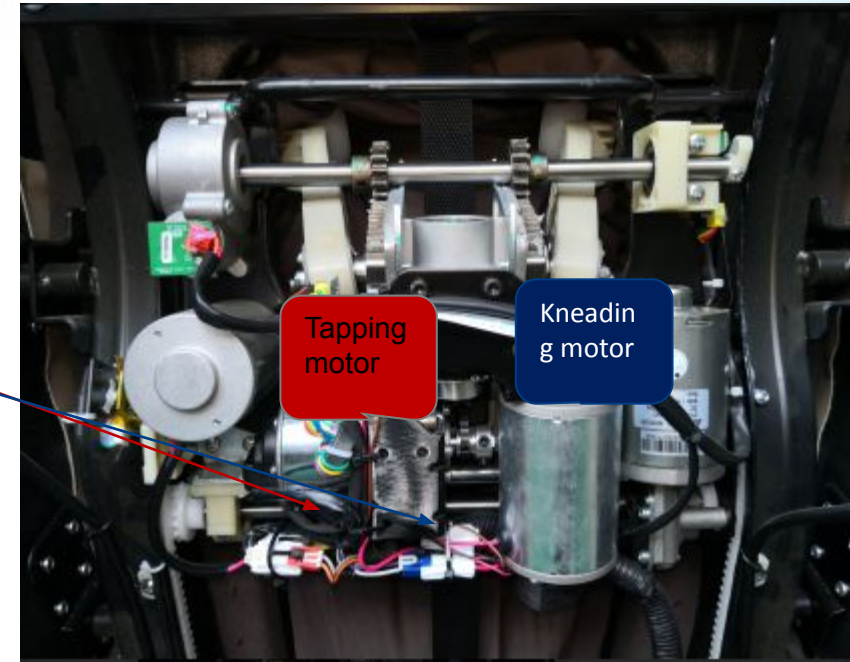

Picture 2

Analysis of causes:

- 1.Motor is damaged
- 2.Main board is damaged
- 3.Loose/broken connecting cable

Method of exclusion:

1.Use remote controller to power on chair, then select MANUAL mode---> SYNC message. Find the massage mech kneading motor plug (blue) and connect it to tapping motor plug (red). If the kneading motor does NOT work, then replace a new kneading motor, if it still works, then move to next step (might be main board or cable problem).

2.Plug the motor back to its original position, again power on chair and select SYNC message. Find the mainboard kneading motor plug (blue) and connect it with tapping motor plug (red). Check if the kneading motor works, if it works then replace a new mainboard, if no, replace a new connecting cable (can use a multi-meter to check the cable).

3. Tapping motor does not work

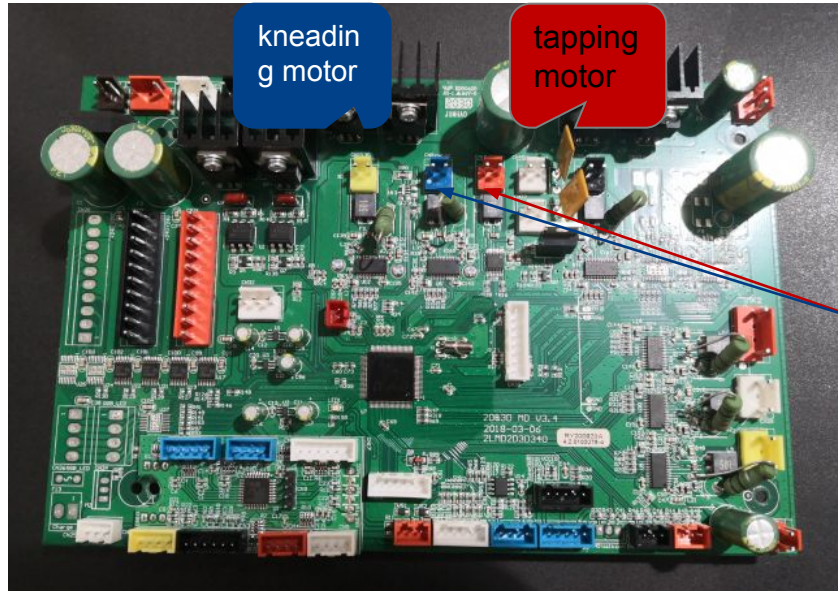

Picture 1

Analysis of causes:

1. Motor is damaged
2. Mainboard is damaged
3. Loose/broken connecting cable

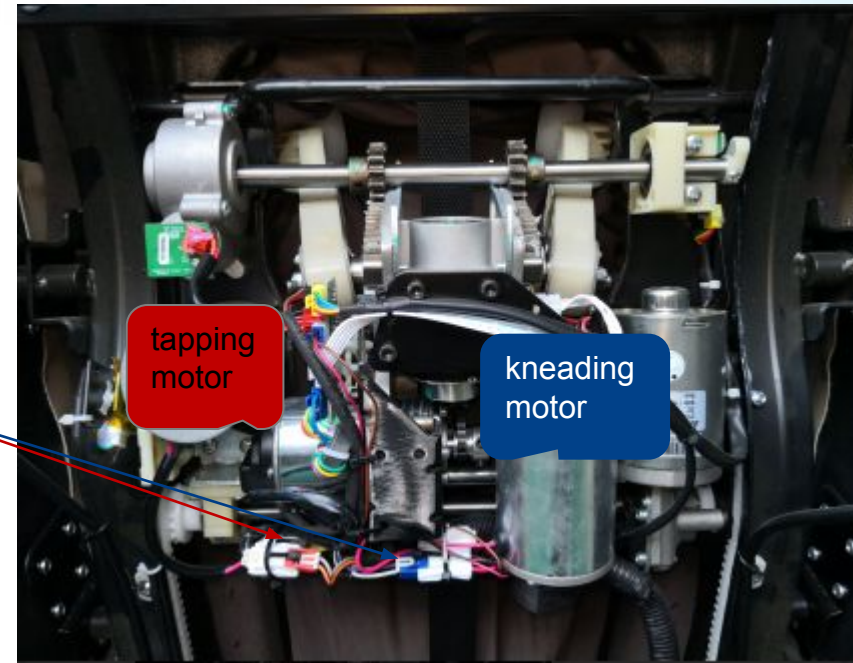

Picture 2

Method of exclusion:

1. Use remote controller to power on chair, then select MANUAL mode---> SYNC message. Find the message mech tapping motor plug (red) and connect it to kneading motor plug (blue). If the tapping motor does NOT work, then replace a new tapping motor, if it works, then move to next step (might be mainboard or cable problem).

2. Plug the motor back to its original position, again power on chair and select SYNC message. Find the mainboard tapping motor plug (red) and connect it with kneading motor plug (blue). Check if the tapping motor works, if it works then replace with a new mainboard, if no, replace with a new connecting cable (can use a multi-meter to check the cable).

4. Walking motor does not work

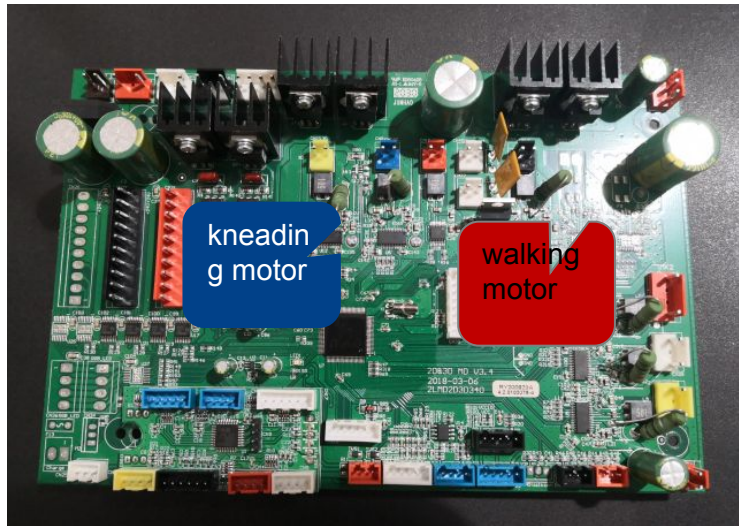

Picture 1

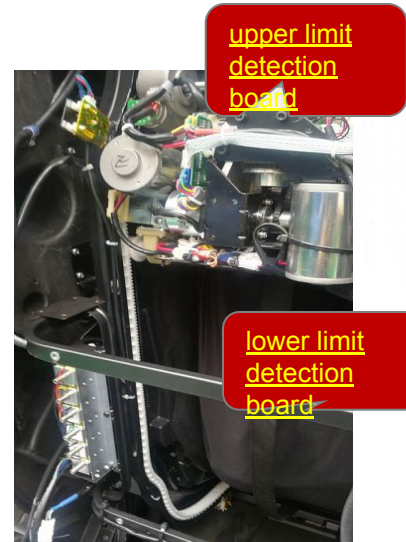

Picture 2

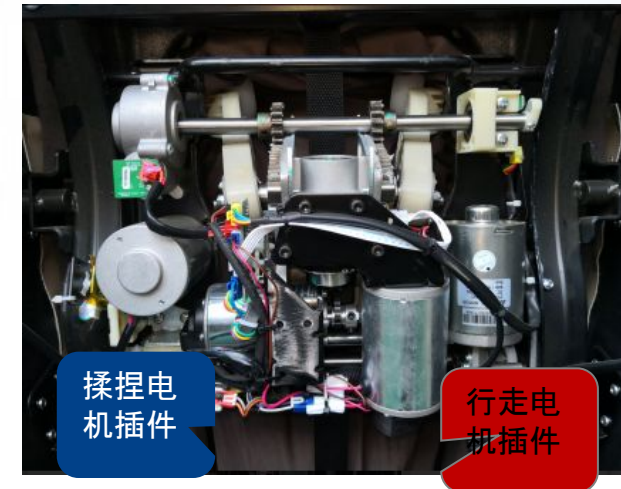

Picture 3

Analysis of causes:

- 1.The walking motor is damaged
- 2.Connecting cable is damaged
- 3.One of the limit sensor PCB is damaged
- 4.The main board is damaged

Method of exclusion:

- 1.Select MANUAL mode,SYNC message then POINT mode, press the “up” or “down” keys to check if there is double beeping sound from remote controller.
UP button: if NO double beeping sound, means that the UP limit detecting board is damaged or its cable is loose, check or replace with a new one;
Down button: if NO double beeping sound, means that the down limit detecting board is damaged or its cable is loose, check or replace with a new one;
- 2.If both have double beeping sound, means that limit detecting signal is good, then unplug mech motor plug (black) and connect it with kneading motor plug (blue) to check if motor works. If no, then replace with a new motor;
- 3.if motor moves, then plug the motor back to its original position. Find the walking motor plug on mainboard, exchange walking motor plug and kneading motor plug. If motor moves then replace main board, if no, means that motor cable is loose or broken, replace with a new cable.

5. 3D vertical motor does not work

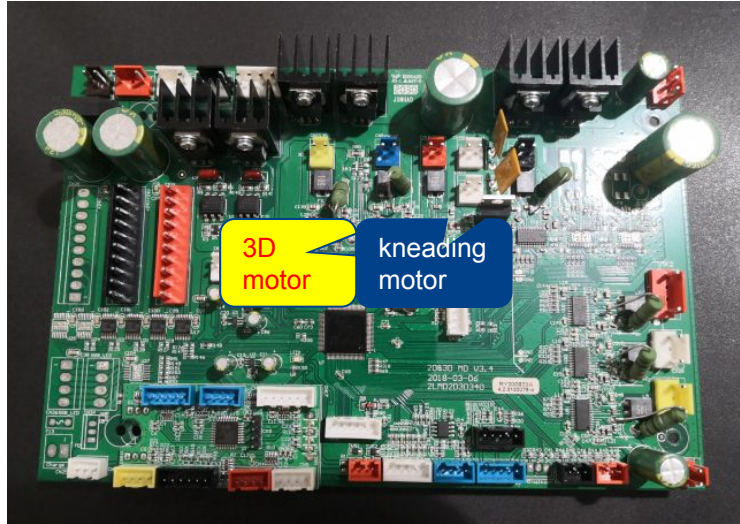

Picture 1

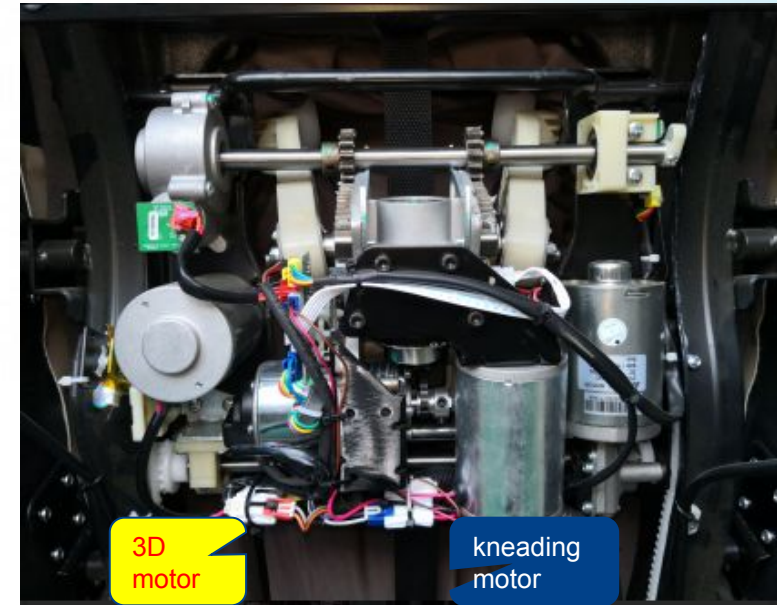

Picture 2

Analysis of causes:

- 1.Motor is damaged
- 2.Mainboard is damaged
- 3.Limit detecting board is damaged
- 4.Back connecting cable is damaged

Method of exclusion:

- 1.Select MANUAL mode, KNEADING massage. Find the massage mech 3D motor plug and switch it with kneading motor plug. If motor does not work ,replace with a new motor.
- 2.If it works, replug the motor to original position, open the power box, insert the yellow (vertical 3D motor) plug into the blue socket; If it does not work, replace the connecting cable or the poor connected pin (use multi-meter to test it).
3. If it works, then check the vertical 3D motor 5V voltage (red,yellow wire around 5V, yellow,blue wire around 4.5V, yellow green around 4.5V). If output voltage is normal, then replace limit detecting board. If no voltage, check the 3D interface board output voltage is normal or not, if its not normal, check the connecting cable pin or replace a new back connecting cable. If its normal, the mainboard is damaged, replace with a new mainboard.

(Attention: Please do not over run the 3D vertical motor during test.)

6. The fuse is blown



Picture 1

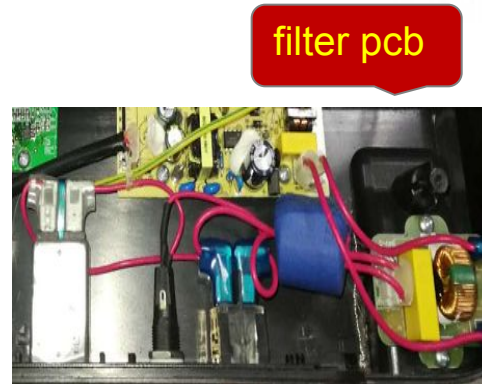

Picture 2

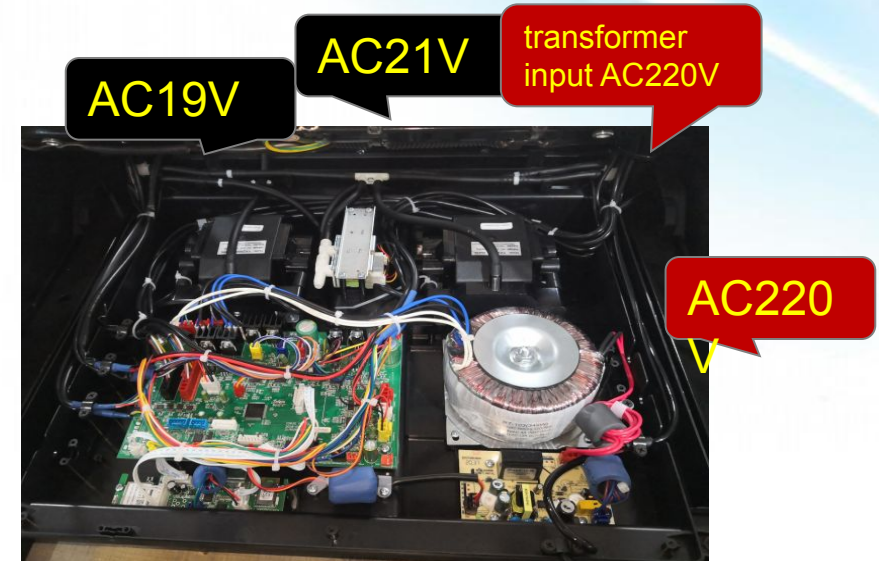

Picture 3

Analysis of causes:

1. Damaged fuse
2. Filtering pcb short circuited
3. Transformer short circuited
4. Mainboard damaged or short circuited
5. Connected parts short circuited, such as motor, air valve.
6. Power board short circuited

Tips: Transformer or filter pcb short circuited are the main reason for blown fuses.

Method of exclusion:

1. First, make sure the fuse is burned out. and replace the fuse with the same type if the voltage fluctuations cause the fire to burn out.
2. If the fuse continues to burn out, unplug the red plug and power on, if fuse burns again then replace a filter pcb.
3. If not, power off and re-plug the red plug, then unplug the AC19V&AC21V plug and power on, if fuse burns out, that means transformer short circuited, just replace with a new one.
4. If not, power off and re-plug AC19V&AC21V plug, then unplug the rest of plugs on the mainboard and power on; if fuse burns out, replace with a new mainboard;
5. If not, re-plug all plugs one by one to check which connected part short circuited. Replace with a new part upon confirmation of the short circuited parts.

7. Footrest/backrest actuator does not work

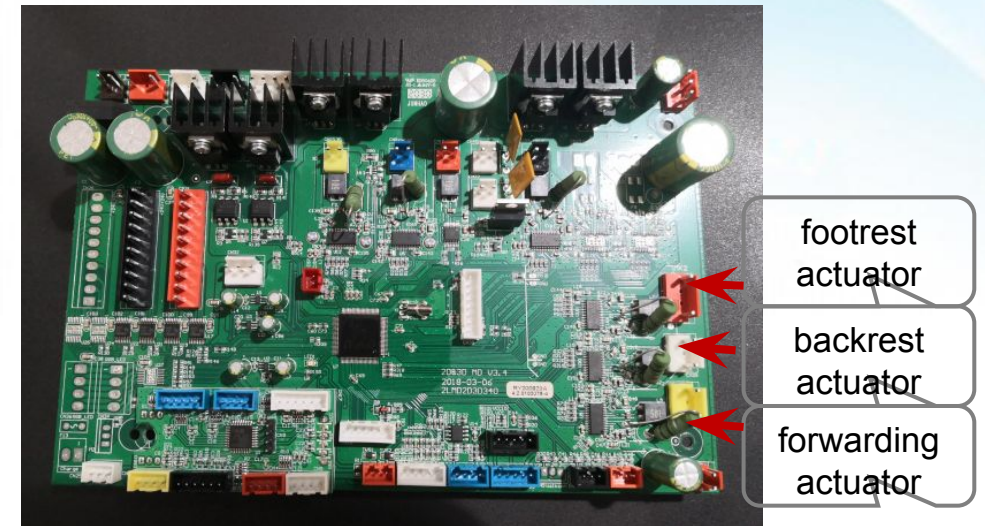
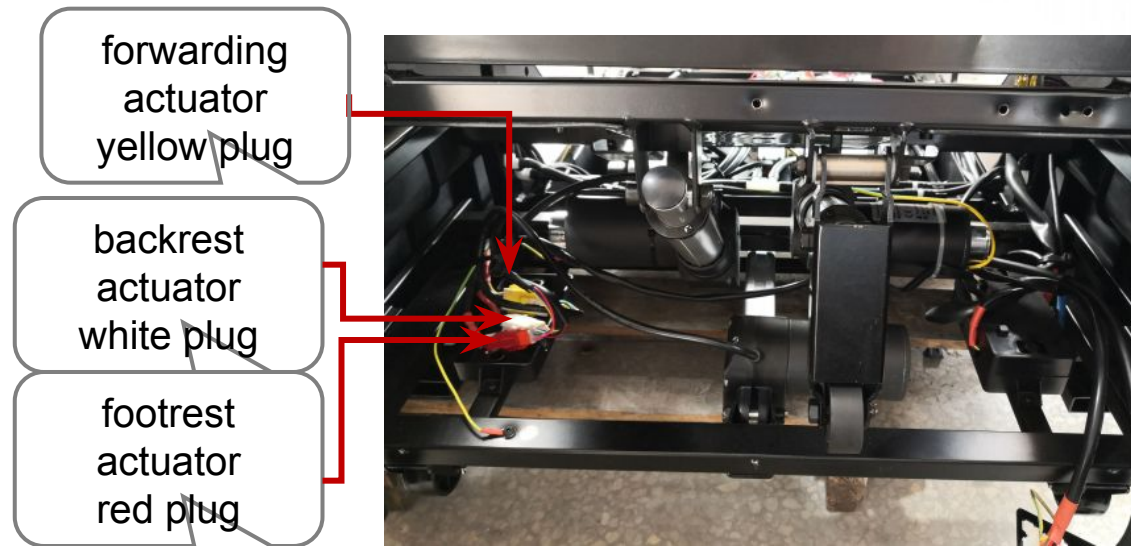

Analysis of causes:

- 1.The Actuator is damaged
- 2.The main board is damaged
3. Broken connection wire

Method of exclusion:

- 1.Exchange test method: plug the footrest lift actuator plug into the backrest actuator plug port,press the backrest raise/recline button,if the footrest can lift or lower,it indicates that the footrest lift actuator is good,then something went wrong with the mainboard or footrest lift actuator wire,use a multimeter to test the wire,if it is good,then the mainboard is faulty and need to be replaced.
2. If the footrest lift actuator fails to function after above exchange of plugs,the footrest actuator is faulty and need to be replaced.

8. Airbags fail to work



Picture 1

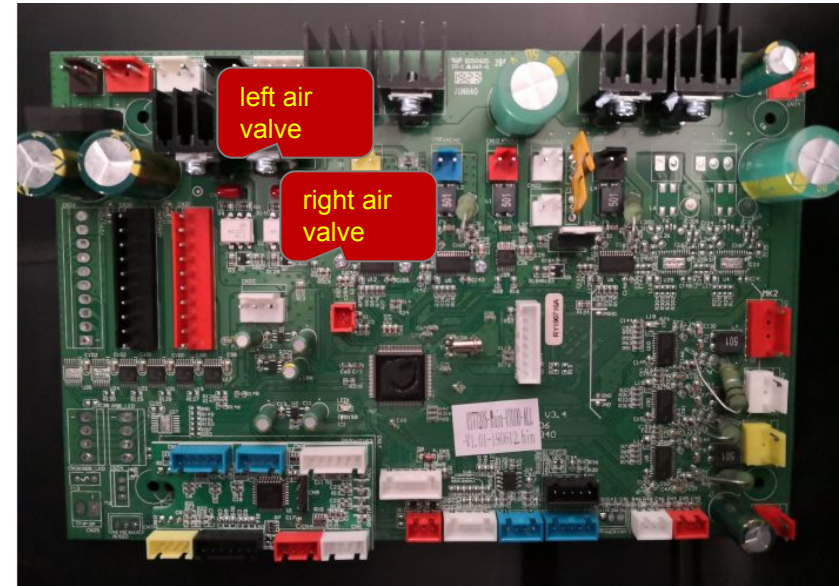

Picture 2

Analysis of causes:

1. Air hose folded or fell off
2. Air pump is damaged
3. Mainboard is damaged

Method of exclusion:

1. If part of the airbags fail to inflate, it indicates that the air compressor functions well, check the air hoses with mentioned issue to see if they are folded or fell off;
2. If air hose and airbags are good, use a multimeter Ω function to test air valve connector (Fig.1 Air valve for seat side airbag), if the black probe and red probe, the black probe and yellow probe read between 160-170, air valve is good, otherwise the air valve is damaged.

9. Foot extension does not work

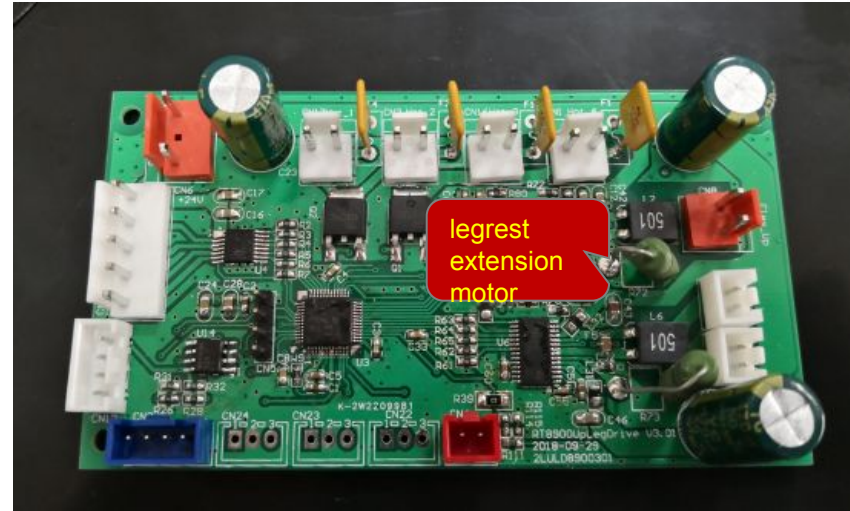
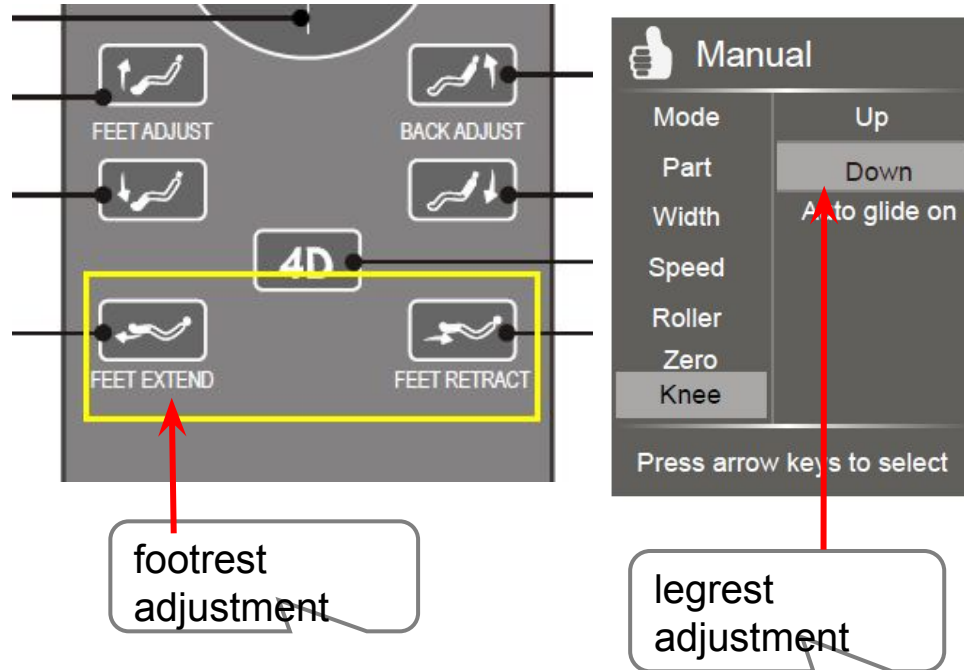

Picture 1

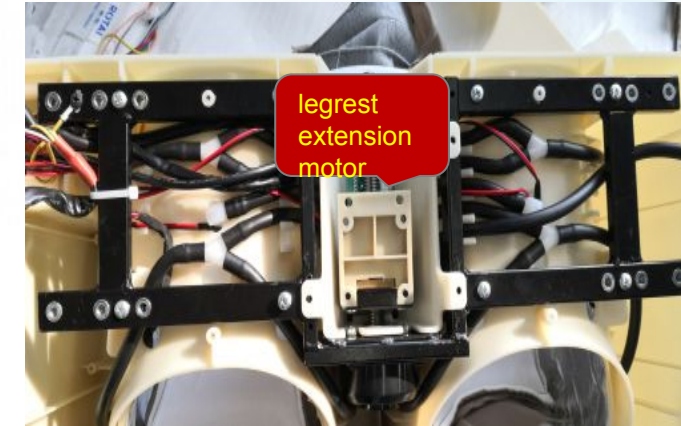

Picture 2

Possible reasons:

1. Main PCB
2. Leg extension motor
3. Harness from motor to main PCB

How to check:

1. Select legrest extension on remote, if there is no DC24V out from legrest PCB, then check DC24V output on main PCB: if DC24V comes out from main PCB, then legrest PCB is faulty; if no DC24V comes out from main PCB, then there is problem with power PCB.
2. There is DC24V out from main PCB, then check the resistance of extension motor: if resistance is huge or none, then motor or harness is faulty.

(If upper legrest stays at top or bottom and motor sounds working, the problem is on trip distance signal: like distance limit PCB or regarding harness is faulty, or the sensing magnet falls which need to do inner checking.)

10. Mech lost control

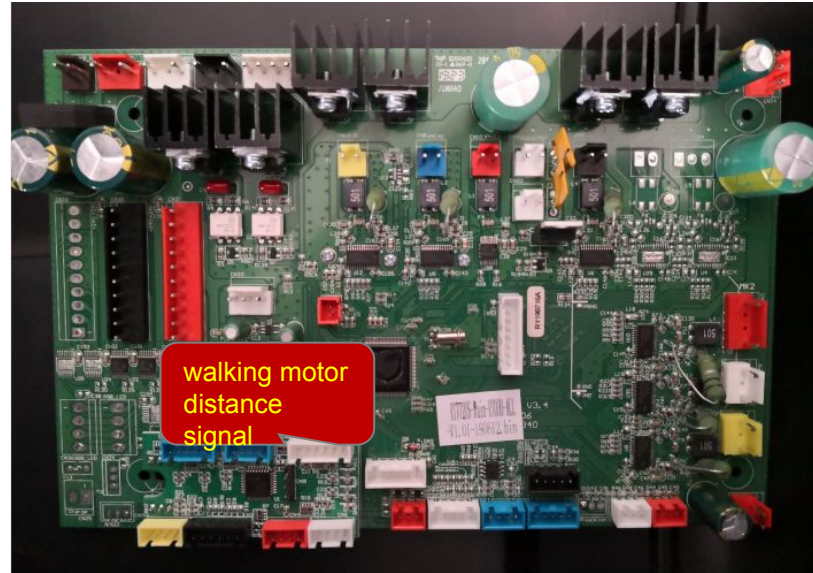

Picture 1

Analysis of causes:

- 1.Limit Sensor Detection Board damaged
- 2.Mainboard damaged
- 3.The wire harness which connects the mainboard and the limit sensor detection board is damaged or unsecured

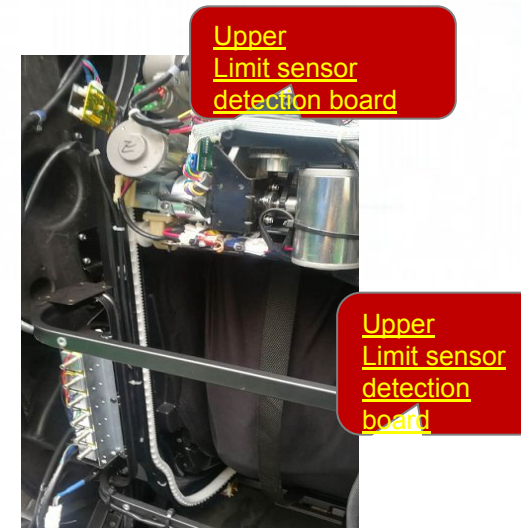

Picture 2

Method of exclusion:

- 1.Check if the plug is loose,the pin of the plug fell off,or the connection wire is damaged. If the mechanism overruns all the way up,replace the upper limit sensor detection board;otherwise replace the lower limit sensor detection board(check picture 2 for reference).
- 2.If problem remains after above limit sensor detection board replaced,replace the mainboard.

12.Charging does not work

DC24V
charging

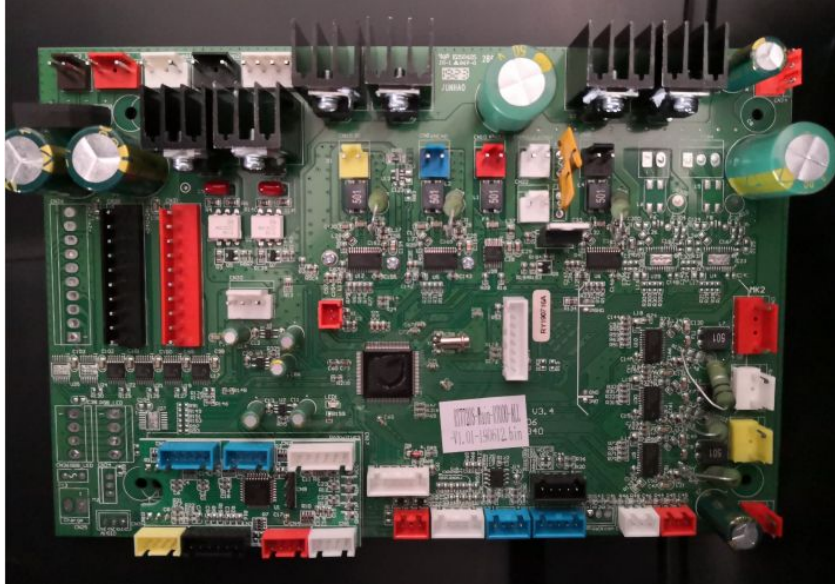

Picture 1

- 1.Charging board is damaged
- 2.Mainboard damaged
- 3.The wire harness which connects the mainboard and the charging board is damaged or unsecured
- 4.Charging holder is damaged



Picture 2

- 1.Check if the plug is loose,the pin of the plug fell off,or the connection wire is damaged.
- 2.Use a multimeter to test the DC24V voltage input of charging board,if there is no such input voltage,the mainboard orthe wires connecting the mainboard and the charging board is damaged,can be tested by a multimeter to confirm. (picture 2 grey color)
- 3.If the DC24V voltage is normal,use the multimeter to test DC9V output,picture 1 red color, if there is no such output voltage,the charging board is damaged and need to replaced.

ROTAI
荣泰

ROTAI
荣泰

**Thank
you !**

上海荣泰健康科技股份有限公司
SHANGHAI RONGTAI HEALTH TECHNOLOGY CORPORATION LIMITED