

## After-sales service of A100 Massage chair



Intelligent  
Massage ! !



Intelligent Massage !!



**Transformer**

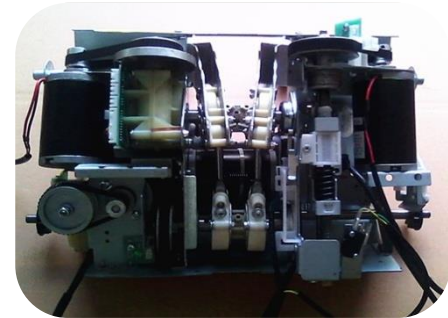

**Massage hand**



**Touch screen**

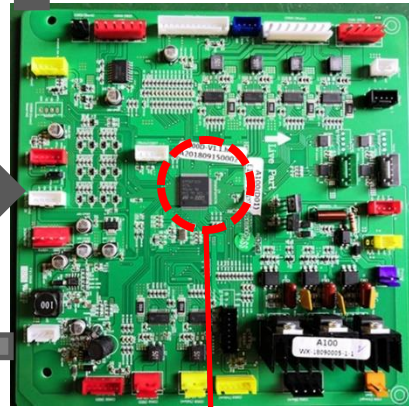

**CPU chip**



**Valve**

Signal transmitting

**Lifting motor**



**Air Pump**

# Inner structure & disassembly of Product

- 1、 Appearance part name**
- 2、 Inner structure diagram**
- 3、 PCB plug-in diagram**
- 4、 Product disassembly diagram & video**



## 1、 Appearance part name

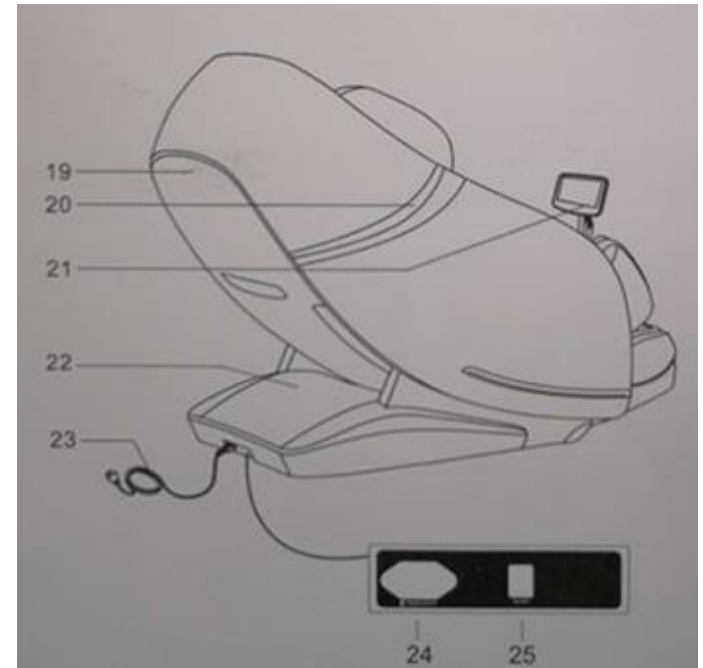
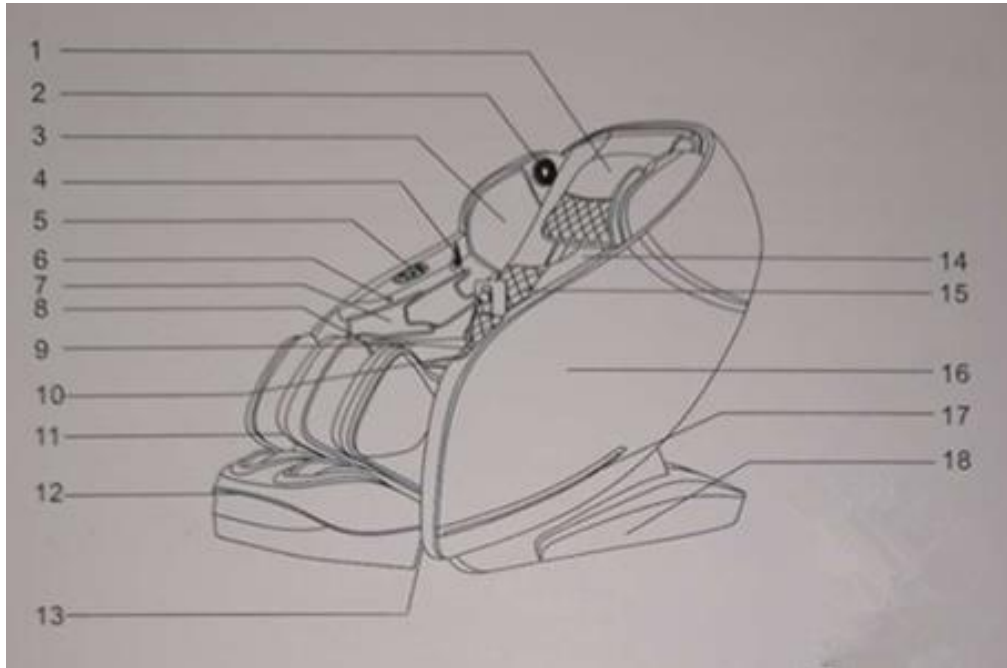

- |                               |                                   |                                    |
|-------------------------------|-----------------------------------|------------------------------------|
| 1. Pillow Pad                 | 10. Touch screen controller stand | 19. Back Cover                     |
| 2. 3D digital Speakers        | 11. Calf Massage Assembly         | 20. Armrest Decoration             |
| 3. Upper Arm Air Bag Assembly | 12. Foot Massage Assembly         | 21. Touch screen remote controller |
| 4. O <sub>2</sub> Ionizer     | 13. End Sealing Plate             | 22. PCB Box Cover                  |
| 5. Shortcut Button            | 14. Back Cushion                  | 23. Power Cord and plug            |
| 6. USB Charging Port          | 15. Back air massage              | 24. Power Cord Socket              |
| 7. Arm Air Bag Assembly       | 16. Armrest                       | 25. Power Switch                   |
| 8. Phone pocket               | 17. LED Lights                    |                                    |
| 9. Seat Cushion               | 18. Side panel                    |                                    |

## 2、 Inner structure diagram

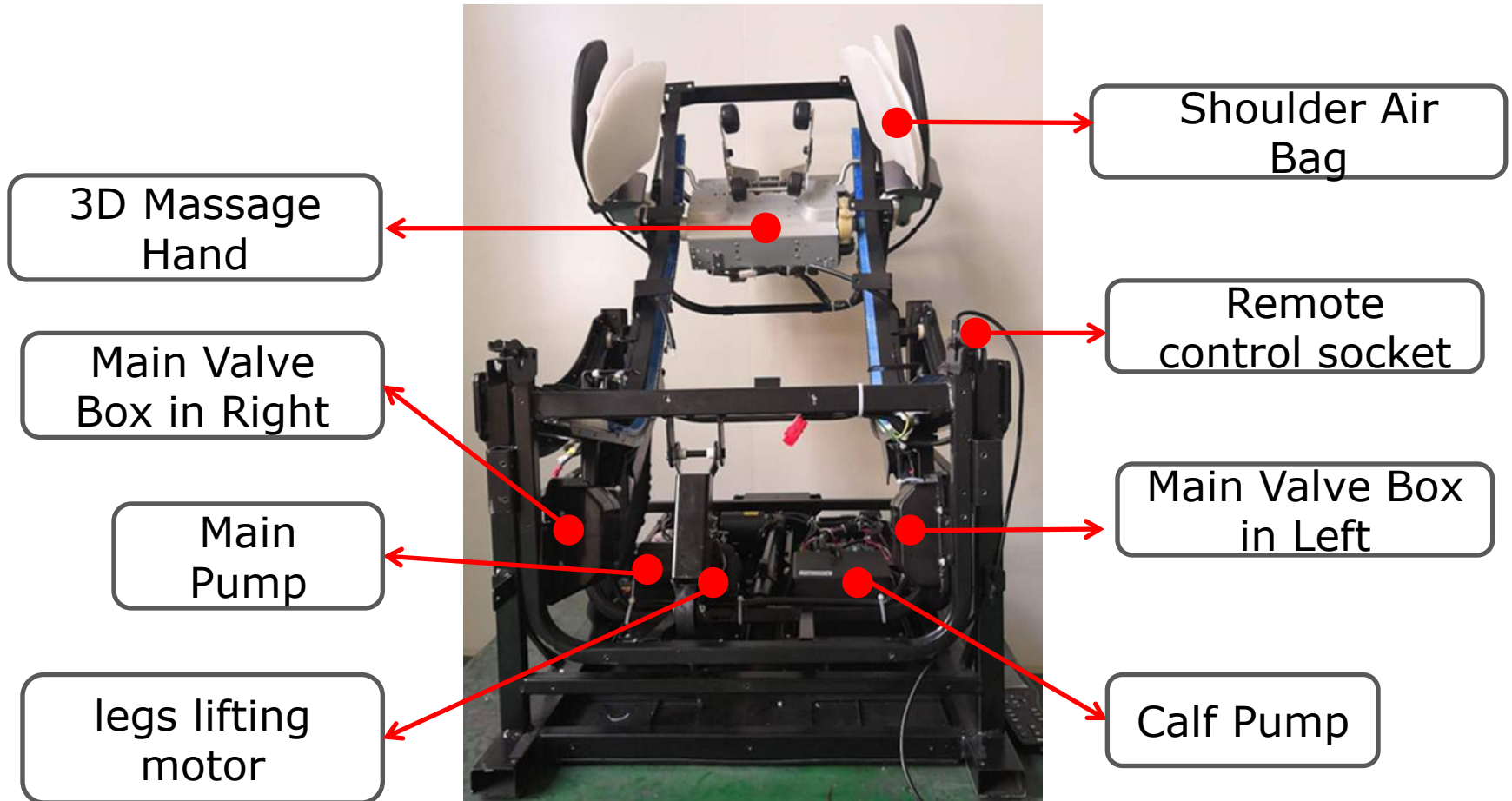

## 2.1、 Inner structure diagram

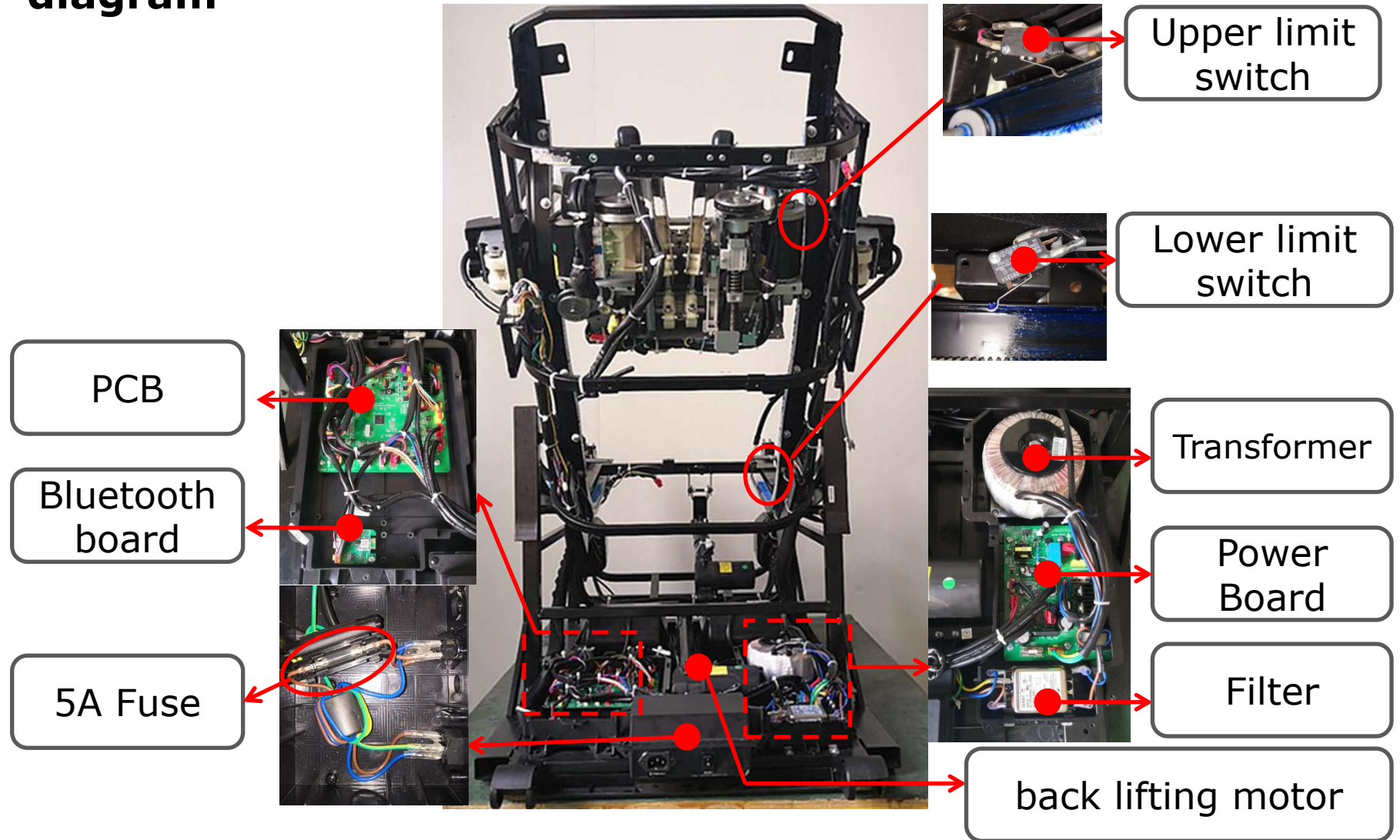

## 2.2 Massage hand structure diagram

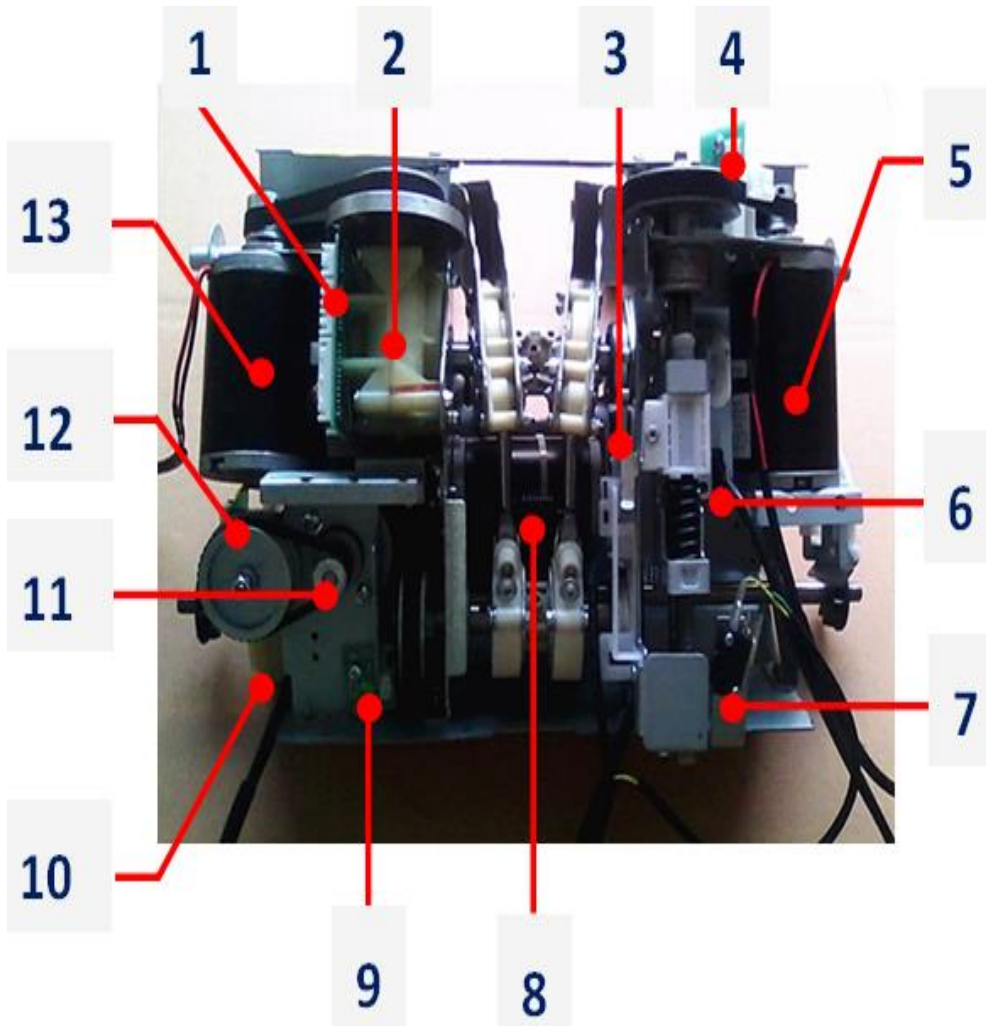

1. Travel detection & signal board
2. Kneading gearbox assembly
3. stretch upper limit switch
4. stretch walking laps testing board
5. stretch motor
6. Neck & shoulder pressure detection potentiometer
7. stretch lower limit switch
8. Tapping motor
9. Tapping motor swing hip synchronization detection board
10. Traveling motor gearbox
11. Traveling motor
12. Traveling laps testing board
13. Kneading motor

## 3、PCB plug-in diagram

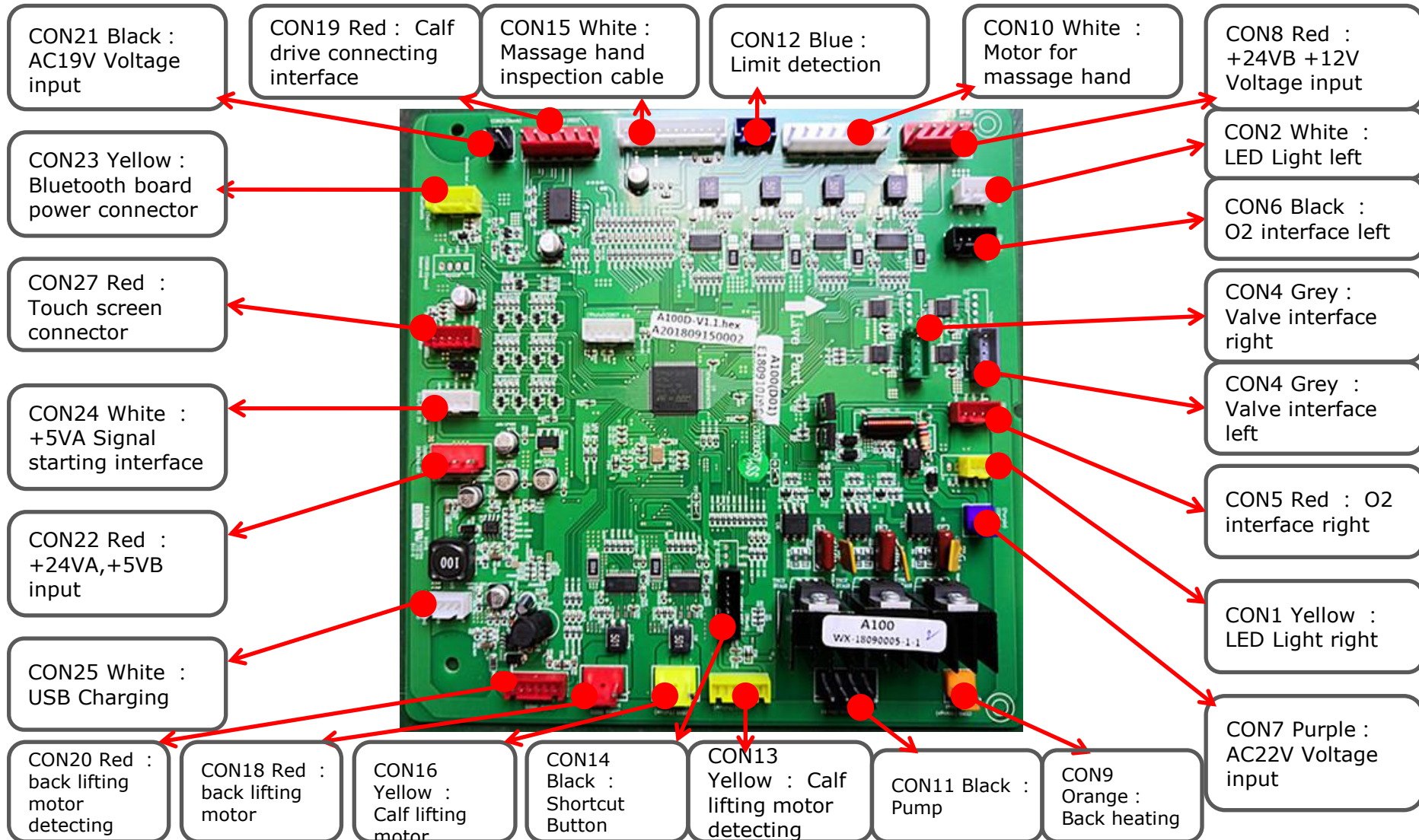

## 3.1、 Power Board plug-in diagram

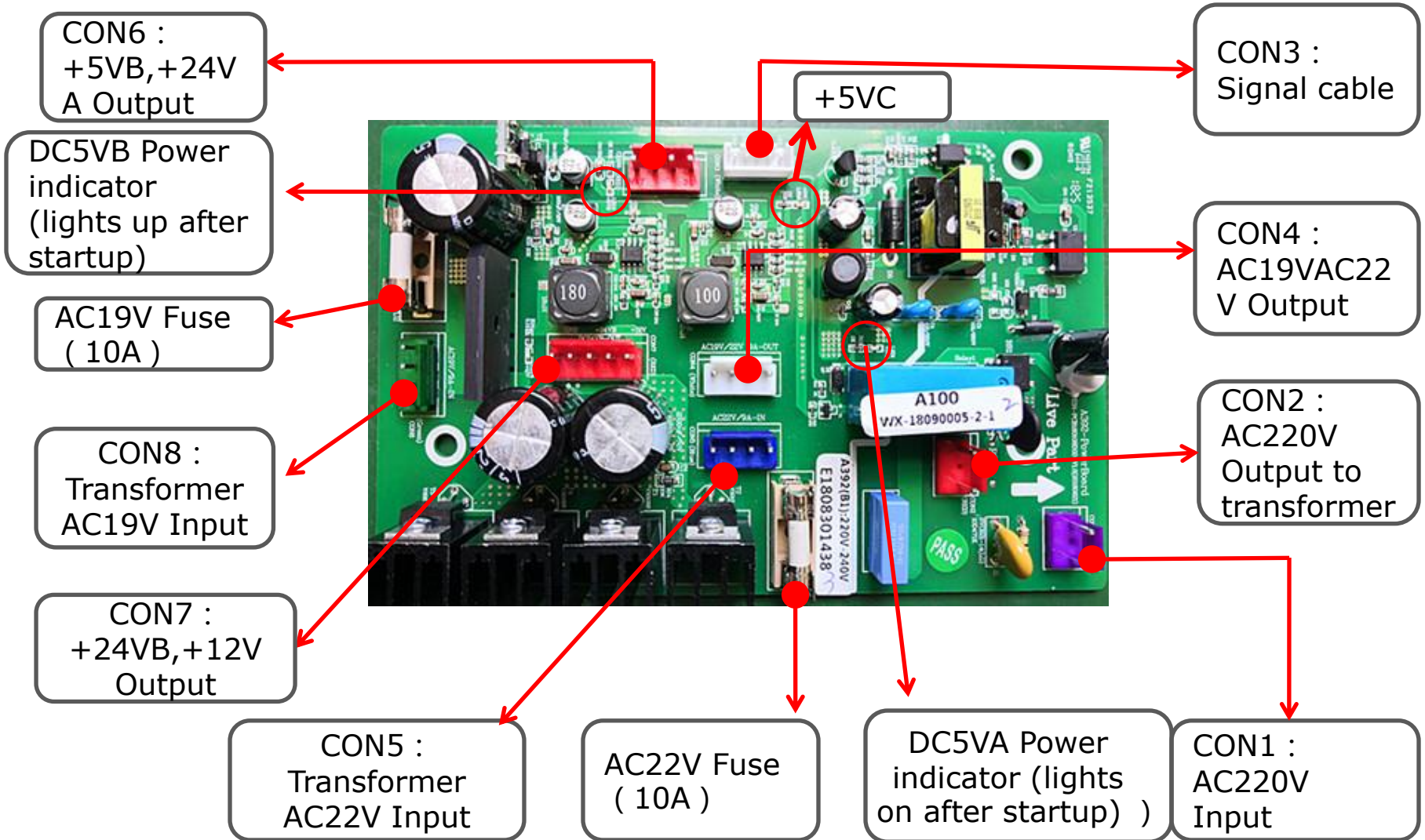

## 4、 Calf installation diagram & video



**A、 Remove the cover on both sides of calf**



**B、 Lift the cover on both sides**



**C、 Secure harness and air pipe**



**D、 Sleeve the cover on both sides of calf and hang it on mainframe**

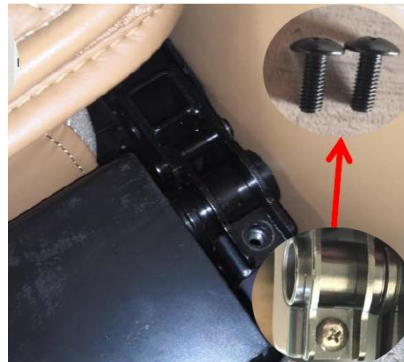

**E、 Fastening gland screws**



**F、 Fasten protective cover and place leather**

**( Calf installation video )**



## 4.1、 Armrest installation diagram & video



A、 Connect air pipe and harness, set protective cover



B、 Install the front and rear ends of armrest and fix two screws at front.

( **Mainframe video** )



## 4.1、 Armrest installation diagram & video

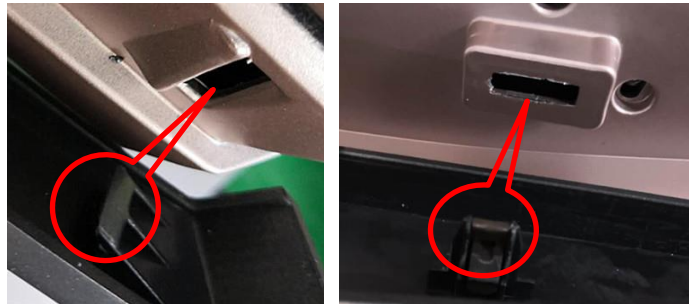
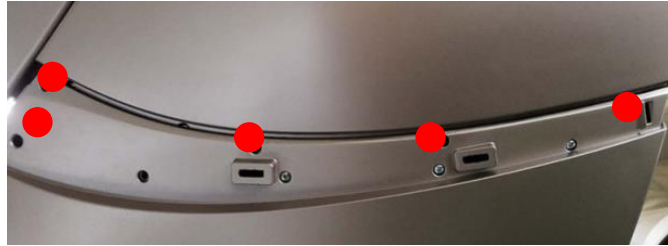

A、 Fix the 5 screws on the back of armrest and fasten decorative strip

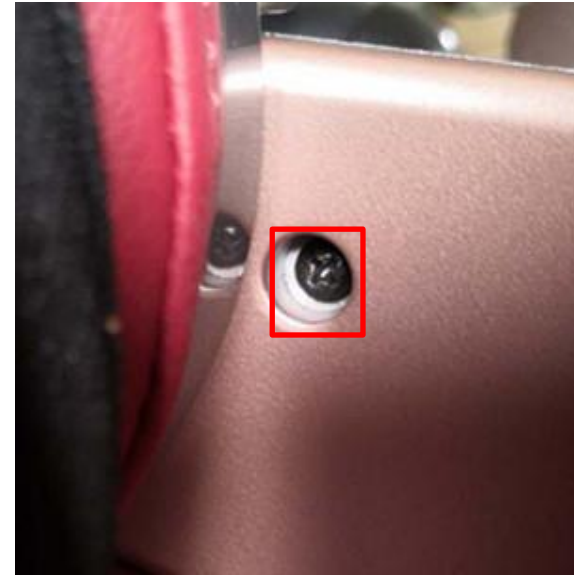

B、 Fix the screws of armrest decorative strips, finished. Same to the other side.

( **Armrest installation video** )



## 4.2、 Rack rear cover drive cover installation diagram & video

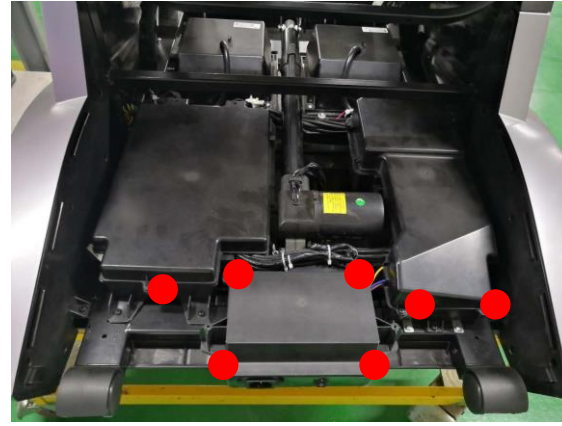

A、 Remove the 2 screws from back cover of frame

B、 Remove the red dot marking screws on cover of PCB box

( **Frame back cover installation video** )



## 4.3、 Seat side cover installation diagram & video

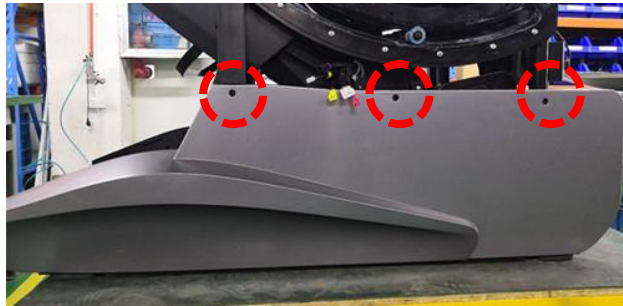

A、 Remove three screws from side cover of the seat

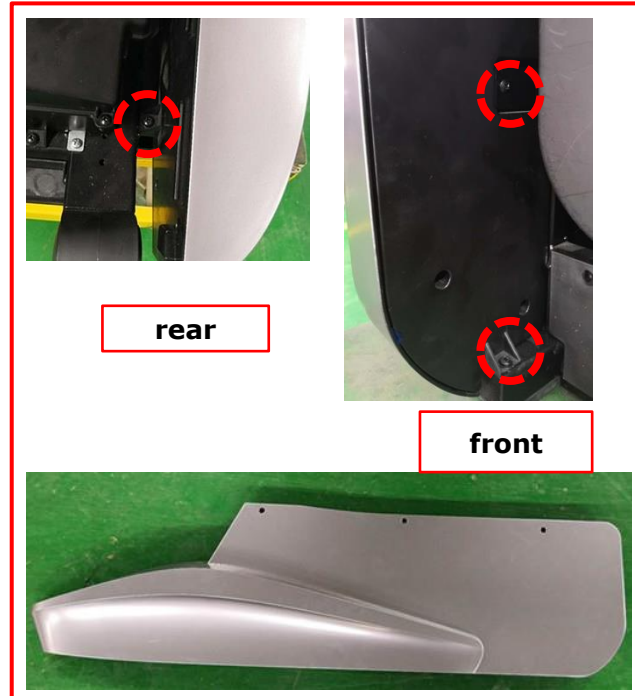

B、 Remove the front and rear end fixing screws of side cover and remove side cover

( **Seat side cover installation video** )



## 4.4、 Massage hand and motor installation diagram & video

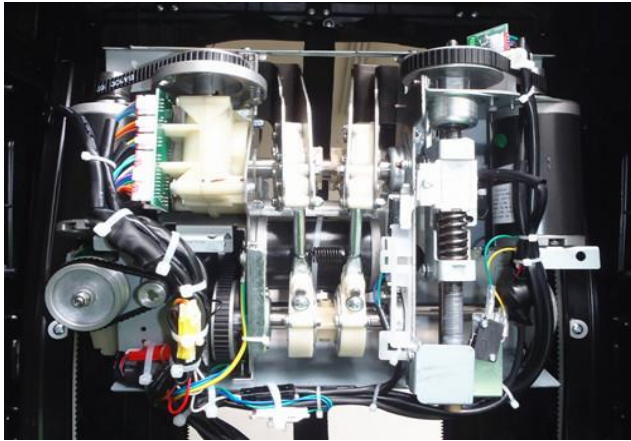

( [Kneading motor installation video](#) )



( [stretch motor installation video](#) )



( [3D Massage hand installation video](#) )



A、 Cut harness tie of massage hand  
**Pls. pay attention to the wiring harness wiring method for installation**

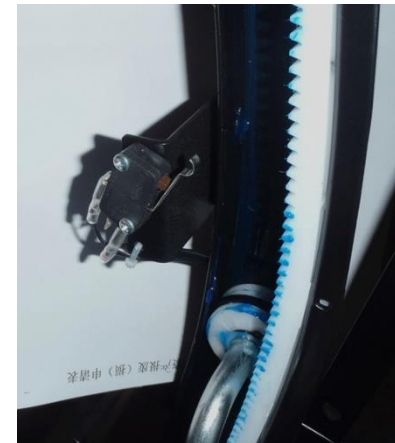

B、 Remove upper end limit screws on both sides of back steel frame rail, and then remove upper limit switch. Finally, rotate travel motor belt to remove whole massage hand.

## 4.5、 Space capsule and back cover installation diagram & video



**1**



**2**

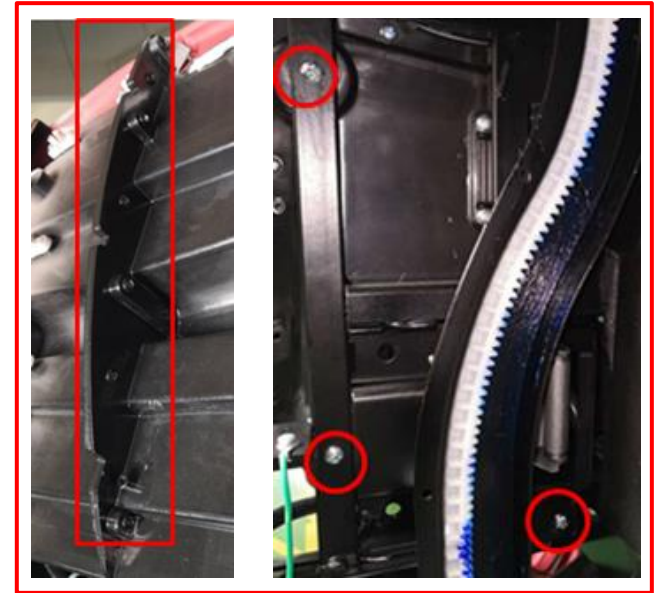

**3**

- Step 1: Remove 4 screws on the back cover and remove back cover
- Step 2: Remove 4 screws in the red ring on the inside of capsule cover and then remove cover.
- Step 3: Remove left and right space capsule connecting screws and inner side fixing screws
- Step 4: Separate harness to remove left and right capsule components

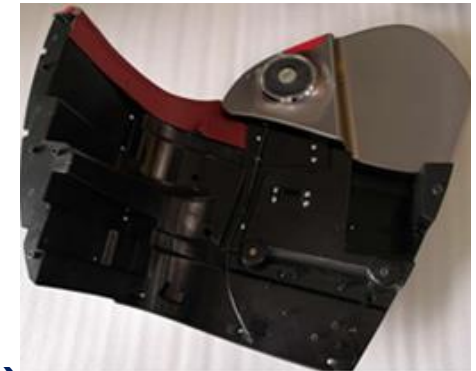

**4**

**( [space capsule installation video](#) )**

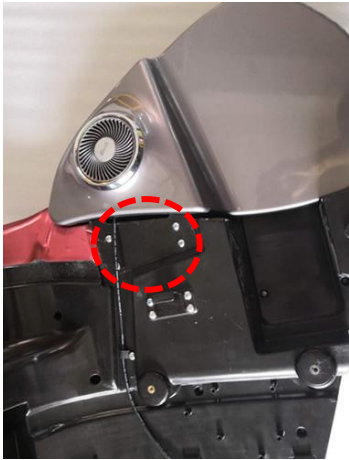

## 4.6、 Speaker and its' decorative cover installation diagram & video

**1**

A、 Remove 6 screws that fix speaker assembly and space capsule first.

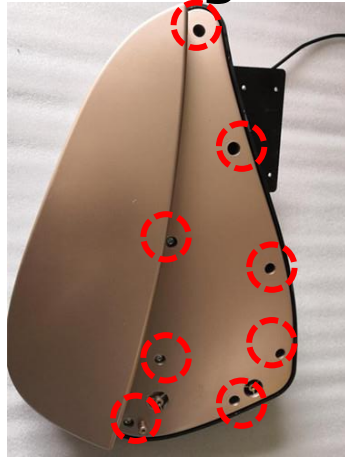
**2**

B、 Then remove speaker cover fixing screw and separate cover

**3**

C、 Finally, speaker fixing screw and the cover can be removed and replaced.

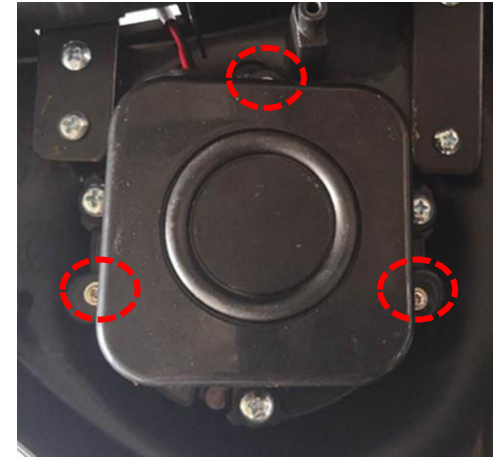
**4**

( [Speaker and its' cover installation video](#) )



## 4.7、Upper arm air bag installation diagram & video

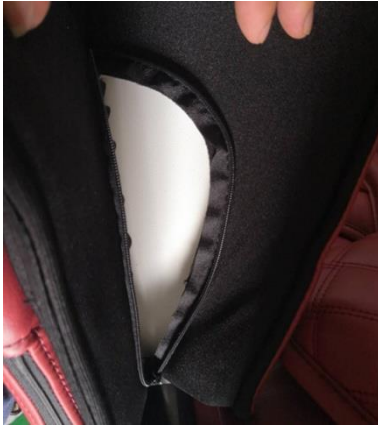

A、 Open upper arm airbag cover front zipper to remove two screws that fix air bag first.



( Upper arm air bag installation video )



B、 Then pull zippers on both sides and remove 4 screws that fix baffle. You can see that air bag can be replaced by removing air pipe.



## 4.8、Armrest trim panel installation diagram & video



Car buckle to fixed airbag

1

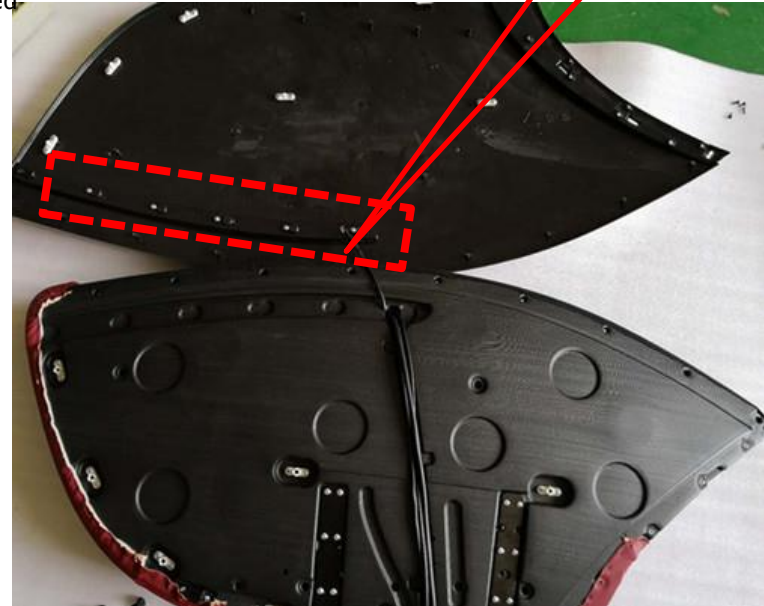

Armrest light bar fixing screw

2

A、 Remove car buckle that fixes arm airbag, and remove three screws inside first. **Fig1**

B、 Then remove the remaining screws that secure cover. **Red marking in Fig1**

C、 Finally, remove cover and remove light strip lightly.

( Armrest trim panel installation diagram & video )

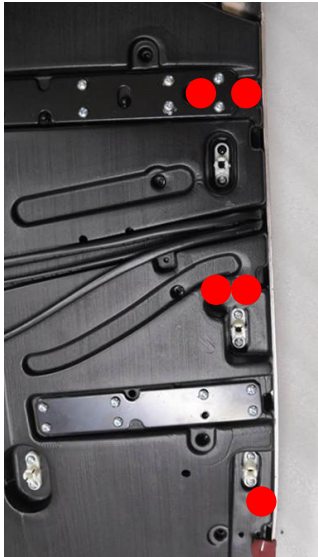
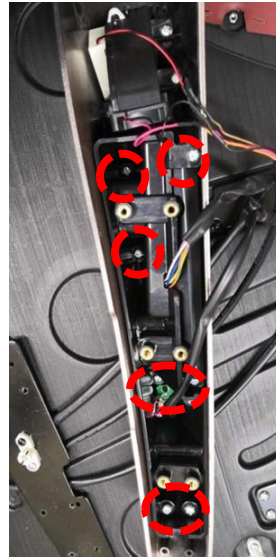
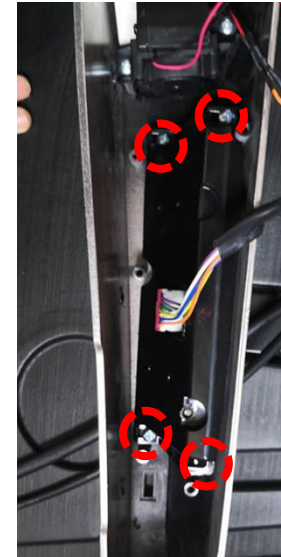

## 4.9、Short cut button installation diagram & video

**1****2****3****4****5**

- A、 First of all, this step is completed on basis of armrest cover removal.
- B、 Remove the marking screws according to numerical order in figure
- C、 Finally, remove button board and fix screw to remove button board.

**( Short cut button installation diagram & video )**



## 4.10、 Calf massage assembly structure and disassembly

### 4.10.1 External structure

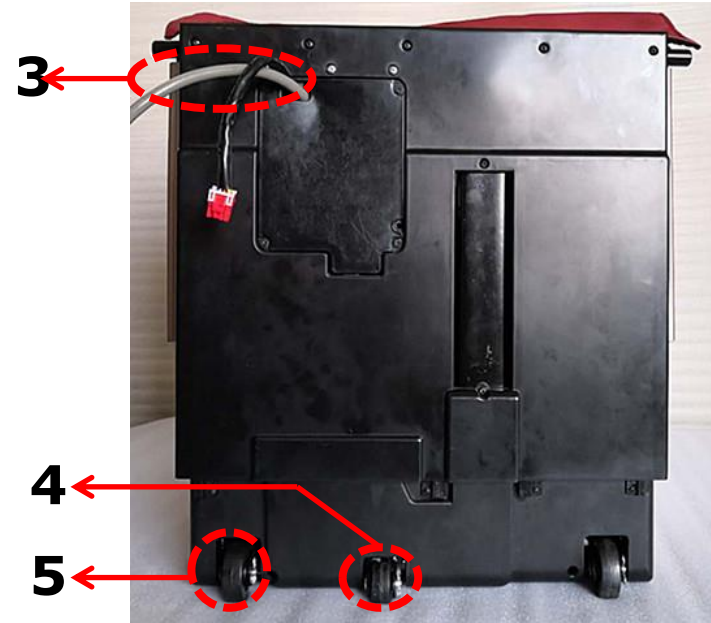
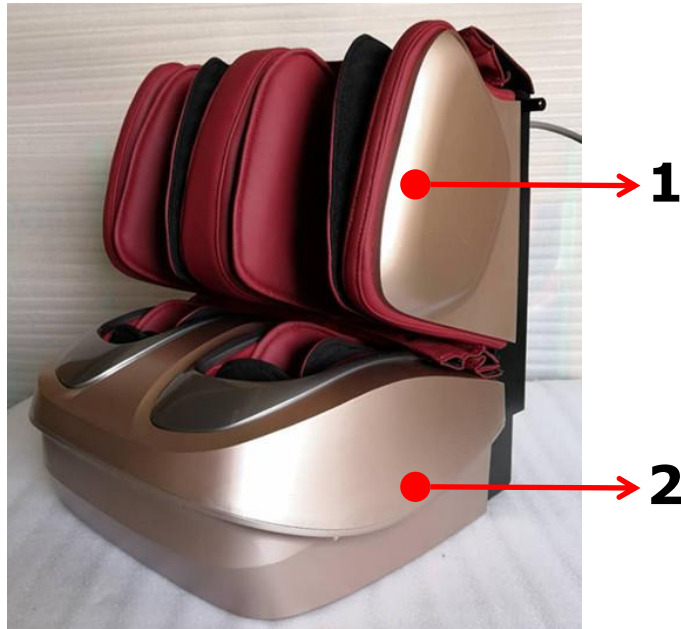

1. Leg rest 2. Foot 3.Pipe, wire 4. Ground switch 5. Rear caster

## 4.10、 Calf massage assembly structure and disassembly

### 4.10.2 Inner structure

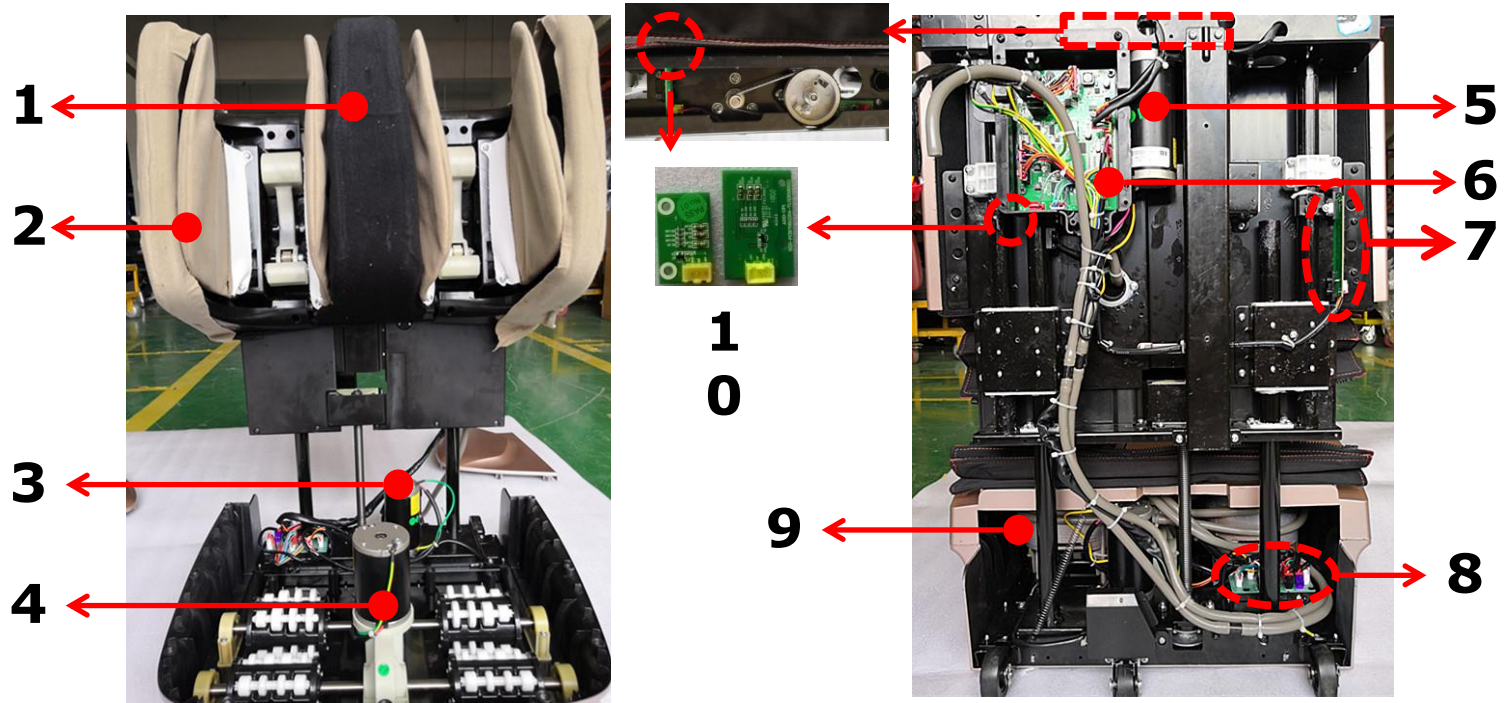

1. Kneading component
2. Leg airbag
3. Footrest stretch motor
4. Foot roller motor
5. Leg rest stretch motor
6. Calf PCB
7. Leg limit detection board
8. Adapter plate
9. Foot air bag assembly
10. Foot limit detection board

## 4.10、 Calf massage assembly structure and disassembly

### 4.10.3 Calf PCB plug-in diagram

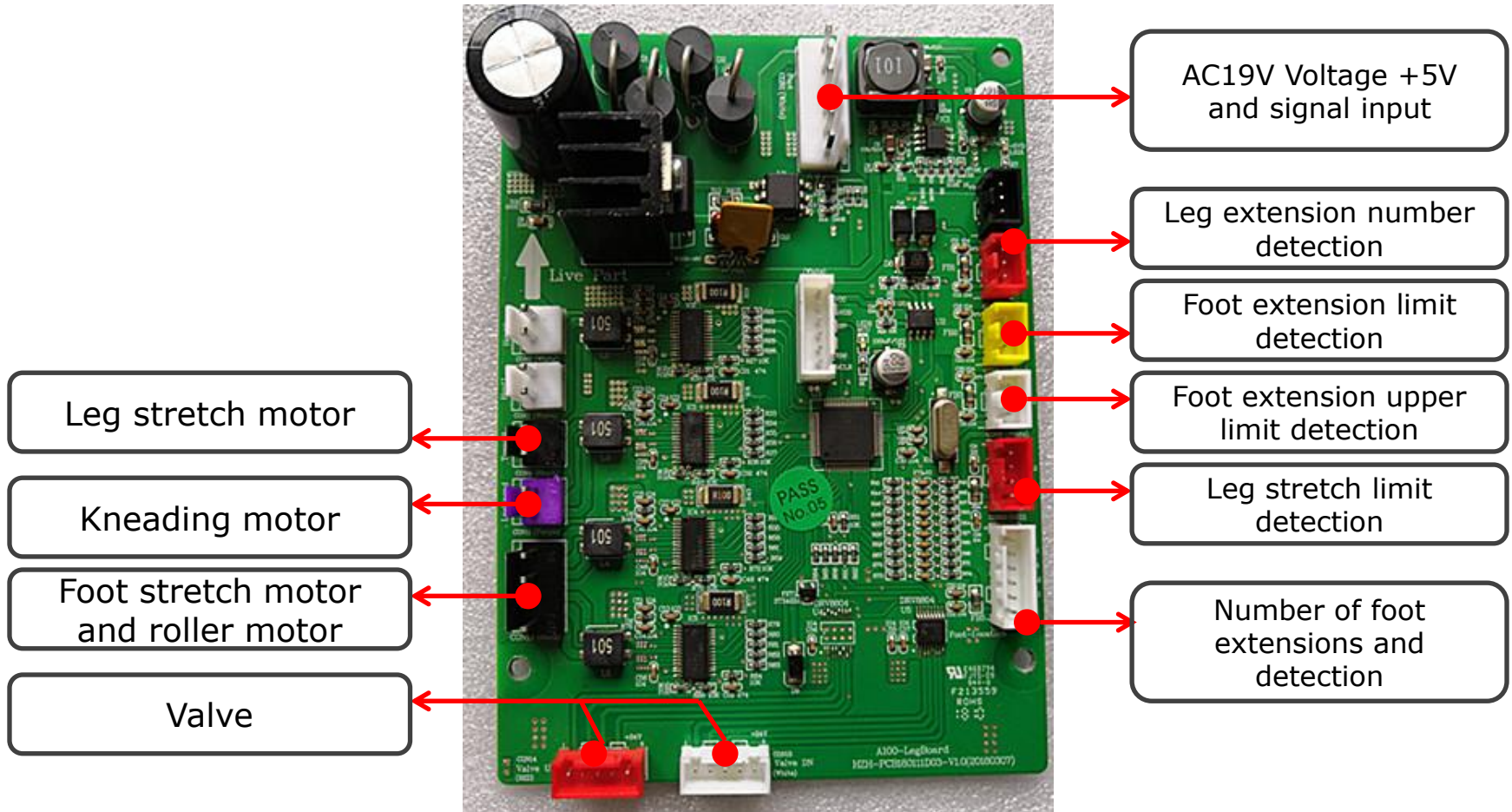

## 4.10、 Calf massage assembly structure and disassembly

### 4.10.4 Adapter board diagram & detection board recognition

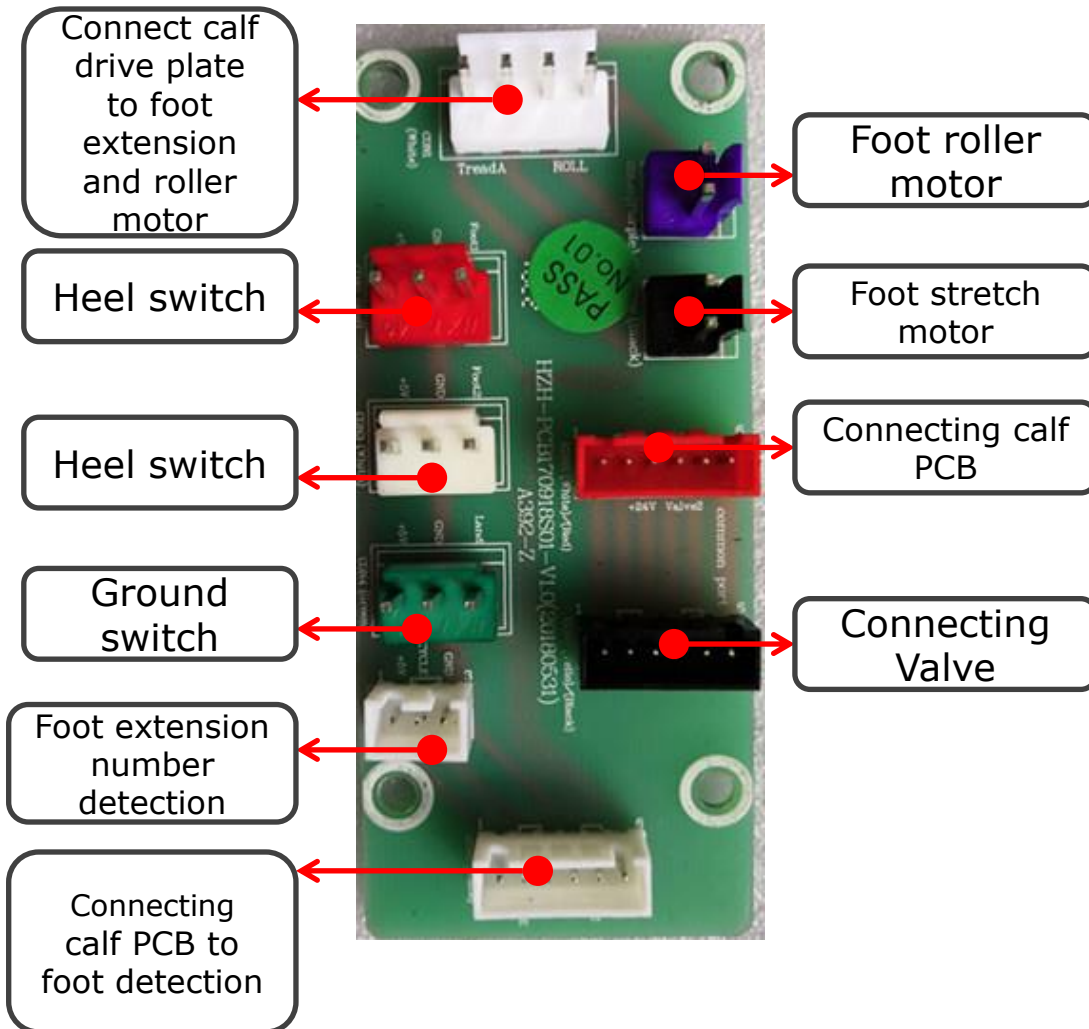

Foot limit detection board

Foot circle number detection board

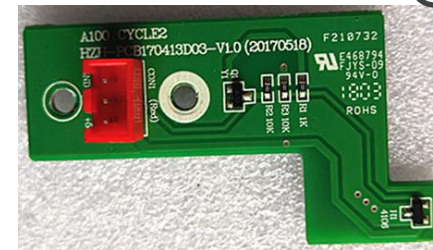

Leg extension number detection board

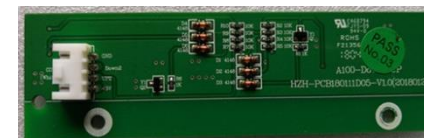

Leg limit detection board

## 4.10、 Calf massage assembly structure and disassembly

### 4.10.5 Replace calf PCB schematic



A、 Remove 4 fixing screws of PCB cover first.



B、 Then remove fixing screws and plug wires of PCB.

## 4.10、 Calf massage assembly structure and disassembly

### 4.10.6 Schematic & video of removing calf and fixing rear cover



A、 Remove the red dot on back first.



B、 Then remove the bottom labeling screw.

( **Back cover removal video** ) 

## 4.10、 Calf massage assembly structure and disassembly

### 4.10.7 Schematic & video of removing leg stretch motor

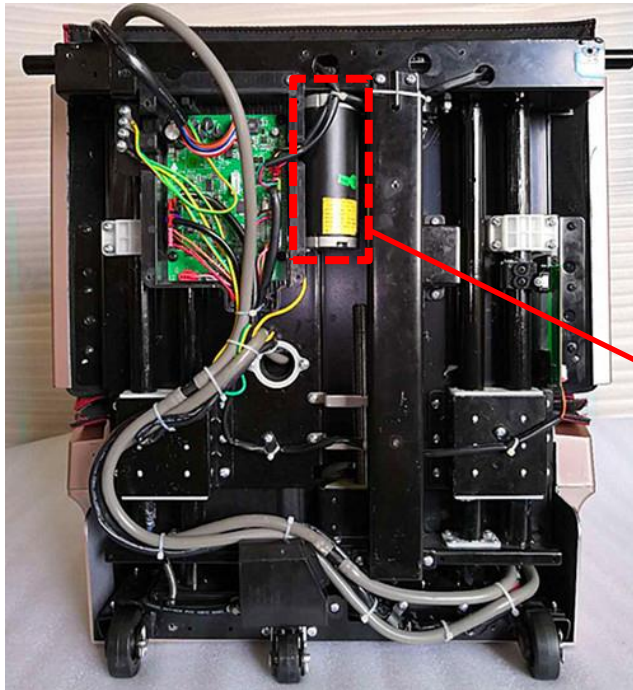

A、 Remove back cover first.

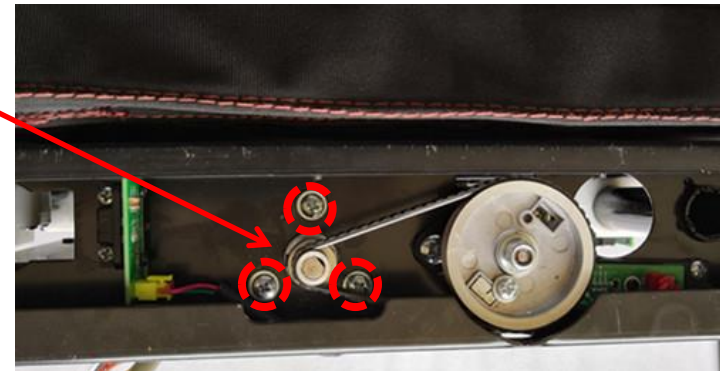

B、 Remove belt and motor fixing screws

**( Leg stretch motor disassembly video )**



## 4.10、 Calf massage assembly structure and disassembly

### 4.10.8 Schematic & video of removing kneading motor

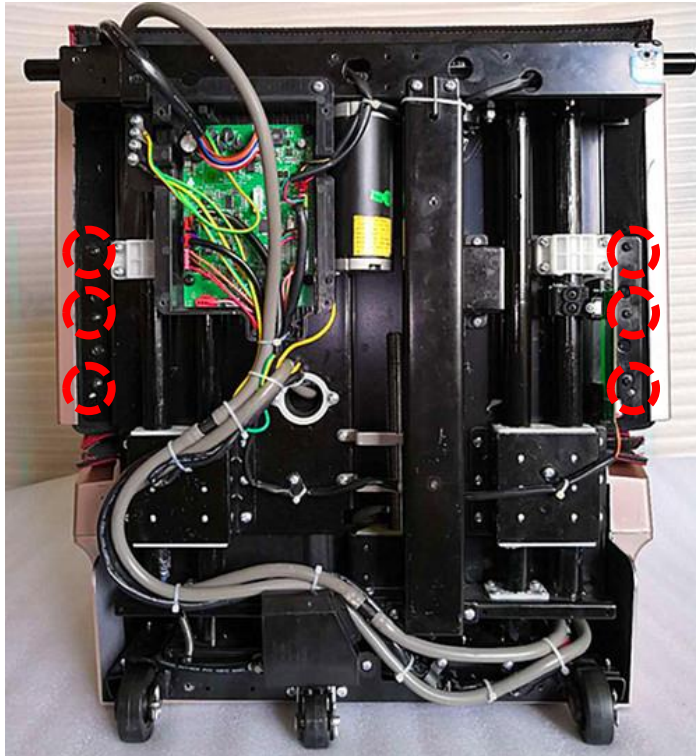

A、 Remove 6 screws in figure to separate footrest from main body first.



B、 Then remove left and right side decorative panels and leather cover

## 4.10、 Calf massage assembly structure and disassembly

### 4.10.8 Schematic & video of removing kneading motor



A、 Remove 5 screws on side marked in figure, total 10 screws

B、 Remove cover on both sides

## 4.10、 Calf massage assembly structure and disassembly

### 4.10.8 Schematic & video of removing kneading motor

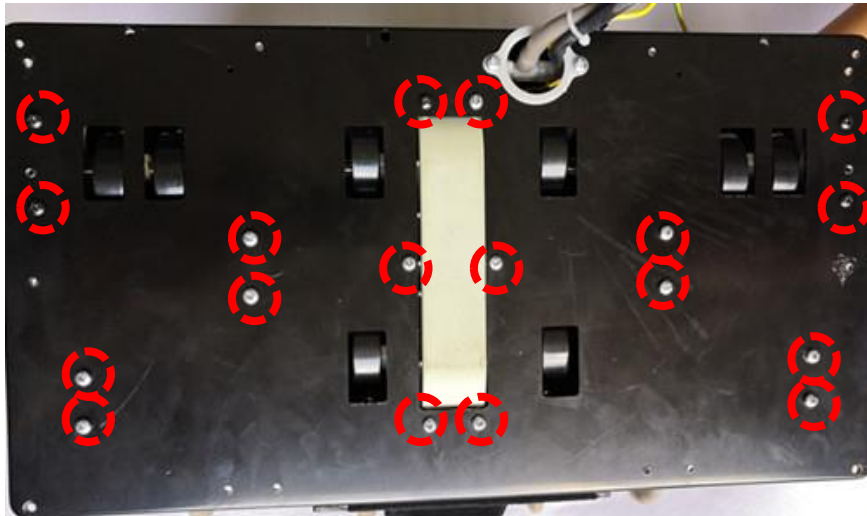

A、 Remove the fixing screws on the metal board

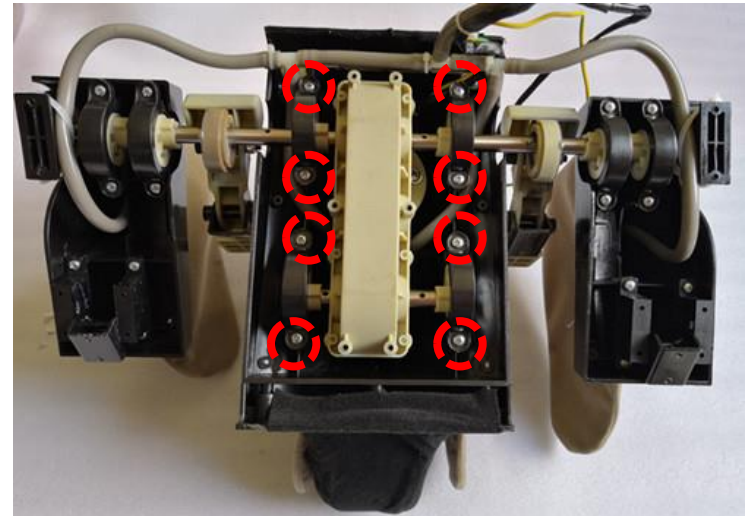

B、 Remove the 8 screws on gearbox bearing

## 4.10、 Calf massage assembly structure and disassembly

### 4.10.8 Schematic & video of removing kneading motor

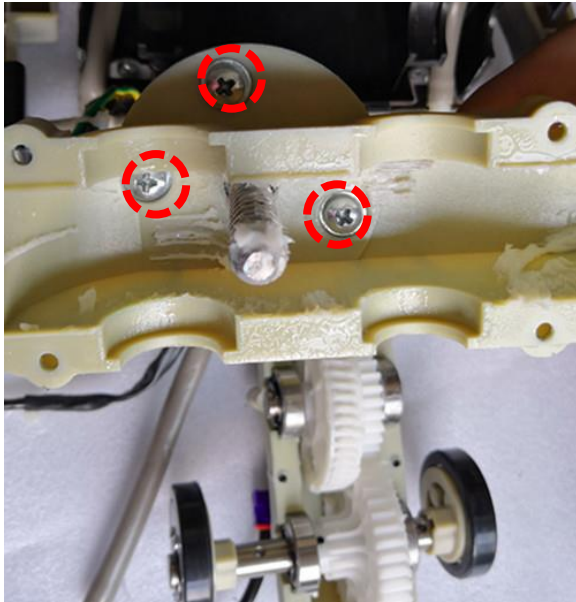

A、 Then remove fixing screws on the upper and lower covers of gearbox and kneading motor.

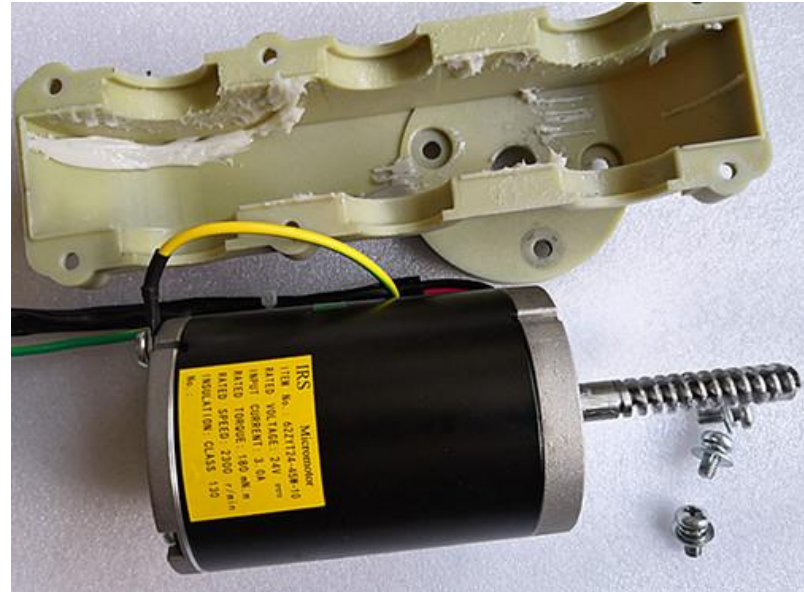

B、 Replace kneading motor and gearbox

**( Kneading motor disassembly video )**



## 4.10、 Calf massage assembly structure and disassembly

### 4.10.9 Schematic & video of removing foot stretch motor & roller motor

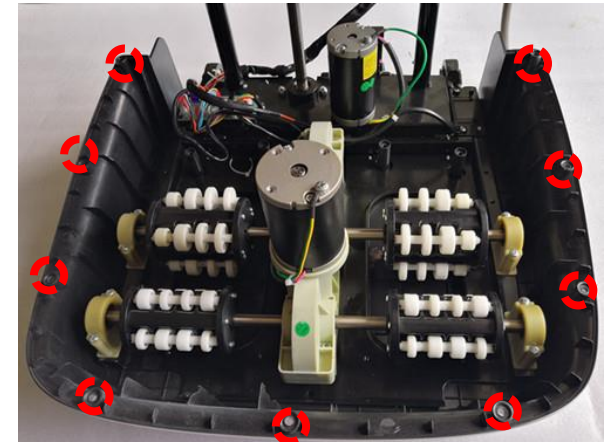
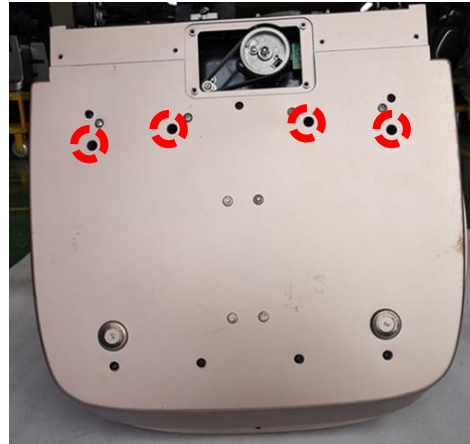

A、 First remove back cover of lower leg, then remove 9 screws on top cover of foot and 4 screws at bottom cover

B、 Separate wire and air hose

## 4.10、 Calf massage assembly structure and disassembly

### 4.10.9 Schematic & video of removing foot stretch motor & roller motor

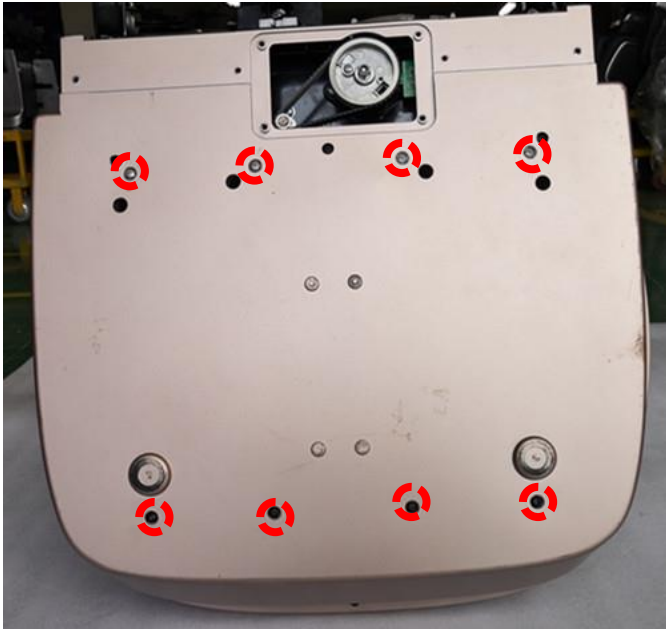

A、 Remove 8 fixing screws of bottom cover

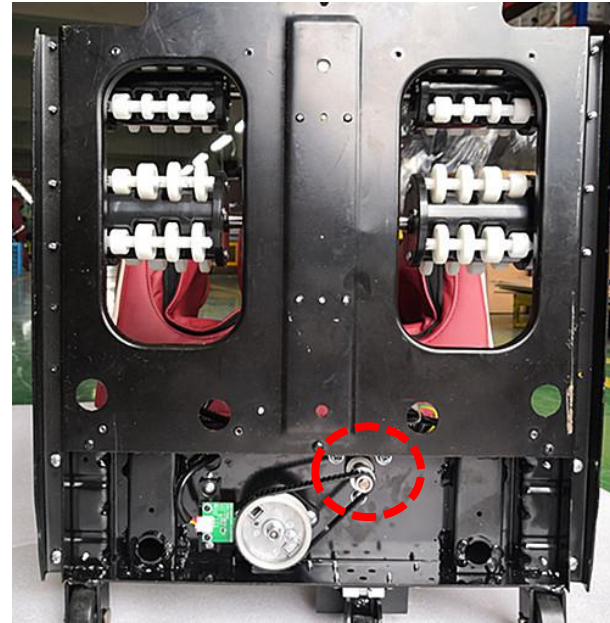

B、 After removing 3 screws fixed of motor, stretch motor can be replaced.

## 4.10、 Calf massage assembly structure and disassembly

### 4.10.9 Schematic & video of removing foot stretch motor & roller motor

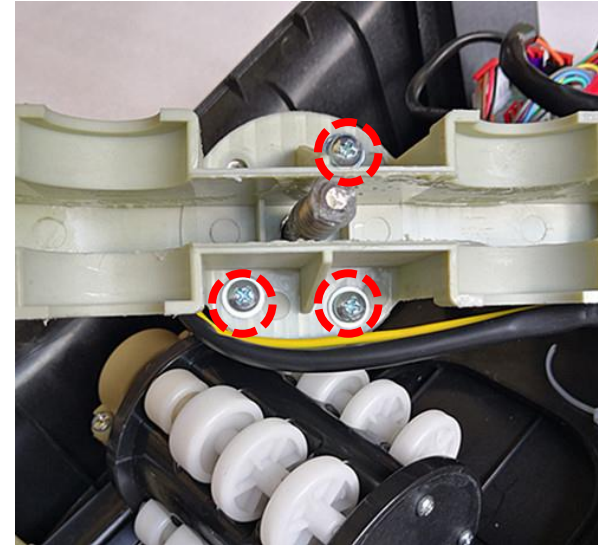
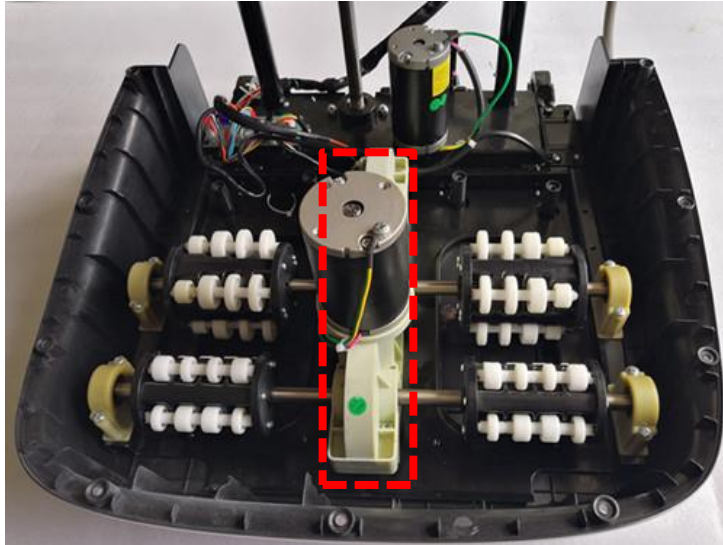

A、 Remove 6 screws of roller gearbox

B、 3 screws of roller motor can be replaced.

**( Foot stretch motor & roller motor disassembly video )**



## 4.10、 Calf massage assembly structure and disassembly

### 4.10.9 Schematic & video of removing foot stretch motor & roller motor

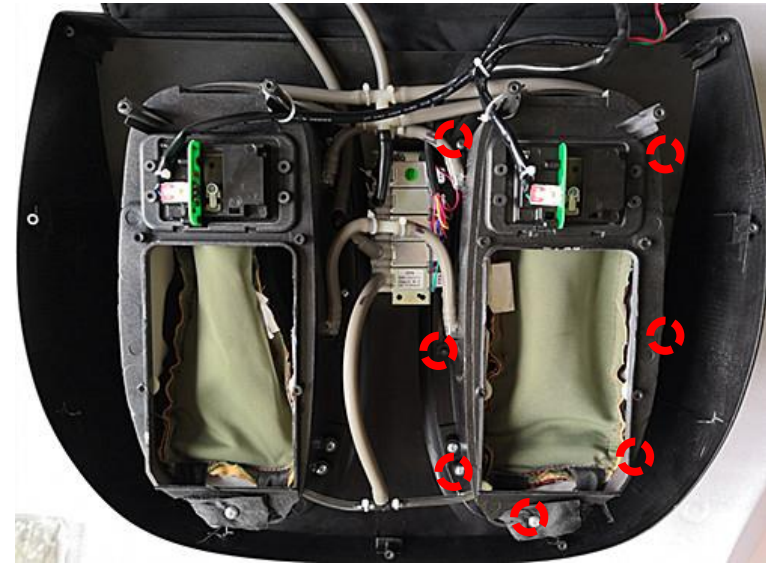

A、 Remove embossing strip on the basis of previous disassembly

## 4.10、 Calf massage assembly structure and disassembly

### 4.10.10 Schematic & video of removing foot kneading cloth



B、 Then remove fixing screws of kneading cloth cover and detach the Velcro.

**( Foot kneading cloth disassembly video )**



# **Massage chair Trouble shooting and maintenance**

- 1, Controller error code reason
- 2, the use of digital multi-meter
- 3, the whole machine does not work
- 4, kneading does not work
- 5, tapping does not work
- 6, the finger pressure motor does not work
- 7, the calf has no function
- 8, the massage hand can not walk up and down
- 9, kneading motor does not work
- 10, the backrest or calf can not up and down
- 11, negative oxygen ions does not work
- 12, Bluetooth music does not work
- 13, a group of air pressure does not work
- 14, the armrest LED light not work
- 15, back heating does not work



**1, the controller error code**

| <b>Display</b> | <b>Error</b>  | <b>Possible reason</b>   | <b>Troubleshooting</b>   |
|----------------|---|--|--|
| <b>E0</b>      | The lower limit switch on the massage hand is detected at the same time   | 1. The upper and lower limit switch lines are not connected well.<br>2. The upper and lower limit switches are damaged (one or two).   | Software closes up and down moving motor                       |
| <b>E1</b>      | No position signal of up and down walking circle detected in unit time  | 1.The upper and lower position signal lines are not connected.<br>2.The walking detection code wheel collides and detects the photoelectric pair tube.<br>3.Moving motor is broken.<br>4.The moving motor drive circuit has problem.<br>5.Overload or other reasons make the up and down moving motor not work properly. | Software closes up and down moving motor                       |
| <b>E2</b>      | During the up or down process of the massage hand, the upper limit or lower limit signal is not detected within the specified time. | 1.Overload or other causes the moving speed of the up and down moving motor to become very slow.<br>2.The upper and lower limit switches are damaged.  | Software closes up and down moving motor and cut off the power |
| <b>E3</b>      | Kneading width is not detected  | 1. Kneading width detection photoelectric damage to the tube (one or two)<br>2. The kneading motor is broken.<br>3. Kneading drive circuit has problem.<br>4. Overload or other reasons make the motor not working properly  |  |

## 1, the controller error code

| Display   | Error  | Possible reason  | Troubleshooting                     |
|-----------|--|--|-------------------------------------|
| <b>E4</b> | The number of lap lift motor laps per unit time is not detected  | <ol style="list-style-type: none"> <li>1. The lap detection Hall is damaged.</li> <li>2. Motor broken.</li> <li>3. Motor drive circuit has problem.</li> <li>4. The load is too heavy or other causes the motor to not work properly.</li> </ol> | Software closes the calf lift motor |
| <b>E5</b> | The number of laps of the backrest lift motor is not detected per unit time  | <ol style="list-style-type: none"> <li>1. The lap detection Hall is damaged.</li> <li>2. Motor broken.</li> <li>3. Motor drive circuit has problem.</li> <li>4. Overload or other causes the motor not to work properly.</li> </ol>              | Software closes the back lift motor |
| <b>E6</b> | The lower leg lift motor limit switch detects the limit at the same time   | <ol style="list-style-type: none"> <li>1. The upper and lower limit switch wires are not connected well.</li> <li>2. The upper and lower limit switches are damaged (one or two).</li> </ol>   | Software closes the back lift motor |
| <b>E7</b> | When the backrest lift motor is walking, the upper and lower limit signals are detected at the same time.                    | <ol style="list-style-type: none"> <li>1. The upper and lower limit switch wires are not connected well.</li> <li>2. The upper and lower limit switches are damaged (one or two).</li> </ol>   | Software closes the back lift motor |
| <b>E8</b> | In the operation of the calf lifting motor, the upper limit or lower limit signal is not detected within the specified time. | <ol style="list-style-type: none"> <li>1. Overload or other reasons make the motor run very slowly.</li> <li>2. The upper and lower limit switches are damaged.</li> </ol>   | Software closes the back lift motor |

## 1, the controller error code

| Display   | Error   | Possible reason  | Troubleshooting                     |
|-----------|---|--|-------------------------------------|
| <b>E9</b> | During the operation of the backrest lift motor, the upper limit or lower limit signal is not detected within the specified time. | <ol style="list-style-type: none"> <li>1. Overload or other reasons make the motor run very slowly.</li> <li>2. The upper and lower limit switches are damaged.</li> </ol>   | Software closes the back lift motor |
| <b>EA</b> | Tapping motor drive circuit detection error   | <ol style="list-style-type: none"> <li>1. Tapping motor drive circuit problem.</li> <li>2. The tapping motor failed, causing the current to be too large.</li> <li>3. If the load is too heavy or other causes the motor is blocked, the current is too large.</li> </ol>    | Software closes tapping motor       |
| <b>EB</b> | Kneading motor drive circuit detection error  | <ol style="list-style-type: none"> <li>1. Kneading motor drive circuit problem.</li> <li>2. The kneading motor malfunctions, causing excessive current.</li> <li>3. If the load is too heavy or other causes the motor is blocked, the current is too large.</li> </ol>      | Software closes kneading motor      |
| <b>EC</b> | Massage hand walking motor drive circuit detection error  | <ol style="list-style-type: none"> <li>1. Walking motor drive circuit problem.</li> <li>2. The travel motor is broken, causing excessive current.</li> <li>3. If the load is too heavy or other causes the motor is blocked, the current is too large.</li> </ol>            | Software closes travel motor        |
| <b>ED</b> | Calf lift motor drive circuit detection error   | <ol style="list-style-type: none"> <li>1. Calf lifting motor drive circuit problem.</li> <li>2. The calf lifting motor is broken, causing excessive current.</li> <li>3. If the load is too heavy or other causes the motor is blocked, the current is too large.</li> </ol> | Software closes the calf lift motor |

## 1, the controller error code

| Display   | Error  | Possible reason  | Troubleshooting          |
|-----------|--|--|--------------------------|
| <b>EE</b> | Backrest lift motor drive circuit detection error  | <ol style="list-style-type: none"> <li>1. Backrest lift motor drive circuit problem.</li> <li>2. The backrest lift motor is broken, causing excessive current.</li> <li>3. If the load is too heavy or other causes the motor is blocked, the current is too large.</li> </ol> | Software close the motor |
| <b>EF</b> | massage hand stretch motor drive circuit detection error   | <ol style="list-style-type: none"> <li>1. Backrest lift motor drive circuit problem.</li> <li>2. The backrest lift motor is broken, causing excessive current.</li> <li>3. If the load is too heavy or other causes the motor is blocked, the current is too large.</li> </ol> | Software close the motor |
| <b>F0</b> | The massage hand stretch motor detects both front and rear limit signals   | <ol style="list-style-type: none"> <li>1. Backrest lift motor drive circuit problem.</li> <li>2. The backrest lift motor is broken, causing excessive current.</li> <li>3. If the load is too heavy or other causes the motor is blocked, the current is too large.</li> </ol> | Software close the motor |
| <b>F1</b> | In the operation of the stretch motor of the massage hand, the position signal of the walking circle is not detected within the specified range. | <ol style="list-style-type: none"> <li>1. Backrest lift motor drive circuit problem.</li> <li>2. The backrest lift motor is broken, causing excessive current.</li> <li>3. If the load is too heavy or other causes the motor is blocked, the current is too large.</li> </ol> | Software close the motor |

## 1, the controller error code

| Display   | Error   | Possible reason  | Troubleshooting                        |
|-----------|---|--|--|
| <b>F2</b> | In the operation of the stretch motor of the massage hand, the upper limit or lower limit is detected after the specified time. | <ol style="list-style-type: none"> <li>1. Backrest lift motor drive circuit problem.</li> <li>2. The backrest lift motor is broken, causing excessive current.</li> <li>3. If the load is too heavy or other causes the motor is blocked, the current is too large.</li> </ol> | Software close the motor               |
| <b>F3</b> | The unit positioning signal of the tapping motor is not detected within the unit time.  | <ol style="list-style-type: none"> <li>1. The motor is damaged.</li> <li>2. The belt sheave is off.</li> <li>3. The detection board signal is damaged.</li> </ol>  |  |
| <b>A1</b> | Massage chair and calf communication failure  | <ol style="list-style-type: none"> <li>1. Circuit board failure</li> <li>2. The connection between the calf and the massage chair is loose or the harness is broken.</li> </ol>  |  |
| <b>A2</b> | Foot stretch motor limit switch detects the limit at the same time  | <ol style="list-style-type: none"> <li>1. The upper and lower limit switch wires are not connected.</li> <li>2. The upper and lower limit switches are damaged (one or two).</li> </ol>  | Software closes the foot stretch motor |

## 1, the controller error code

| Display   | Error   | Possible reason  | Troubleshooting                             |
|-----------|---|--|---|
| <b>A3</b> | In the work of the foot stretch motor, the upper limit or lower is not detected within the specified time.<br>Limit signal. | <ol style="list-style-type: none"> <li>1. Overload or other reasons make the motor run very slowly.</li> <li>2. The upper and lower limit switches are damaged.</li> </ol>   | Software closes the foot stretch motor      |
| <b>A4</b> | The number of stretch motor laps in the unit can not be detected in unit time   | <ol style="list-style-type: none"> <li>1. The lap detection Hall is damaged.</li> <li>2. Motor failure.</li> <li>3. Motor drive circuit problem.</li> <li>4. The load is too heavy or other causes the motor to not work properly.</li> </ol>                                | Software closes the foot stretch lift motor |
| <b>A5</b> | Foot roller motor drive circuit detection error   | <ol style="list-style-type: none"> <li>1. Foot roller motor drive circuit problem.</li> <li>2. The foot roller motor is broken, causing excessive current.</li> <li>3. If the load is too heavy or other causes the motor is blocked, the current is too large.</li> </ol>   | Software closes the foot roller motor       |
| <b>A6</b> | Foot stretch motor drive circuit detection error  | <ol style="list-style-type: none"> <li>1. Foot stretch motor drive circuit problem.</li> <li>2. The foot stretch motor is broken, causing excessive current.</li> <li>3. If the load is too heavy or other causes the motor is blocked, the current is too large.</li> </ol> | Software closes the foot stretch motor      |

## 1, the controller error code

| Display   | Error  | Possible reason   | Troubleshooting                            |
|-----------|--|---|--|
| <b>A7</b> | Leg stretch motor limit switches detects the limit at the same time                        | <ol style="list-style-type: none"> <li>1. The upper and lower limit switch wires are not connected well.</li> <li>2. The upper and lower limit switches are damaged (one or two).</li> </ol>  | Software closes the leg stretch motor      |
| <b>A8</b> | The leg stretch motor didn't detected up and lower limit signal within the specified time. | <ol style="list-style-type: none"> <li>1. Overload or other reasons make the motor run very slowly.</li> <li>2. The upper and lower limit switches are damaged.</li> </ol>  | Software closes the leg stretch motor      |
| <b>A9</b> | The leg stretch motor didn't detected circles signal in unit time                          | <ol style="list-style-type: none"> <li>1. The circle detection Hall is damaged.</li> <li>2. Motor failure.</li> <li>3. Motor drive circuit problem.</li> <li>4. the load is too heavy or other reasons make the motor not working properly.</li> </ol>                      | Software closes the leg stretch lift motor |
| <b>AA</b> | Leg stretch motor drive circuit detection error  | <ol style="list-style-type: none"> <li>1. leg stretch motor drive circuit problems.</li> <li>2. The leg stretch motor is broken, causing excessive current.</li> <li>3. If the load is too heavy or other causes the motor is blocked, the current is too large.</li> </ol> | Software closes the leg stretch motor      |
| <b>AB</b> | Calf kneading motor drive circuit detection error  | <ol style="list-style-type: none"> <li>1. Foot roller motor drive circuit problem.</li> <li>2. The foot roller motor is broken, causing excessive current.</li> <li>3. If the load is too heavy or other causes the motor is blocked, the current is too large.</li> </ol>  |  |

## 1, the controller error code

| Display | Error                    | Possible reason   | Troubleshooting |
|---------|--------------------------|---|-----------------|
| 01      | Calf touch ground switch | <ol style="list-style-type: none"><li>1. The grounding Hall switch is damaged.</li><li>2. The metal pin on the grounding switch is bended.</li><li>3. Whether there are other items on the ground covered the calf, then touch ground switch can't receive the signal.</li><li>4. After the magnet enables the Hall signal to be valid, after the switch detects the spring reset, the magnet still enables the Hall signal because the reset distance is not enough.</li></ol> |                 |
| 02      | Right heel signal        |   |                 |
| 03      | Left heel signal         |   |                 |

## 2、 multi-meters

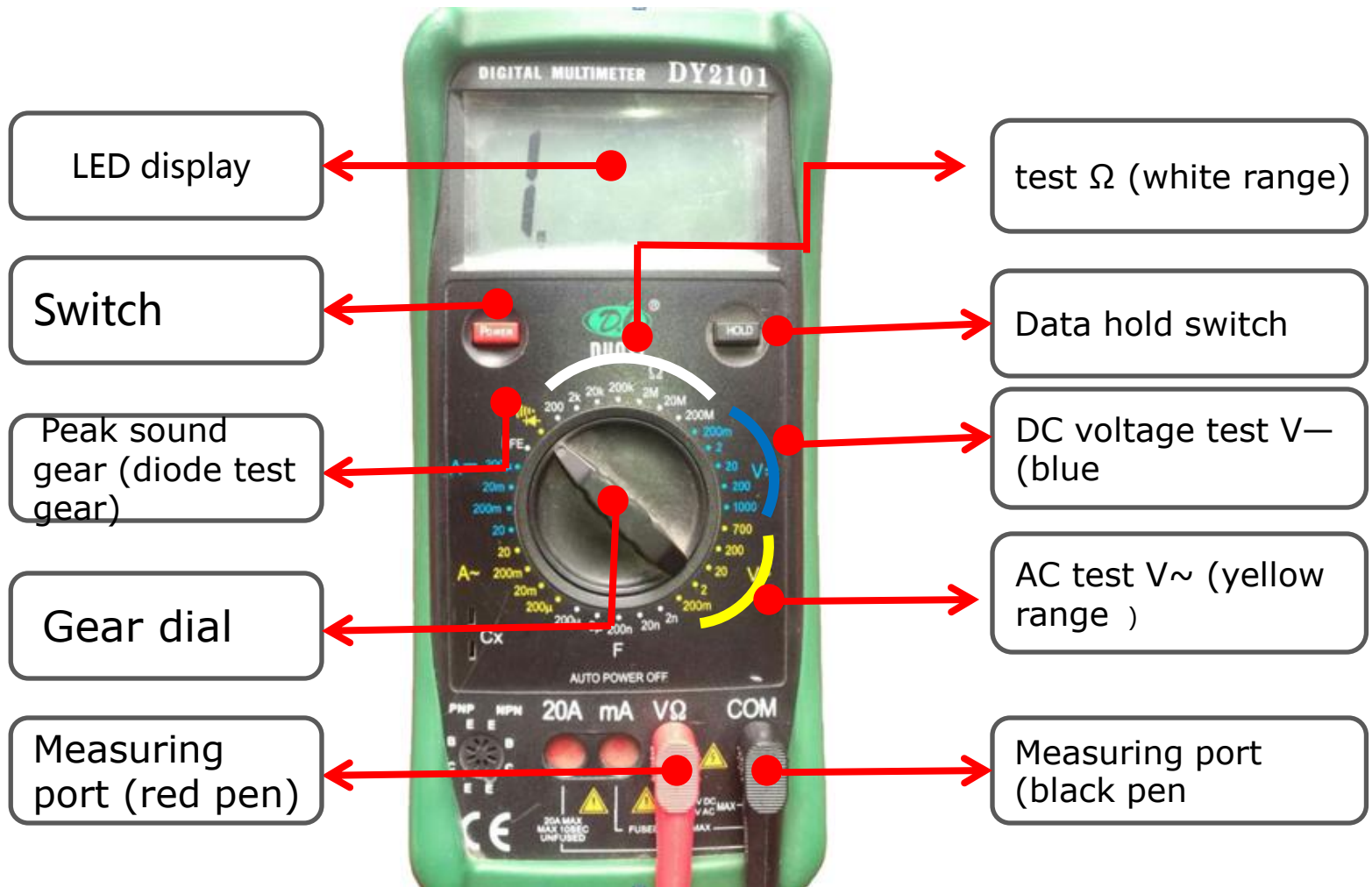

## 2.1, different function test

Power switch: The on/off of the digital multimeter power supply.

Data hold switch: make a record of the tested data, for comparison.

Beep: measuring diode, the circuits, the alarm function.

Resistance: measure the resistance of the resistor.

DC voltage: measure DC voltage.

AC voltage: measure AC voltage.

V $\Omega$  / COM: Red end (+ pole) for V $\Omega$  test, black end (- pole) for COM test

**Note:** Please choose the appropriate measuring range once you need to test resistance or voltage. If the range is too small, it can't be measured. If the range is too big, the error range will be big.

If you don't know the voltage level you want to test, advise you choose a larger measuring range.

## 2.2. Measurement of line on/off



**Open circuit**

As shown on the left, first turn the multimeter to the beep and turn on its power switch. At this time, the multimeter displays "1."; then the two gauges are distributed to the metal ends of the red wires in the figure. The multimeter still shows "1." There is no change, indicating that there is an open circuit in the middle of the wire, that is, the line is blocked.

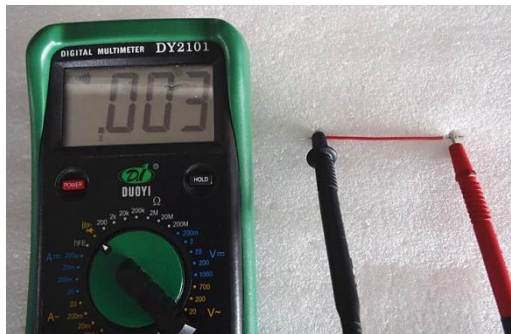

**Conduction**

As shown on the left, the same method as the above test, such as the multimeter displays ".003" or ".00N" number and sounds an alarm, indicating that the wire is conductive.

## 2.3, measurement of the motor

|                          |   |  |   |
|--------------------------|---|--|---|
| <p>Motor measurement</p> |  |  | <p>As shown in the figure on the left, it shows "1", indicating that the internal coil of the motor has been open.</p>    |
|                          |  |  | <p>As shown on the left, the result is "42.5" <math>\Omega</math>. In the normal resistance range, the motor is good.</p> |

—Other motor coil resistance reference

Air pump AC110V: about 100 $\Omega$  solenoid valve DC12V: 45 $\Omega$

Motor DC110V: 35~80 $\Omega$  Electric cylinder DC110V: 100 ~ 120 $\Omega$

## 2.4, measurement of AC voltage



—As shown in the figure above: measure the home use plug-in power supply (220V), the range is selected as 700, and the test result is displayed as “225”, indicating that the actual voltage of this group of sockets is 225V at this moment (the switch is on, so there is electricity, the light is on).



—As shown in the above figure: Measure our home use plug-in power supply (220V), the range is selected as 700, and the test result is displayed as “000”, indicating that the actual voltage of this group of sockets is 0V at this moment (the switch is not on, so there is no power, the light is also not lit).

## 2.5, DC voltage measurement



- As shown in the figure above: The test result is displayed as "1.58", indicating that the voltage at both ends of the battery is 1.58V, and the red pen is connected to the "+" pole of the battery, and the black pen is connected to the electromagnetic "-" pole. .

---



As shown in the figure above: The test result is displayed as "-1.58", indicating that the voltage at both ends of the battery is 1.58V, and the red pen is connected to the "-" pole of the battery, and the black pen is connected to the electromagnetic "+" pole.

## 2.6, measurement of the stroke switch



The travel switch is widely used in the massage chair detection circuit, such as 3D massage hand stretch limit, upper and lower stroke limit, A08 calf stretch limit, heel switch and foot touch switch detection, etc. it's the same.

The No. 1 contact is "touching shrapnel", the No. 2 port is "COM" common end, the No. 3 port is "NO" normally open contact, and the No. 4 port is "NC" normally closed contact.

Normally closed NO: Normally closed, and then opened.

Normally open NC: Normally disconnected, and moved.

## 2.6.1, measurement of the travel switch

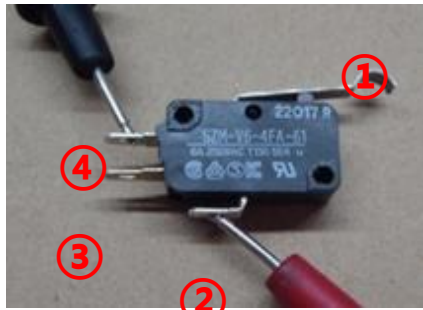

A normally closed group: 1 is not pressed, tested with beep, 2 4 two static contacts are conducting

B normally closed group: 1 when pressed, tested with beep, 2 4 two static contacts are open



A normally open group: 1 when not pressed, tested with beep, 2 3 two static contacts are open

B normally open group: 1 when pressed, test with beep, 2 3 two static contacts are conductive

3, the whole machine does not work



**Figure1**

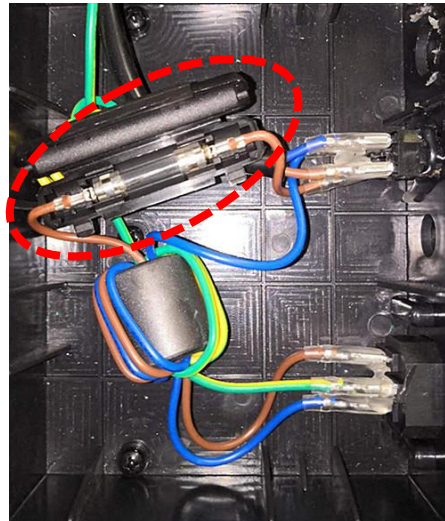

**Figure2**

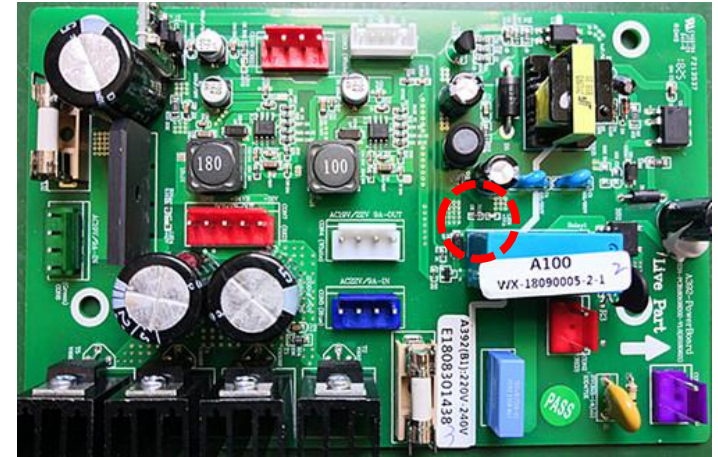

**Figure3**

Fault diagnosis and maintenance:

- A The controller was broken, can not be turned on, replace a new one to test(Figure 1);
- B. The fuse is burned, the external voltage or load causes the short circuit of the PCB, replace the PCB, fuse (Figure 2)
- C. Check if the power board indicator light 5VA is normal (Fig. 3). If it is off, the problem could be caused by the power supply, or the power switch damaged, if the indicator light is on, we can judge the power supply is ok. The problem could be caused by the PCB, replace a new one.

## 4, kneading motor does not work



**Figure1**

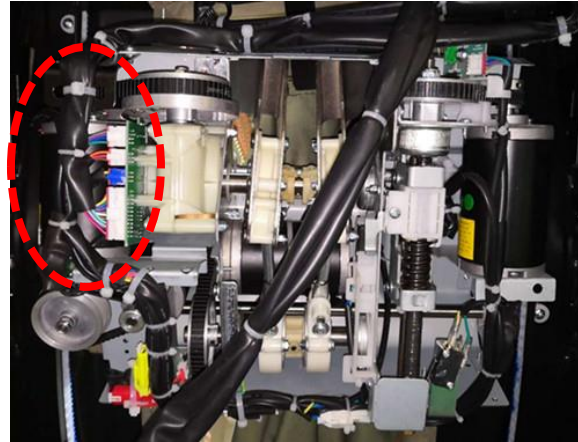

**Figure2**



**Figure3**

Fault diagnosis and maintenance:

A, the role of kneading motor: kneading function, width adjustment

B, Judging method of kneading motor not turning:

1 using the other same voltage to judge whether the motor is good or not.

2 Multi-meter measurement, using the ohmmeter of the multimeter to measure the resistance of the motor, the resistance is about 3  $\Omega$ .

C, when the kneading function does not work, click the S/N position three times in the touch screen, E3 error code display

## 5, the tapping motor does not work

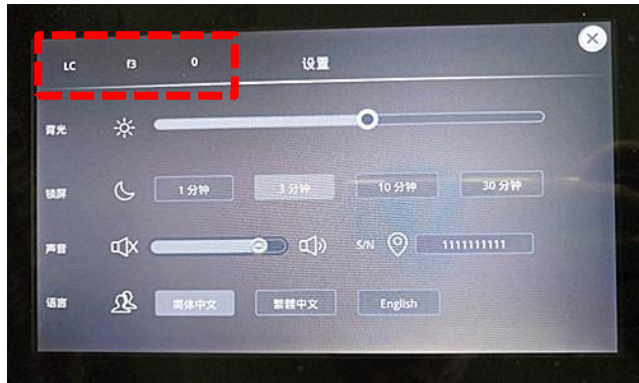

**Figure1**

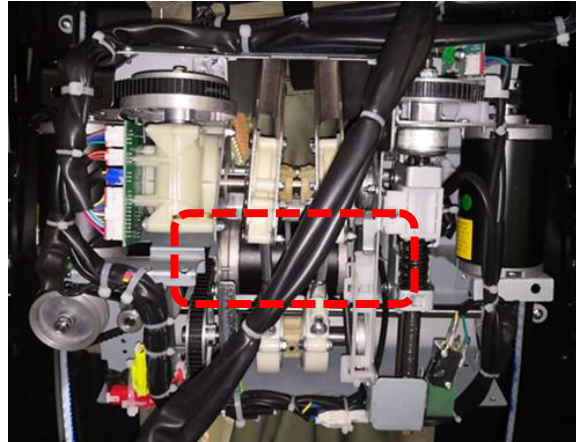

**Figure2**

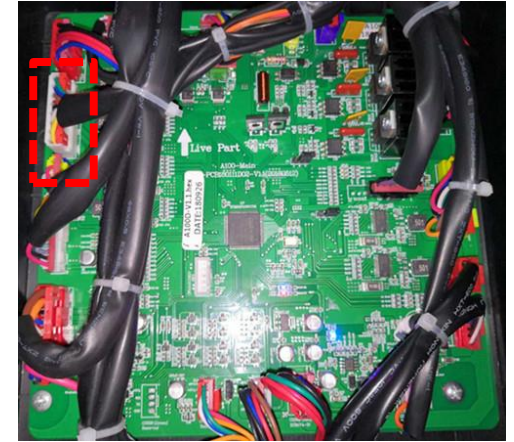

**Figure3**

Fault diagnosis and maintenance:

A, when the fault occurs when the beat motor does not work, press the S/N position continuously in the touch screen setting option.

Three times will display the F3 error code

B, maintenance method: you can use a multimeter to measure the resistance of the motor (about 3  $\Omega$ ), the resistance is normal or not.

If the motor is bad, replace the motor, the resistance is normal, then check if the belt is off, the wires is disconnected, then the PCB problem

## 6, the Shiatsu motor does not work



**Figure1**

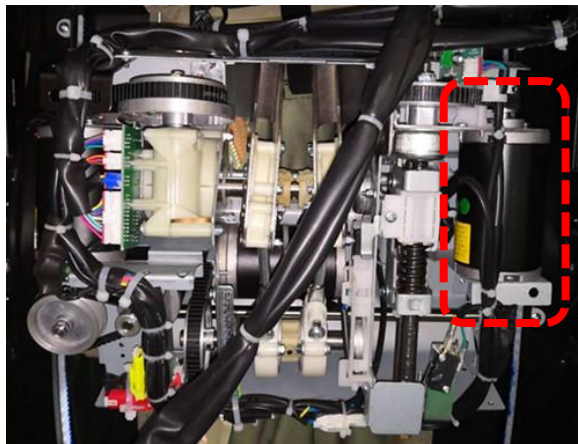

**Figure2**

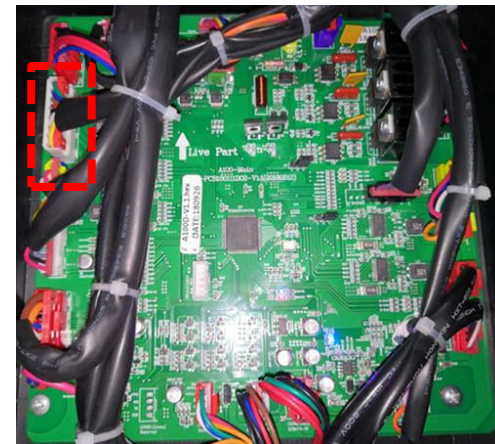

**Figure3**

Fault diagnosis and maintenance:

A, when the fault occurs on the finger pressure motor does not work, press the S/N position three times in the touch screen setting option, will display F1/F2 error code

B, maintenance method: you can use a multimeter to measure the resistance of the motor (about 3  $\Omega$ ), the resistance is normal or not.

If the motor is broken, replace the motor, the resistance is normal, check the circle testing board, the belt is off, and the harness is disconnected or not.

Finally replace the PCB.

7, the calf has no function



**Figure1**

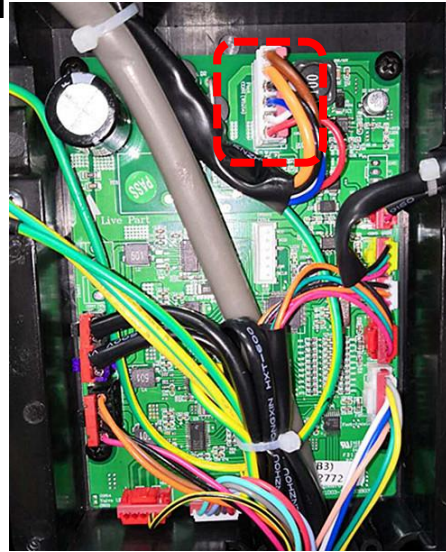

**Figure2**

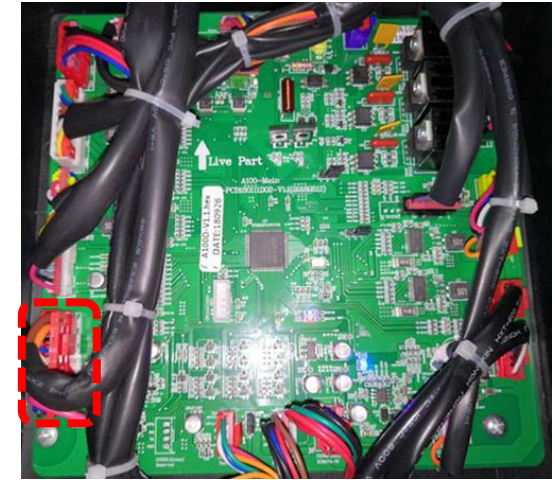

**Figure3**

Fault diagnosis and maintenance:

A, If there is no function on the whole calf, please press S/N continuously in the touch screen setting option three times, the a1 error code will display, indicating that the main and the calf communication signal are disconnected.

B, Trouble shooting: first check whether the corresponding connector of the calf PCB and the main PCB is in good contact, the connection wires are good or not. If they are good, then test leg PCB voltage (AC19V,+5V) marked out in Figure 2, if the voltage is normal, replace the calf PCB, if the voltage is abnormal, check the main PCB and Power Board.

## 8, the Massage hand can not walk up and down



**Figure1**

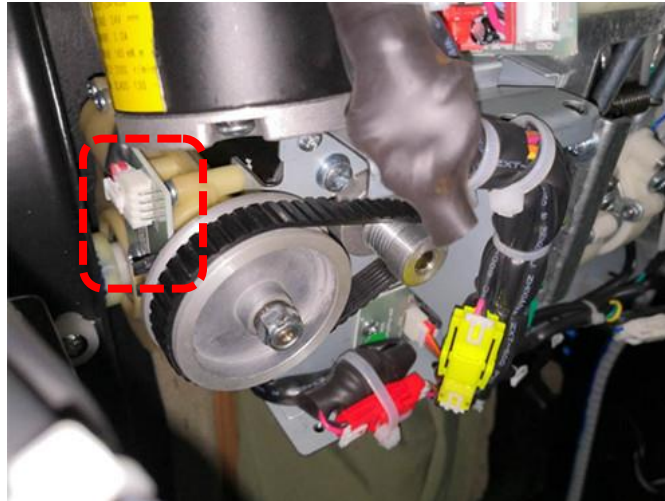

**Figure2**

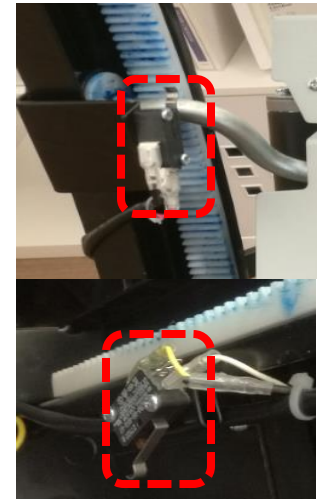
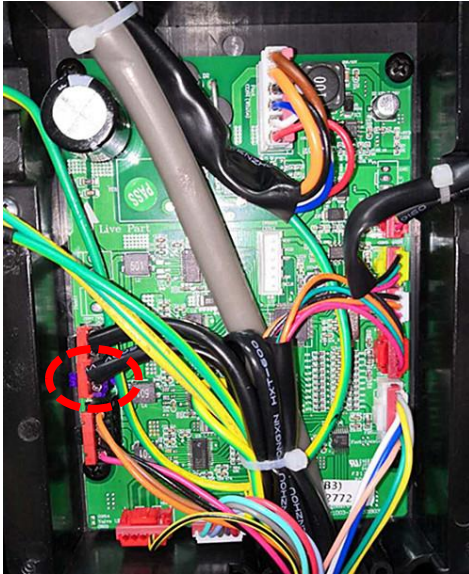

**Figure3**

Fault diagnosis and maintenance:

- A. First check if the back harness is in poor contact or the plug-in is off;
- B. Check whether the motor or the gear box is damaged. You can use the kneading motor power supply to judge whether the motor is good or not.
- C. Check if the moving testing board is damaged;
- D. Check whether the upper and lower limit switches are damaged;
- E. Replace way to check whether the PCB is damaged;

## 9, Kneading motor does not work



**Figure1**

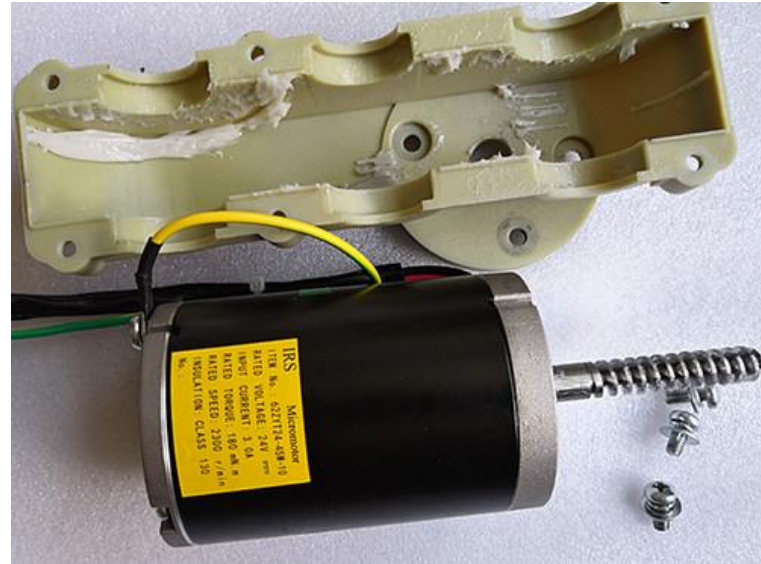

**Figure2**

Fault diagnosis and maintenance:

A, first find the kneading motor plug on the calf PCB, as shown in Figure 1 purple plug, no power detection kneading motor

Resistance value, the multimeter ohm measured at about 5  $\Omega$ , if there is no resistance, replace the kneading motor, if it is ok, then check the calf PCB.

B, Through the calf PCB can measure if there is 24V voltage out put in the kneading motor plug, or replace the PCB by the replacement way.

10, the backrest or calf can not be raise up and down

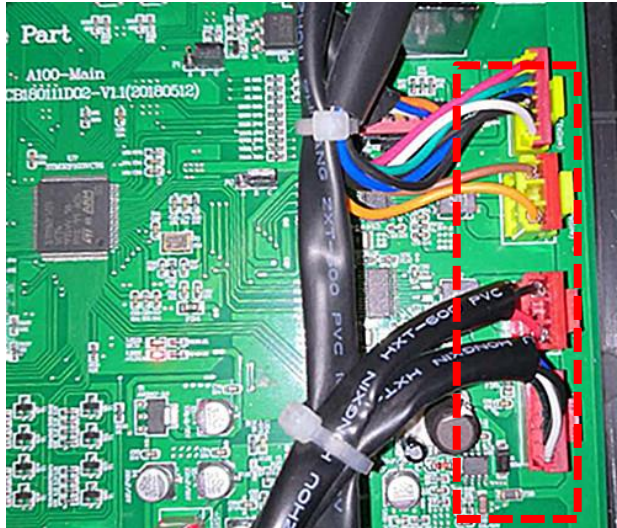

**PCB**



**backrest lifting motor**

Fault diagnosis and maintenance:

A, replacement way : When the backrest can not be lifted, insert the plug of the backrest lifting motor into the calf lifting motor position, adjust the calf up or down in the angle adjustment option, if the backrest lifting motor can rise up and down, we can judge that the backrest lifting motor is good, the problem is on the PCB, replace the PCB, if it can't rise up and down, the problem maybe caused by the lifting motor, replace a new one.

B, use the multi-meter measures the resistance of the lifting motor, the resistance is about 5  $\Omega$ , no resistance or a large difference, then replace the lifting motor. Otherwise, replace the PCB.

## 11, negative oxygen ion does not work

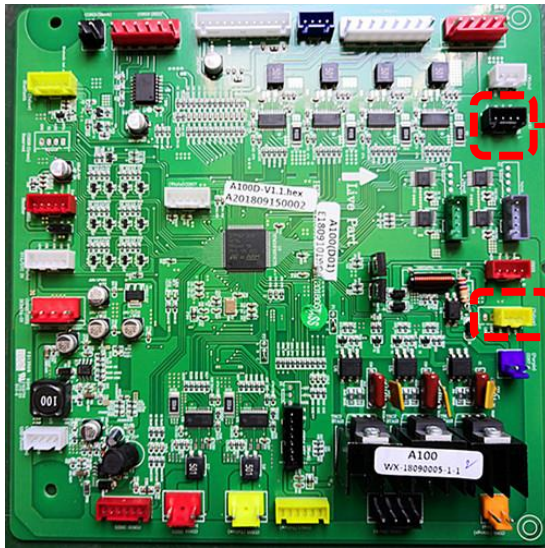

**Figure1**

Fault diagnosis and maintenance:

A. Use a multimeter to measure whether the PCB plug, fan and ion generator foot have DC12V voltage, if don't have voltage, we can judge the PCB is broken, replace PCB; (Fig. 1) (please make sure the negative oxygen ion is on)

B. Check whether the left and right armrest connection plugs are inserted well, and whether the pins are in good sate.

C. Check if the fan and ion generator are damaged then replace it; (Figure 2, Figure 3)

Left and right fans  
and negative  
oxygen ion  
interface

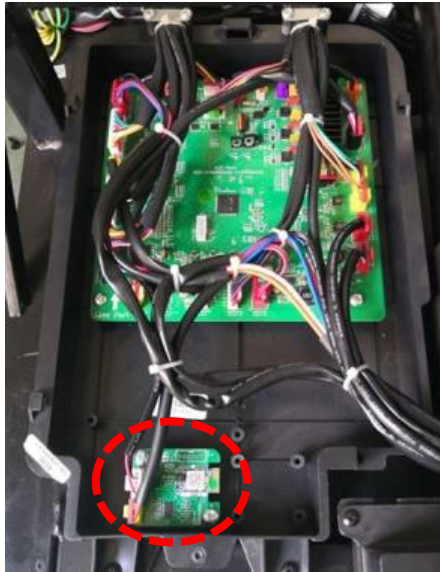

**Figure2**

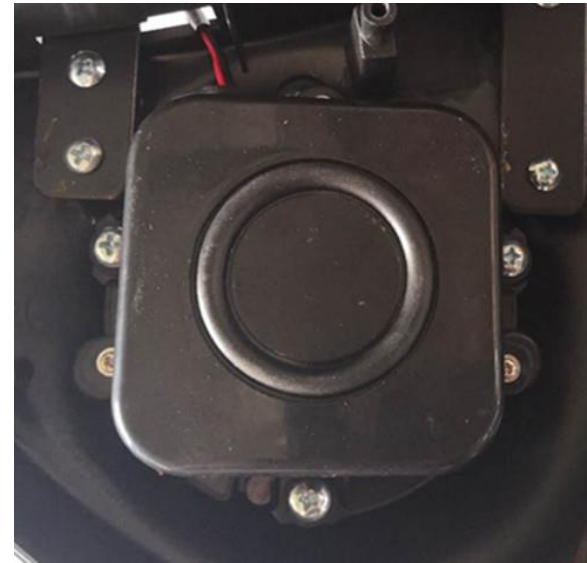

**Figure3**

## 12, Bluetooth music does not work



**Figure1**



**Figure2**

Fault diagnosis and maintenance:

A. (make sure your mobile phone is successfully paired with the chair's Bluetooth) Check if the audio Bluetooth board harness is in good contact or the audio Bluetooth board is broken. Replace it; (Figure 1)

B. Check if the Bluetooth board to the speaker cable is in poor contact;

C, there is no music on one side, check the wiring harness and replace the speaker; (Figure 2)

13, a group of air pressure does not work

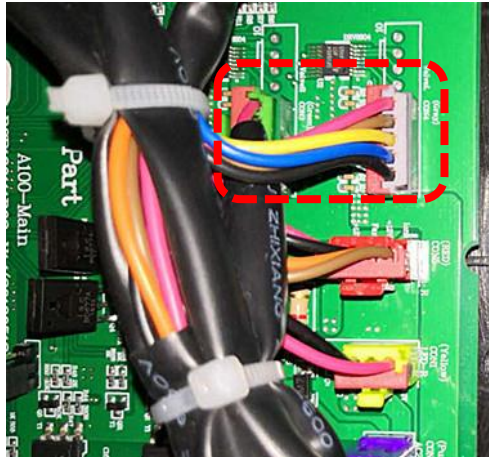

**Figure1**



**Figure2**

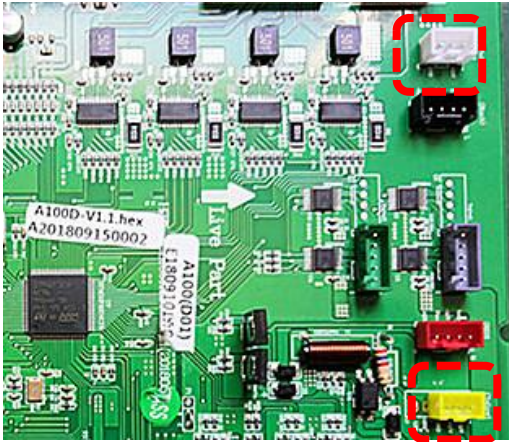

**Figure3**

Fault diagnosis and maintenance:

- A. Check if the air bag is broken or the air hose was bended (Fig. 2, Fig. 3)
- B. The solenoid valve that controls the air pressure is damaged (Fig. 2);
- C. The circuit damaged, replace the PCB.

## 14, armrest LED mood lights do not work



**Figure1**

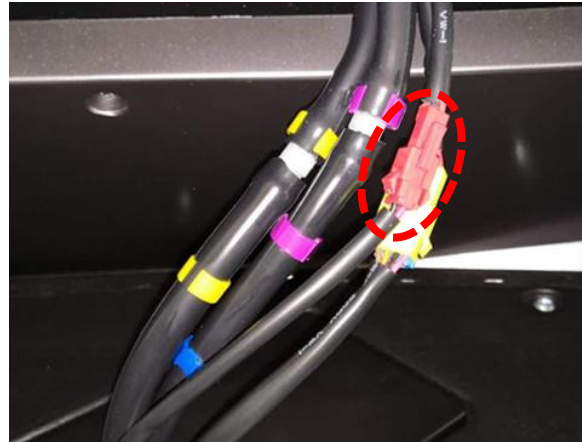

**Figure2**



**Figure3**

Fault diagnosis and maintenance:

- A. Use a multimeter to measure whether the PCB plug-in CON1/CON2 has DC12V voltage, and check the power board for output DC12V; (Figure 1)
- B. Check if the armrest plug is in poor contact or falling off (Figure 2);
- C, the light strip is broken, replace the armrest light board; (Figure 3)

## 15, backrest heating does not work



**Figure1**

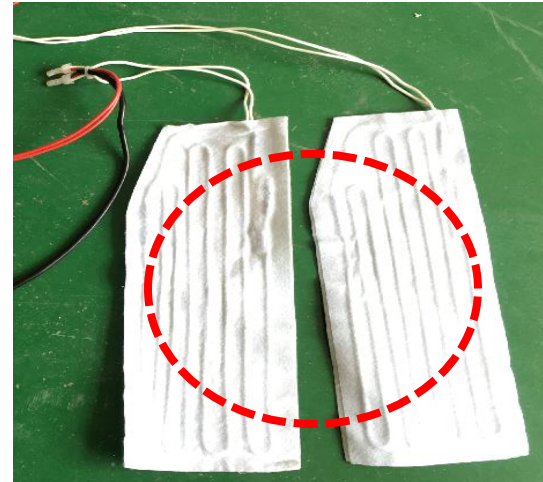

**Figure2**

Fault diagnosis and maintenance:

- A. Check if the backrest heating strip insert plug not connect well or fall out (Fig. 1);
- B. Use a multimeter to measure whether the PCB plug-in CON9 has AC22V voltage, if no voltage, then problem could be caused by PCB, change a new PCB;
- C. Use a multimeter to measure whether the backrest heating strip has resistance value, if don't have, we can replace a new heating strip.